

REVISIONS			
LTR	DESCRIPTION	DATE	APPROVED
B	REDRAWN AND UPDATED	12-9-96	D.N.

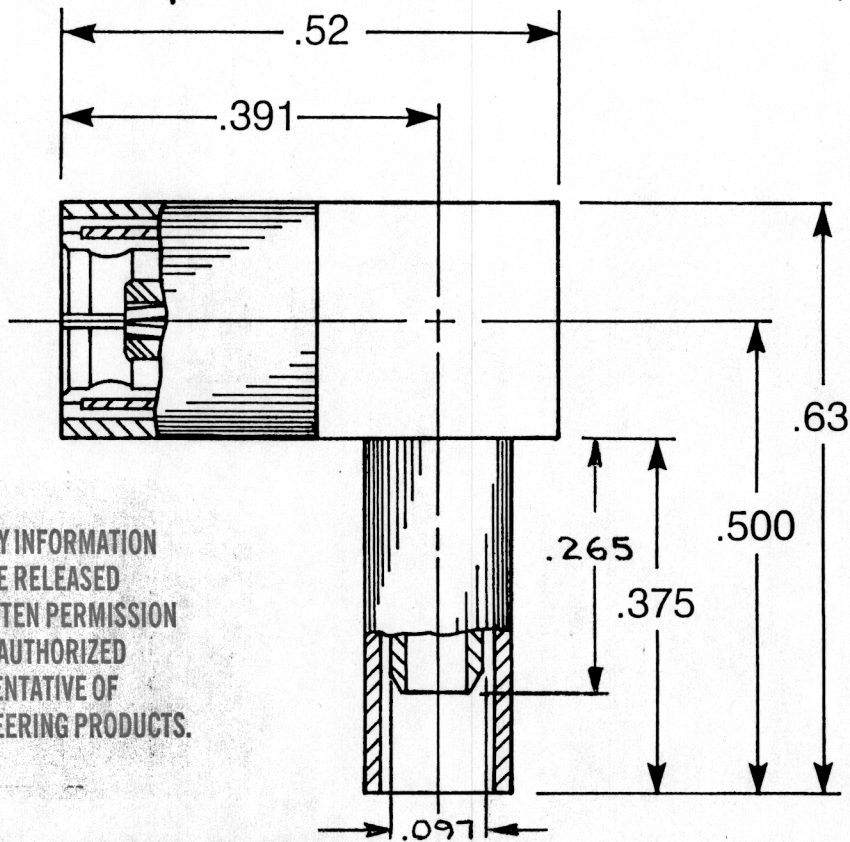

PROPRIETARY INFORMATION  
NOT TO BE RELEASED  
WITHOUT WRITTEN PERMISSION  
FROM AN AUTHORIZED  
REPRESENTATIVE OF  
APPLIED ENGINEERING PRODUCTS.

**NOTES: CONFORMS TO MIL-PRF-39012 SMB SERIES**

**MATERIAL:**

1. INSULATORS = TEFLON, VIRGIN WHITE PER ASTM D1710, GRADE I, TYPE I, CLASS A.
2. CONTACT & SPRING = BERYLLIUM COPPER PER ASTM B196, ALLOY C17300, TEMPER TD04.
3. CRIMP SLEEVE = SEAMLESS COPPER TUBE PER ASTM B75, TYPE C12000, TEMPER: LIGHT ANNEAL O50.
4. ALL OTHER METAL PARTS = BRASS PER ASTM B16, ALLOY C36000, TEMPER H02.

**FINISHES:**

1. CONTACT = GOLD PLATE PER MIL-G-45204, TYPE II, CLASS 1, GRADE C, OVER .00010 TO .00020 STRESS FREE SULFAMATE NICKEL PER QQ-N-290.
2. ALL OTHER METAL PARTS = GOLD PLATE PER MIL-G-45204, TYPE II, CLASS 0, GRADE C OVER .00010 TO .00020 COPPER STRIKE PER MIL-C-14550.

UNLESS OTHERWISE SPECIFIED DIMENSIONS ARE IN INCHES TOLERANCES ON FRAC. 1/64   DECIMAL   ANGLES ± 2°	DRAWN D.N.	DATE 12-9-96	APPLIED ENGINEERING PRODUCTS 104 John W. Murphy Drive, P.O. Box 510 New Haven, CT 06513	
	CHECKED VPS	DATE 12-9-96		
MATERIAL:  SEE NOTES	APPROVED <i>[Signature]</i>	DATE 12/9/96	SMB RIGHT ANGLE FEMALE CABLE PLUG FOR USE WITH RG-174, 179, 188 & 316 CABLE	
	FINISH:  SEE NOTES			
	SIZE A	CODE IDENT NO. 19505	2105-1521-003	
	SCALE NTS	REV. B	SHEET 1	OF 1

# Mouser Electronics

Authorized Distributor

Click to View Pricing, Inventory, Delivery & Lifecycle Information:

Radial:

[2105-1521-003](#)