

Customer Information Sheet

DRAWING No.: M22-301XX00 SHEET 2 OF 2

IF IN DOUBT - ASK

©

NOT TO SCALE

THIRD ANGLE PROJECTION

ALL DIMENSIONS IN mm

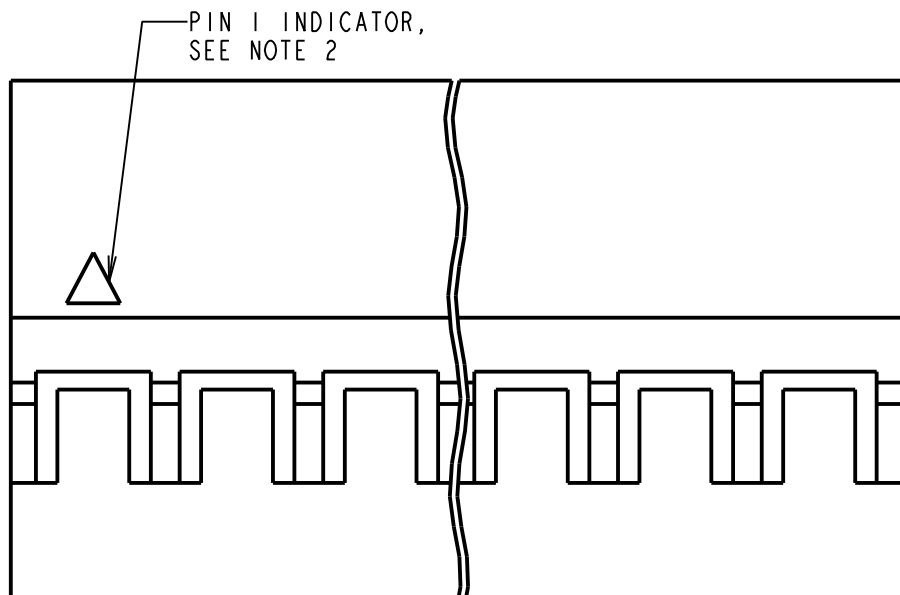
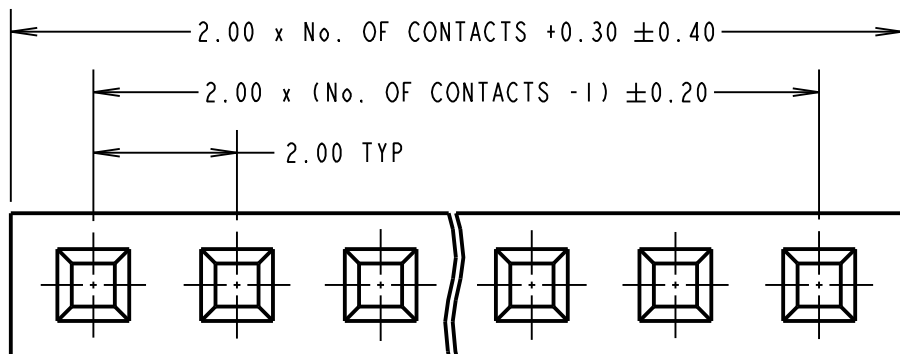

SPECIFICATION:

MATERIAL

MOULDING = NYLON 66 UL94V-2, BLACK

ELECTRICAL:

CURRENT RATING = 1A AC/DC

VOLTAGE RATING = 250V AC/DC MAX

DIELECTRIC WITHSTANDING VOLTAGE = 800V AC FOR 1 MINUTE

INSULATION RESISTANCE = 1000MΩ MIN

ENVIRONMENTAL:

OPERATING TEMPERATURE = -25°C TO +85°C

NOTES:

- TO BE USED WITH CRIMP CONTACTS M22-30400XX (REELED) OR M22-30500XX (LOOSE).
- TRIANGLE PIN INDICATOR IS ON PIN 1 AND EVERY 5th PIN AFTER.
- MATING PIN LENGTH = 4.5mm MAX
4.0mm MIN

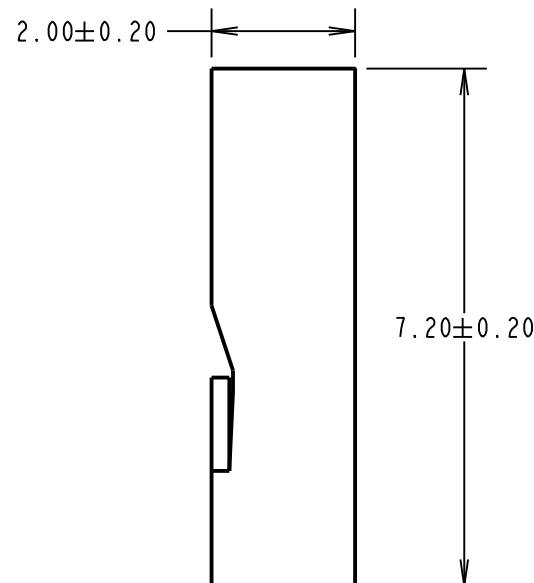

ORDER CODE:

M22-301XX00

No. OF CONTACTS:

MSP	14	24.07.17	20286
NAME	ISS.	DATE	C/NOTE
APPROVED: M.PERREN			
CHECKED: M.PLESTED			
DRAWN: I. SANDY			
CUSTOMER REF.:			
ASSEMBLY DRG:			

HARWIN

www.harwin.com
technical@harwin.com

THIS DRAWING AND ANY INFORMATION OR DESCRIPTIVE MATTER SET OUT HEREON ARE CONFIDENTIAL AND COPYRIGHT PROPERTY OF THE HARWIN GROUP AND MUST NOT BE DISCLOSED, LOANED, COPIED OR USED FOR MANUFACTURING, TENDERING OR FOR ANY OTHER PURPOSE WITHOUT THEIR WRITTEN PERMISSION.

TOLERANCES

X. = ±1mm
X.X = ±0.50mm
X.XX = ±0.10mm
X.XXX = ±0.01mm
ANGLES = ±5°
UNLESS STATED

MATERIAL:

SEE ABOVE

FINISH: SEE ABOVE

S/AREA: mm²

TITLE:

2.00mm SIL CRIMP
SOCKET HOUSING

DRAWING NUMBER:

M22-301XX00

SHT
2 OF 2