

REV.	DESCRIPTION	DATE	APPROVED
C	Mounting Hole Update	04/09/09	T. Y.
D	Removed -102 and -134 Parts	08/25/09	T. Y.
E	Tolerance Update on .475" Thickness	09/09/10	T. Y.
F	Updated Notes with Mounting Instructions	02/05/14	J. C.
G	Material Update	10/22/15	J. C.

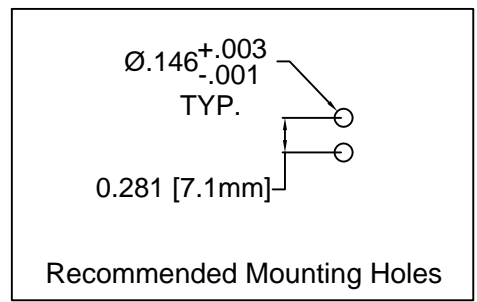
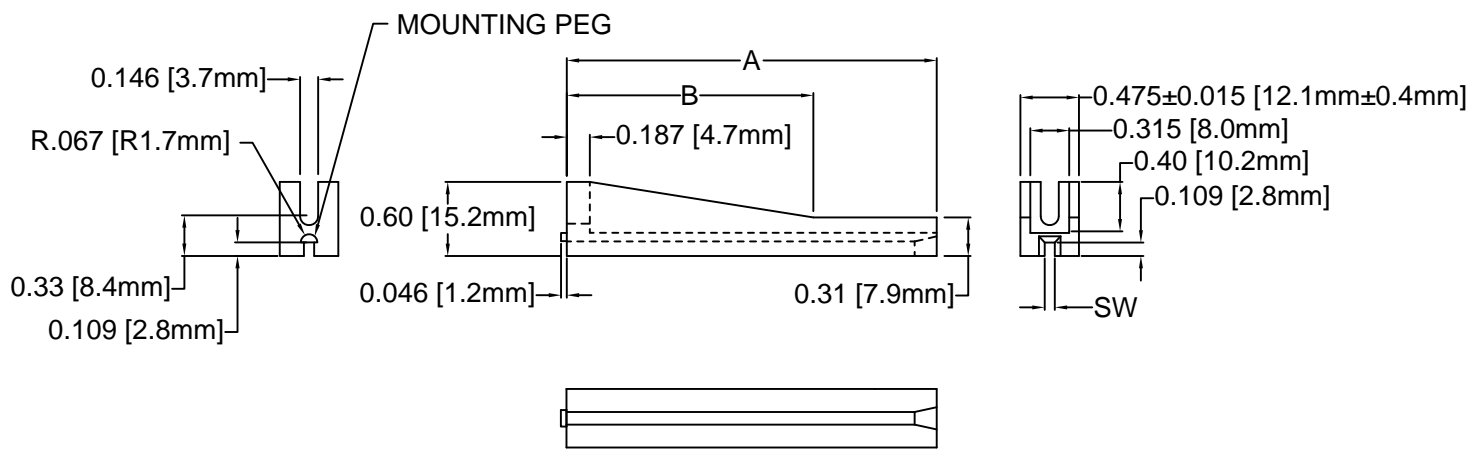

PART NO.	A ±.015 (.38)	B ±.015 (.38)	SW 1/16" PCB
VG2-2	2.0 (50.8)	1.5 (38.1)	.076 (1.9)
VG2-25	2.5 (63.5)	1.5 (38.1)	
VG2-3	3.0 (76.2)	2.0 (50.8)	
VG2-35	3.5 (88.9)		
VG2-4	4.0 (101.6)		
VG2-45	4.5 (114.3)		
VG2-5	5.0 (127.0)		
VG2-55	5.5 (139.7)		
VG2-6	6.0 (152.4)		

3. MOUNTING INSTRUCTIONS: INSERT MOUNTING PEG INTO .146" HOLE AND TAPPING SCREW THROUGH SECOND .146" HOLE. PITCH IS .281".
2. MATERIAL: NYLON 66, 15% GLASS, 94V-0, BLACK.
1. GENERAL SPECIFICATIONS: BIVAR MOLDED COMPONENT SPECIFICATION BV00-E101.

STANDARD TOLERANCE (UNLESS OTHERWISE SPECIFIED)		 4 THOMAS, IRVINE, CA. 92618 TEL: (949) 951-8808 FAX: (949) 951-3974			
DECIMALS	ANGULAR				
.X ±.1	X° ± 1°	 <b>TITLE:</b> VERTICAL PCB CARD GUIDE			
.XX ±.01					
.XXX ±.005		DESIGNED: <b>D. Green</b>	DATE: <b>11/22/02</b>	PART NO: <b>VG2-XX-XXX</b>	REVISION: <b>G</b>
CHECKED: <b>M. Chen</b>		DATE: <b>11/22/02</b>		CAGE CODE : <b>32559</b>	SHEET # <b>1</b> OF <b>1</b>
CAD GENERATED DOCUMENT. DO NOT MEASURE DRAWING.					

# Mouser Electronics

Authorized Distributor

Click to View Pricing, Inventory, Delivery & Lifecycle Information:

[BIVAR:](#)

[VG2-2](#) [VG2-25](#) [VG2-3](#) [VG2-35](#) [VG2-4](#) [VG2-5](#) [VG2-6](#) [VG2-45](#) [VG2-55](#)