

LOC	DIST	REVISIONS			
P	LTR	DESCRIPTION	DATE	DWN	APVD
DY	-	A	REVISED ECR-07-014309	15JUN2007	GKT LSF

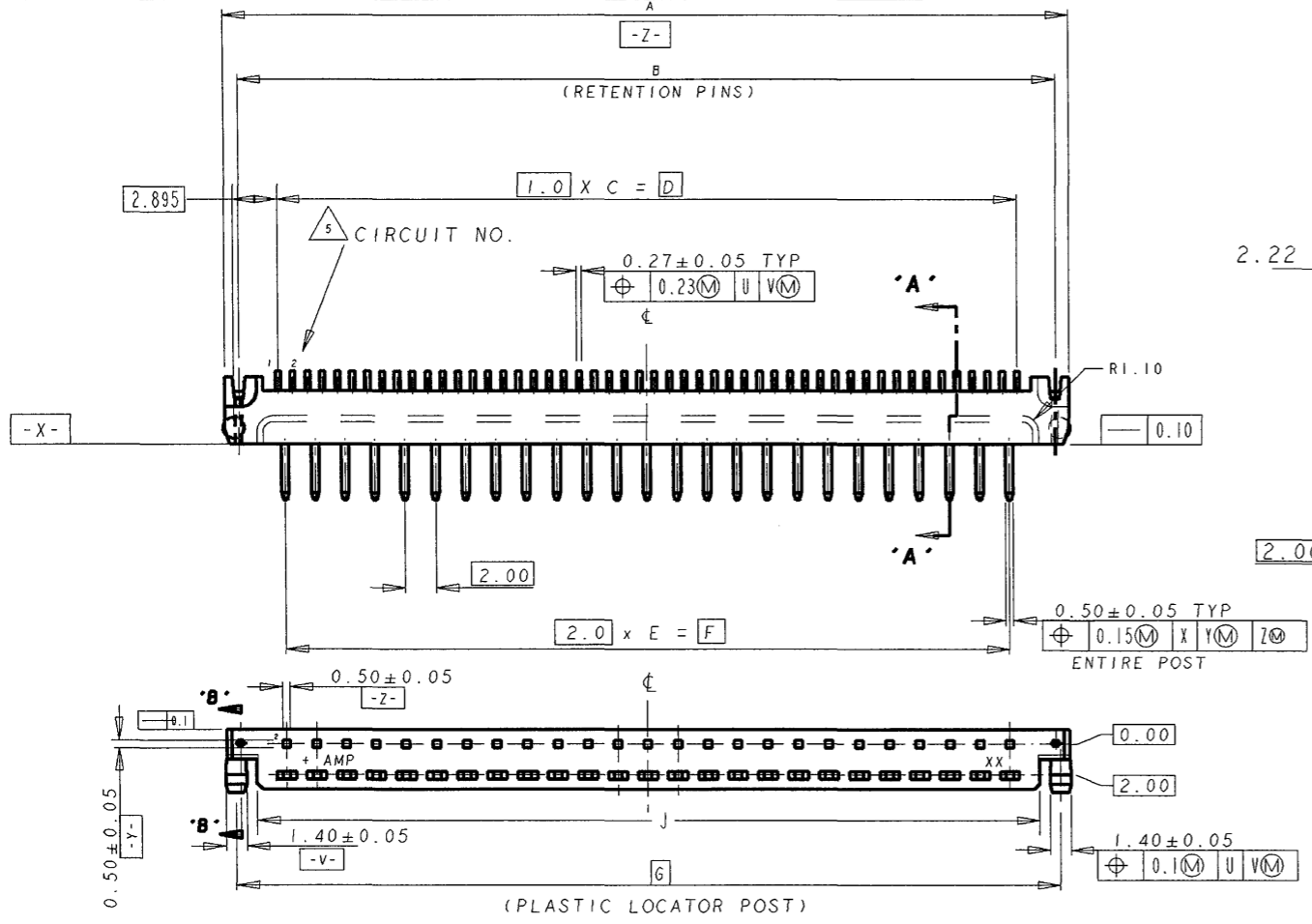

- NOTES:
- 1 MATERIAL: HOUSING: PPS, UL94-0, BLACK POST: COPPER ALLOY
  - 2 FINISH: CONTACT AREA: 0.76um GOLD OR GOLD FLASH OVER 0.76um Pd-Ni SOLDER AREA: 2.54um MIN MATTE TIN ALLOY UNDERPLATE: 1.3um MIN NICKEL ALL OVER
  - 3 POSITION NO. FOR REFERENCE ONLY
  - 4 ALL PCB CONTACT SURFACES OF SMT SOLDER TAILS TO BE A MAX OF 0.1 ABOVE -U- AND A MAX OF 0.05 BELOW -U- SUBJECT TO TOTAL 0.1
  - 5. ALL DIMENSIONS, EXCEPT STRAIGHTNESS TO BE MEASURED WITH BOW REMOVED

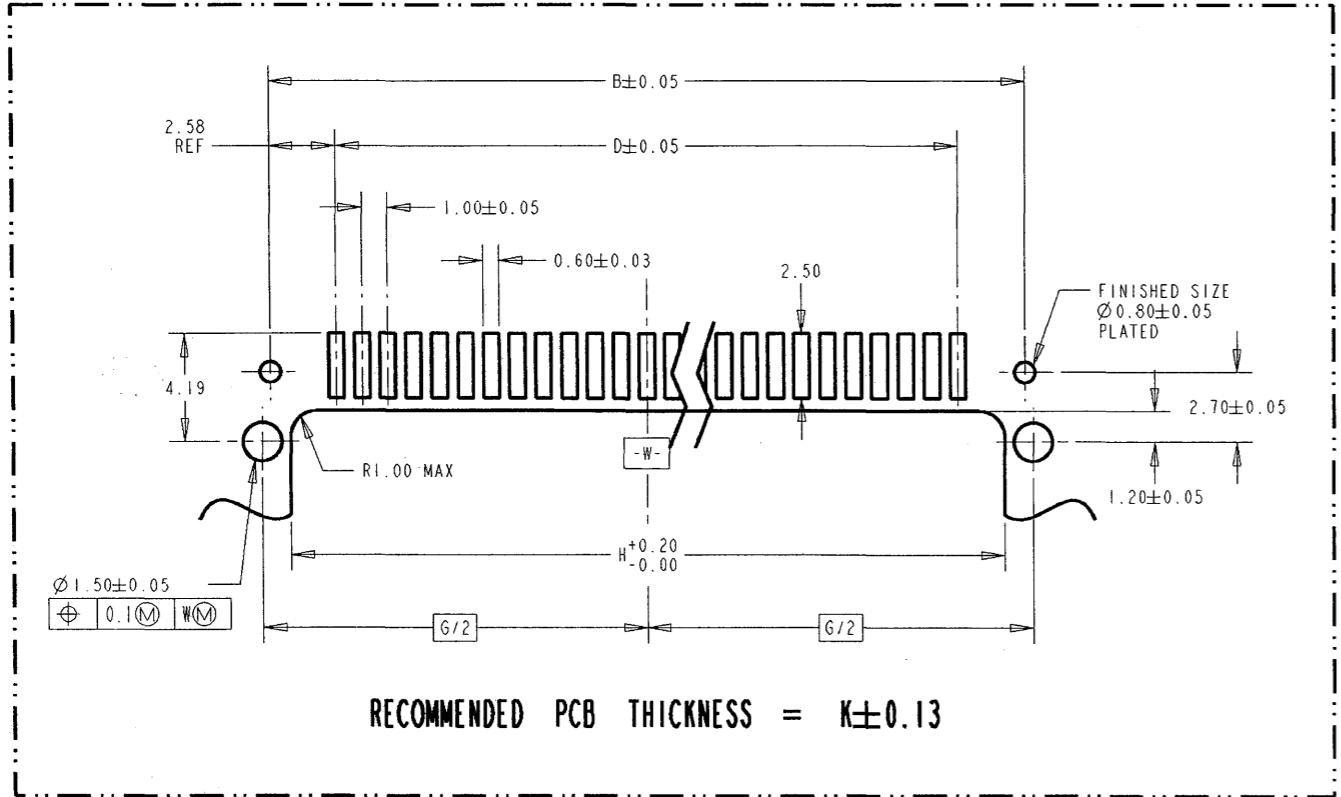
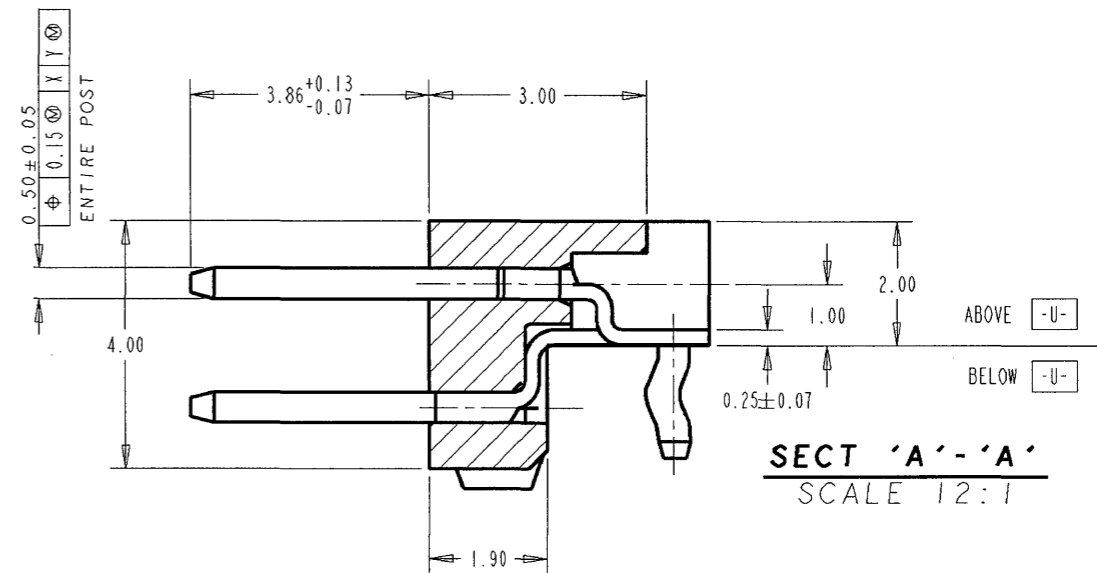

ACTIVE	REFER TO PG 2 OF 2	TAPE&REEL	0.8	52.10	52.58	54.79	48	24	49	49	54.15	56.03	-	25,45,46	50	1-5084108-4
ACTIVE	REFER TO PG 2 OF 2	TAPE&REEL	0.8	52.10	52.58	54.79	48	24	49	49	54.15	56.03	-	NIL	50	1-5084108-2
ACTIVE	-	TRAY	0.8	52.10	52.58	54.79	48	24	49	49	54.15	56.03	-	5, 6, 26	50	5084108-7
ACTIVE	-	TRAY	0.8	52.10	52.58	54.79	48	24	49	49	54.15	56.03	-844 (AT)	25,45,46	50	5084108-2
ACTIVE	-	TRAY	0.8	52.10	52.58	54.79	48	24	49	49	54.15	56.03	-840 (SCSI)	24,41,42	50	5084108-1
STATUS	REMARKS	PACKAGING	K	J	H	G	F	E	D	C	B	A	CUST. P/N FOR REF ONLY	POSTS OMITTED	POS	PART NO.

THIS DRAWING IS A CONTROLLED DOCUMENT FOR AMP INCORPORATED. IT IS SUBJECT TO CHANGE AND THE CONTROLLING ENGINEERING ORGANIZATION SHOULD BE CONTACTED FOR THE LATEST REVISION.

DWN: KW YAP 05JUL2005  
 CHK: WL CHOO 05JUL2005  
 APVD: SF LEONG 05JUL2005

**tyco Electronics** Tyco Electronics Singapore Pte. Ltd.

NAME: HEADER ASSEMBLY, 2mm AMPMODU SMT, R/A, D/R

PRODUCT SPEC: -  
 APPLICATION SPEC: -  
 WEIGHT: -

DIMENSIONS: mm  
 TOLERANCES UNLESS OTHERWISE SPECIFIED:  
 0 PLC ±0.2  
 1 PLC ±0.2  
 2 PLC ±0.25  
 3 PLC ±0.3  
 4 PLC ±0.3  
 ANGLES ±3°

MATERIAL: 1  
 FINISH: 2

SIZE: A2  
 CAGE CODE: 00779  
 DRAWING NO: G-5084108  
 SCALE: 3:1  
 SHEET: 1 of 2  
 REV: A

CUSTOMER DRAWING

LOC	DIST	REVISIONS			
F	LTR	DESCRIPTION	DATE	DWN	APVD
DY	-	SEE SHEET 1	-	-	-

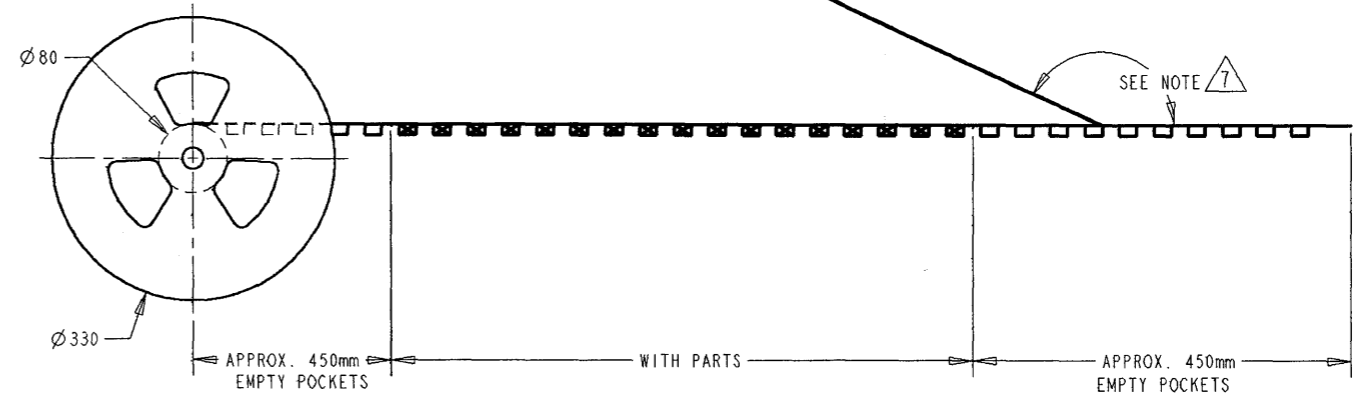
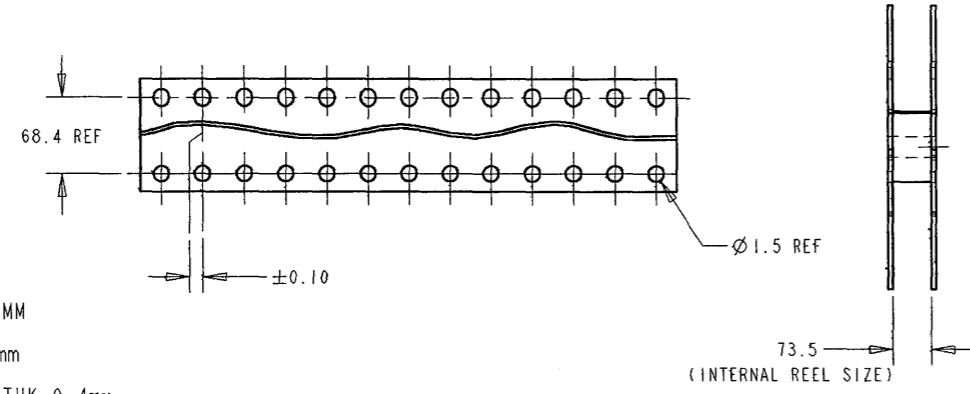
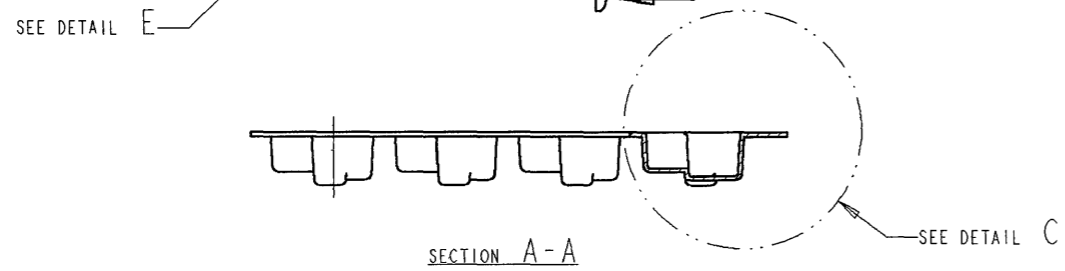
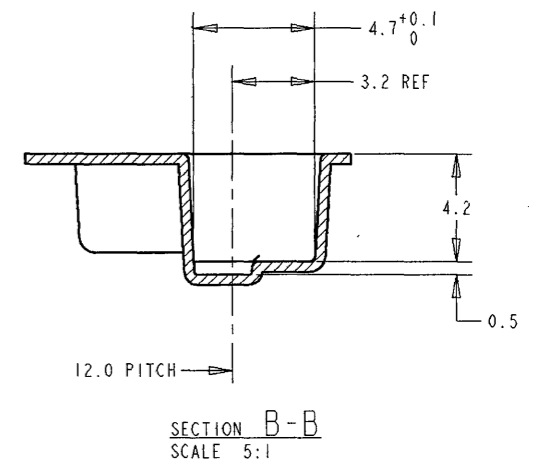
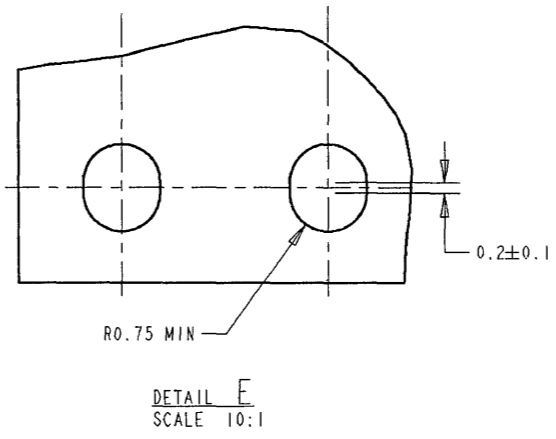
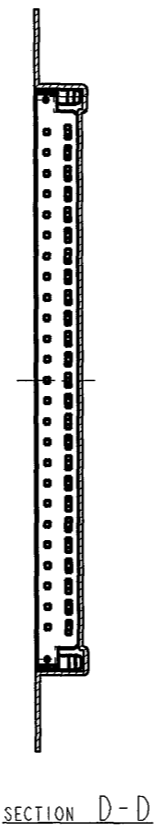
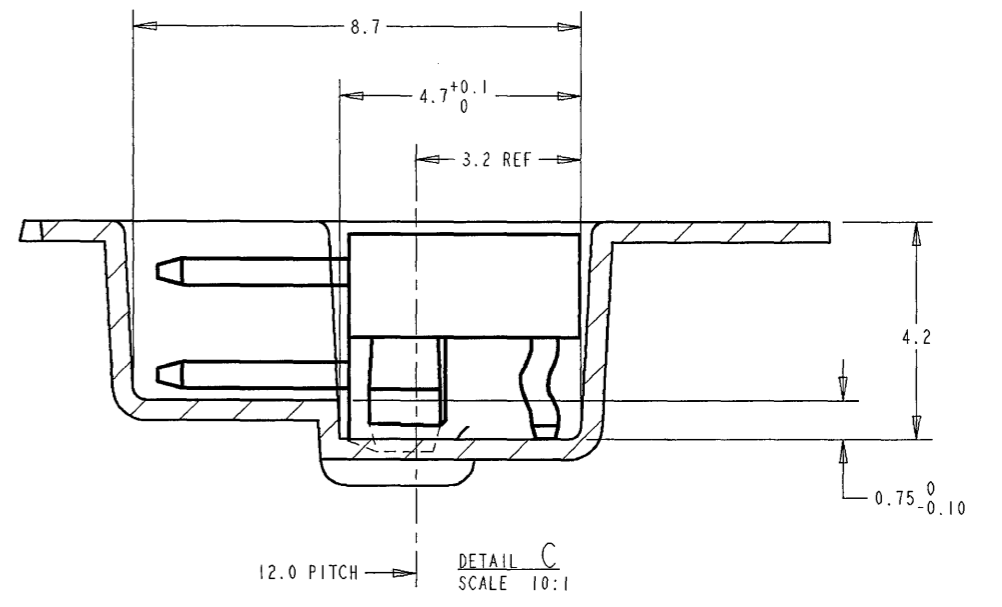
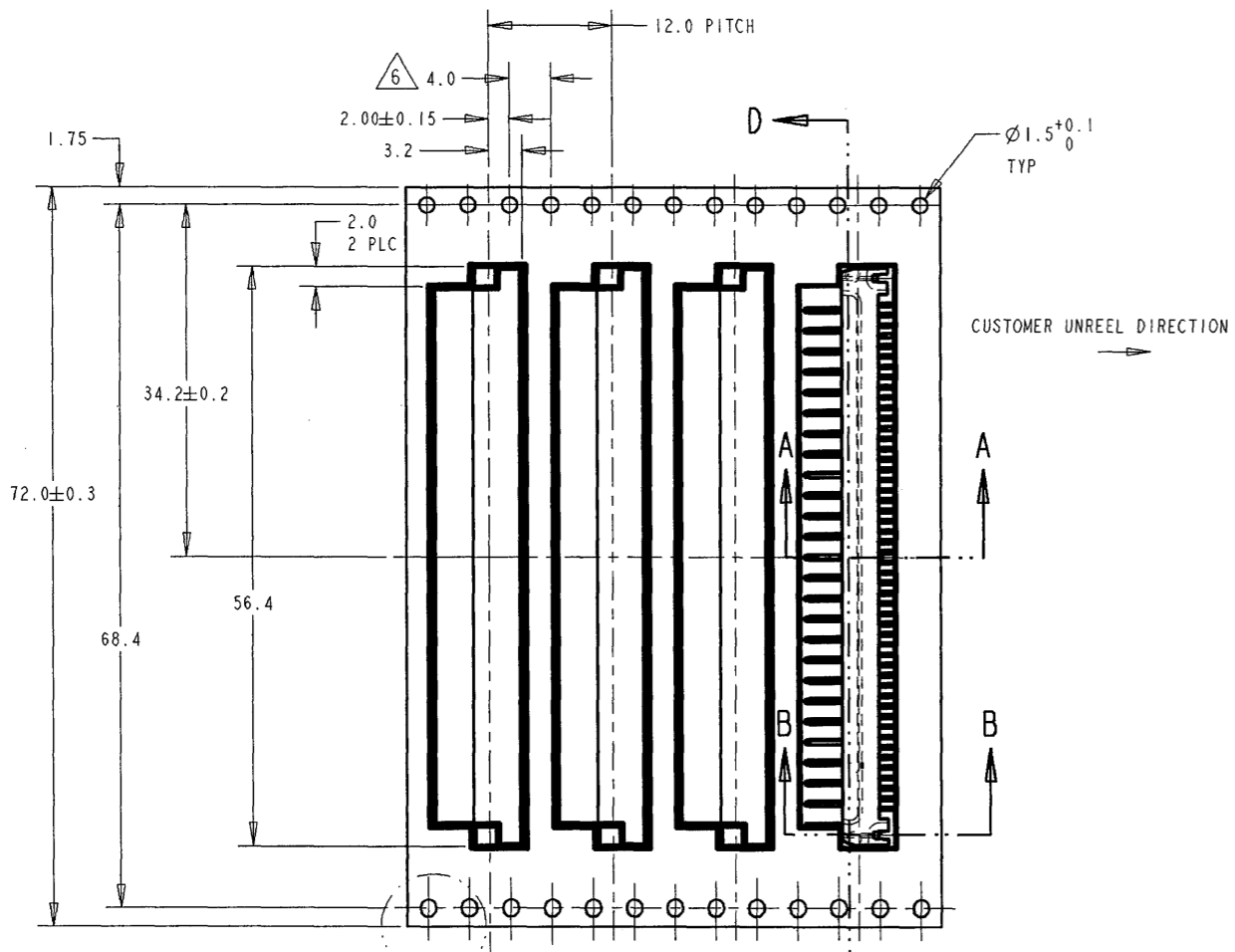

- NOTES:
- ALL DIMENSIONS IN MM
  - GENERAL TOL:  $\pm 0.1$ mm
  - MATERIAL: HOUSING THK 0.4mm
  - PACKAGING PER REEL: 1115 POCKETS; OD: 330mm, ID: 100mm
  - QTY PER REEL: 1000 PCS  
10 PITCHES CUMULATIVE TOLERANCE ON TAPE  $\pm 0.2$ mm
  - PEELING STRENGTH: 10g-70g  
PEELING ANGLE 165-180  
PEELING SPEED: 300mm/MINUTE
  - TAPE & REEL PACKAGING APPLY TO P/N: 1-84108-2, 1-84108-4

TAPE & REEL PACKAGING

THIS DRAWING IS A CONTROLLED DOCUMENT FOR AMP INCORPORATED. IT IS SUBJECT TO CHANGE AND THE CONTROLLING ENGINEERING ORGANIZATION SHOULD BE CONTACTED FOR THE LATEST REVISION.		DWN 05 JUL 2005	Tyco Electronics Singapore Pte. Ltd.														
DIMENSIONS: mm		CHK 05 JUL 2005															
TOLERANCES UNLESS OTHERWISE SPECIFIED:		APVD 05 JUL 2005	NAME														
<table border="1"> <tr><td>0 PLC</td><td><math>\pm 0.2</math></td></tr> <tr><td>1 PLC</td><td><math>\pm 0.2</math></td></tr> <tr><td>2 PLC</td><td><math>\pm 0.25</math></td></tr> <tr><td>3 PLC</td><td><math>\pm 0.3</math></td></tr> <tr><td>4 PLC</td><td><math>\pm 0.3</math></td></tr> <tr><td>ANGLES</td><td><math>\pm 0.3</math></td></tr> <tr><td>FINISH</td><td><math>\pm 3^\circ</math></td></tr> </table>		0 PLC	$\pm 0.2$	1 PLC	$\pm 0.2$	2 PLC	$\pm 0.25$	3 PLC	$\pm 0.3$	4 PLC	$\pm 0.3$	ANGLES	$\pm 0.3$	FINISH	$\pm 3^\circ$	PRODUCT SPEC	HEADER ASSEMBLY, 2mm AMPMODU SMT, R/A, D/R
0 PLC	$\pm 0.2$																
1 PLC	$\pm 0.2$																
2 PLC	$\pm 0.25$																
3 PLC	$\pm 0.3$																
4 PLC	$\pm 0.3$																
ANGLES	$\pm 0.3$																
FINISH	$\pm 3^\circ$																
MATERIAL		APPLICATION SPEC	SIZE														
		WEIGHT	A2														
		CUSTOMER DRAWING	CAGE CODE														
			00779														
		DRAWING NO	C-5084108														
		SCALE	3:1														
		SHEET	2 of 2														
		REV	A														

# Mouser Electronics

Authorized Distributor

Click to View Pricing, Inventory, Delivery & Lifecycle Information:

[TE Connectivity:](#)

[1-5084108-2](#)