

REVISIONS			
REV	DESCRIPTION	DATE	APPRD.
A	PROPOSAL DRAWING	NOV13/07	K.L.

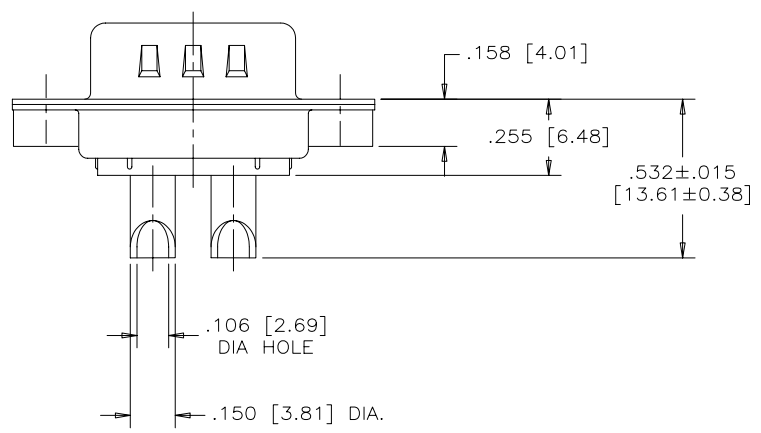
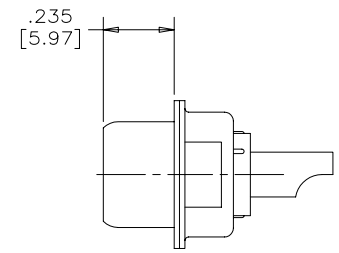
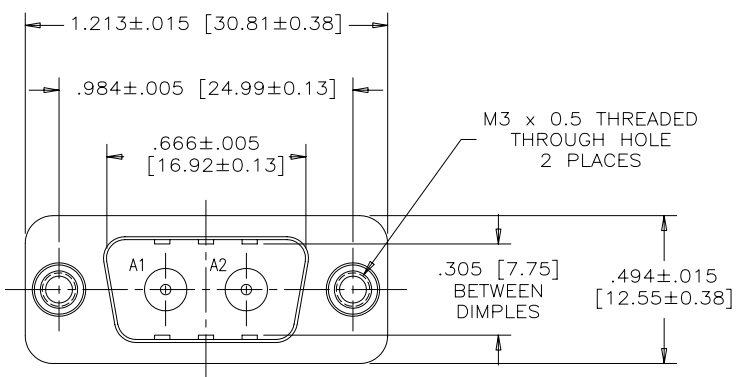

MECHANICAL DATA:

- MATERIALS:** ALL MATERIALS ARE RoHS COMPLIANT PER EU DIRECTIVE 2002/95/EC AND AMENDMENTS.
- SHELLS:** STAMPED STEEL, TIN PLATED.
- INSERT:** HIGH TEMPERATURE RESISTANT THERMOPLASTIC, GLASS REINFORCED, FLAMMABILITY RATING UL94V-0, BLACK.
- CONTACT:** COPPER ALLOY, 30μ" [0.76 MICRONS] GOLD PLATED OVER NICKEL.
- MOUNTING HARDWARE:** STEEL, MATTE TIN PLATED

ELECTRICAL DATA:

CONTACT RESISTANCE	5 MILLIOHMS MAX.
INSULATION RESISTANCE	3000 MEGOHMS MIN.
CURRENT RATING	20 AMP
CAPACITANCE	5,000 pF ±15%

ORDERING CODE: F C E 1 7 - E 2 W 2 P L - 6 E 1

SERIES _____

SHELL SIZE AND ARRANGEMENT _____

CONNECTOR STYLE _____
P=PIN

SOLDER CUP CONTACT (12 AWG SIZE) _____

MOUNTING _____
6=M3 x 0.5 THREADED HOLES

MODIFIER
1=SPECIAL CONNECTOR WITH
2 X 2500pF CAPACITORS
(TOTAL 5000pF) PER POSITION

FILTER CAPACITANCE
SEE MODIFIER DETAILS

DRAWN <i>K. LAMBIE</i>	DATE <i>NOV13/07</i>
CHECKED	
DESIGNED	
APPROVED	
INDUSTRIAL ENG. APPRD.	
ENGINEERING RELEASE NO.	
REF.	
DIMENSIONS ARE IN INCHES [mm]	CODE IDENT. NO. 03554

Amphenol Canada Corp.			
FCE17 SERIES FILTERED COMBO D-SUB CONNECTOR, 2W2 ARRANGEMENT, POWER PIN CONTACT, SOLDER CUP FOR 12 AWG WIRE, 5000pF, M3 THREAD, RoHS COMPLIANT			
DWG	DRAWING NO.	REV.	
C	P-FCE17-E2W2PL-6E1	A	
SCALE	3/1	WT.	-----
SURF.	-----	SHEET	1 of 1

THIS DOCUMENT CONTAINS PROPRIETARY INFORMATION AND SUCH INFORMATION MAY NOT BE DISCLOSED TO OTHERS FOR ANY PURPOSE OR USED FOR MANUFACTURING PURPOSES WITHOUT WRITTEN PERMISSION FROM AMPHENOL CANADA CORP.

Mouser Electronics

Authorized Distributor

Click to View Pricing, Inventory, Delivery & Lifecycle Information:

[Amphenol:](#)

[FCE17-A3W3PR-K81](#) [FCE17-B5W5S-K470](#) [FCE17-E2W2PL-6E1](#)