

PART NAME: KNOB SCALE: 1:1 DATE: 12/14/68 DR. BY M.S.

THIS DRAWING IS THE PROPERTY OF DAVIES MOLDING COMPANY, IS SUBMITTED SOLELY AS A DESIGN OR ENGINEERING PROJECT. WE ACCEPT NO RESPONSIBILITY WHATSOEVER FOR THE PRACTICAL APPLICATION OF THE PIECES MADE TO THIS DESIGN.



DESIGNERS & MANUFACTURERS OF KNOBS, HANDLES, CASES & CUSTOM PLASTIC COMPONENTS

P/N 4005

MOLD # 4005

CAVITY 4005

PLUNGER 4005

TOP PIN 4005

Ⓐ TOP PIN SPRING WASHER 0.032

OUTER PIN 4005

INNER PIN 4005-1

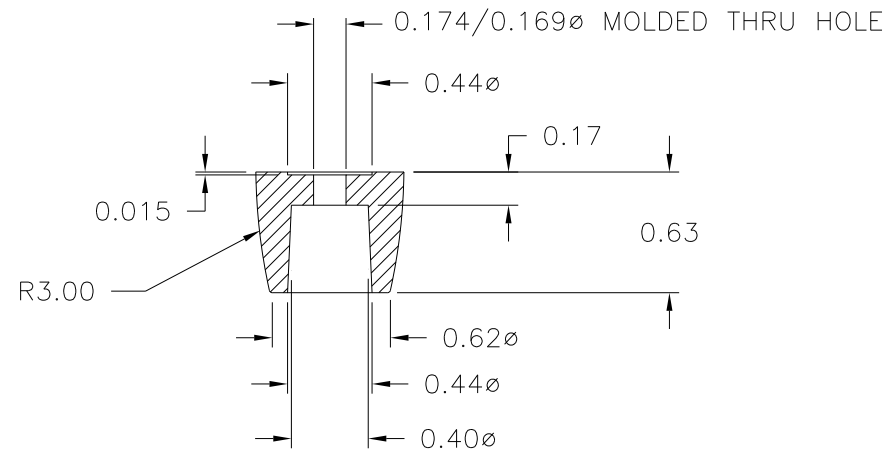
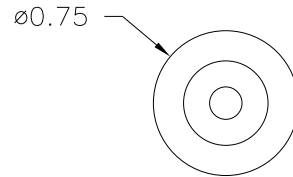

MATERIAL: G.P. PHENOLIC (B11)

COLOR: BLACK

TOLERANCES: UNLESS OTHERWISE SPECIFIED		DO NOT SCALE DRAWING			
DECIMALS: X.XXX ± .005 X.XX ± .015		MM: X.XX ± 0.15MM X.X ± 0.4MM		A	CORRECTED TOOLING BOX & ADDED SPRING WASHER
FRACTIONS ± 1/64		ANG. ± 1°		TS	1/27/03
				-	CAD/REDRAWN
				HD	9/2/97
CHANGES					

Mouser Electronics

Authorized Distributor

Click to View Pricing, Inventory, Delivery & Lifecycle Information:

[Davies Molding:](#)

[4005](#)