

# NHD-C24064WO-ATFH#-3V3

## COG (Chip-On-Glass) Liquid Crystal Display Module

NHD-	Newhaven Display
C24064-	240 x 64 Pixels
WO-	Model
A-	Transflective
T-	White LED Backlight
F-	FSTN Positive
H-	6:00 Optimal View, Wide Temperature
3V3-	3.3V LCD, 3.5V Backlight

**RoHS Compliant**

**Newhaven Display International, Inc.**

2661 Galvin Ct.

Elgin IL, 60124

Ph: 847-844-8795

Fax: 847-844-8796

[www.newhavendisplay.com](http://www.newhavendisplay.com)

[nhtech@newhavendisplay.com](mailto:nhtech@newhavendisplay.com)

[nhsales@newhavendisplay.com](mailto:nhsales@newhavendisplay.com)

## Document Revision History

Revision	Date	Description	Changed by
0	5/10/07	Initial Release	-
1	9/23/09	User guide reformat	BE
2	10/08/09	Updated Backlight Information	MC
3	11/20/09	Updated backlight supply current typ.	MC
4	8/26/11	Mechanical Drawing Updated	TJ
5	2/3/12	Controller link updated	AK
6	11/16/12	Electrical characteristics & Wiring diagram updated	AK
7	4/4/13	Backlight mating connector updated	AK
8	2/25/14	Serial interface timing added	AK
10	12/21/16	Electrical Characteristics Updated	SB
11	2/17/17	Backlight Characteristics Updated	SB

## Functions and Features

- 240 x 64 pixels
- Built-in DUAL ST7565S controllers
- +3.3V power supply
- Parallel/Serial Interface
- RoHS Compliant

# Mechanical Drawing

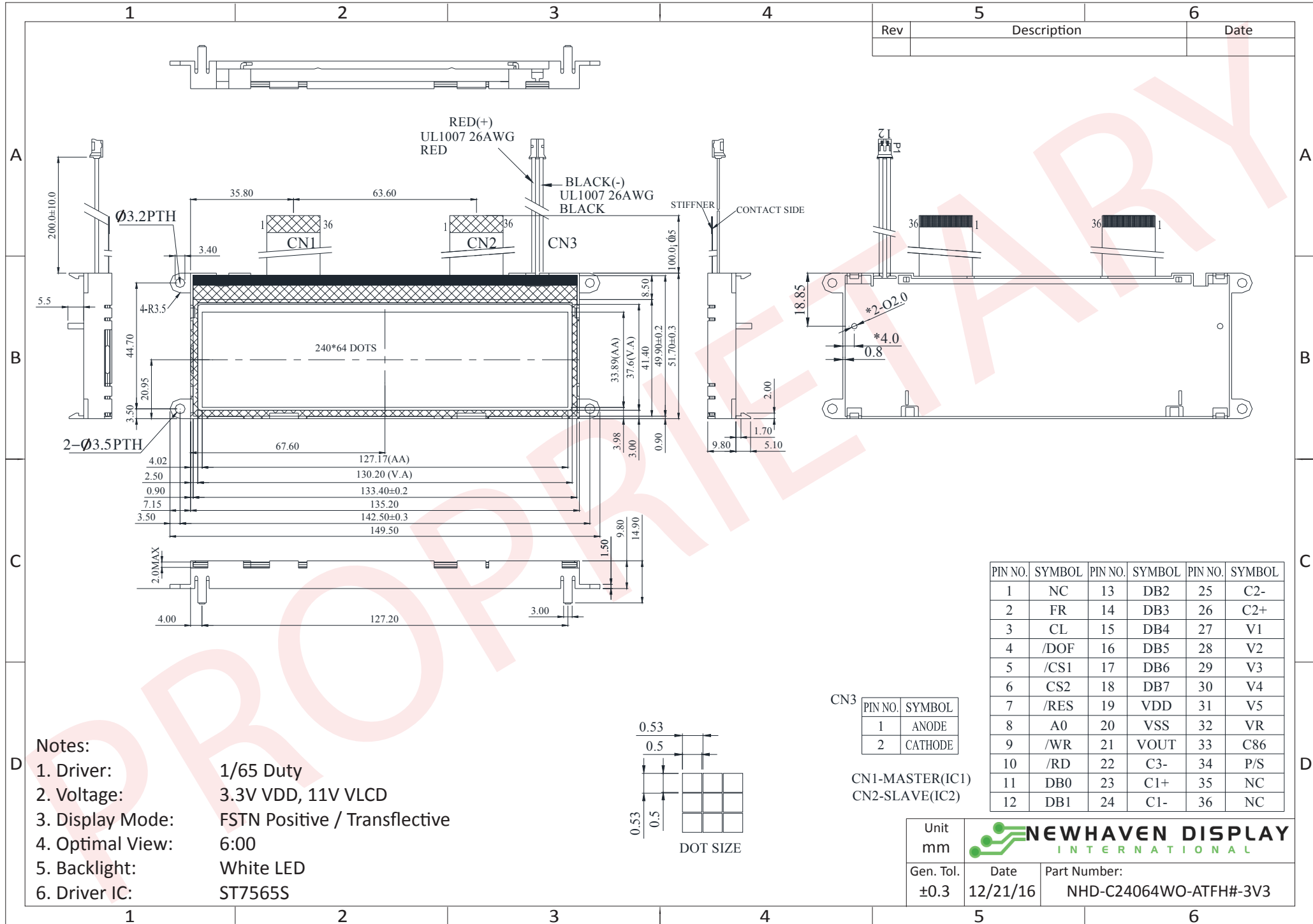

Rev	Description	Date

- Notes:**
- Driver: 1/65 Duty
  - Voltage: 3.3V VDD, 11V VLCD
  - Display Mode: FSTN Positive / Transflective
  - Optimal View: 6:00
  - Backlight: White LED
  - Driver IC: ST7565S

Unit mm	<b>NEWHAVEN DISPLAY</b> INTERNATIONAL	
Gen. Tol. ±0.3	Date 12/21/16	Part Number: NHD-C24064WO-ATFH#-3V3

## Pin Description

Pin No.	Symbol	External Connection	Function Description
1	NC	-	No Connect
2	FR	-	Alternating current signal (tie both FR pins together)
3	CL	-	Clock input terminal (tie both CL pins together)
4	/DOF	-	Blanking control output (tie both /DOF pins together)
5	/CS1	MPU	Active LOW Chip Select Signal
6	CS2	MPU	Active HIGH Chip Select Signal (can tie HIGH)
7	/RES	MPU	Active LOW Reset signal
8	A0	MPU	Register Select. 0: Instruction; 1: Data
9	/WR R/W	MPU	In 8080 mode: Active LOW Write signal In 6800 mode: R/W=1 for Read; R/W=0 for Write
10	/RD E	MPU	In 8080 mode: Active LOW Read signal In 6800 mode: Enable signal; Falling edge triggered
11	DB0	MPU	Parallel Interface DB0-DB7: Bi-directional 8-bit data bus  Serial Interface: DB0-DB5: No connect in serial mode  DB6 = Serial clock DB7 = Serial data input
12	DB1		
13	DB2		
14	DB3		
15	DB4		
16	DB5		
17	DB6 (SCL)		
18	DB7 (SI)		
19	V <sub>DD</sub>	Power Supply	Supply Voltage for Logic (3.3V)
20	V <sub>SS</sub>	Power Supply	Ground
21	V <sub>OUT</sub>	Power Supply	1.0uF Cap to Ground
22	C3-	Power Supply	1.0uF-2.2uF cap to C1+ (Pin-23)
23	C1+	Power Supply	1.0uF-2.2uF cap to C3- (Pin-22) and C1- (Pin-24)
24	C1-	Power Supply	1.0uF-2.2uF cap to C1+ (Pin-23)
25	C2-	Power Supply	1.0uF-2.2uF cap to C2+ (Pin-26)
26	C2+	Power Supply	1.0uF-2.2uF cap to C2-(Pin-25)
27	V1	Power Supply	1.0uF-2.2uF cap to VDD
28	V2	Power Supply	1.0uF-2.2uF cap to VDD
29	V3	Power Supply	1.0uF-2.2uF cap to VDD
30	V4	Power Supply	1.0uF-2.2uF cap to VDD
31	V5	Power Supply	1.0uF-2.2uF cap to VDD
32	VR	-	No connection
33	C86	MPU	Select MPU interface pin. C86 = H: 6800; C86 = L: 8080
34	P/S	MPU	Parallel/Serial select. PS = H: Parallel; PS = L: Serial
35	NC	-	No connection
36	NC	-	No connection

**Recommended LCD connectors:** 0.5mm pitch pins. Molex p/n: 54132-3697

**Backlight connector:** A2001H-02P      **Mates with:** A2001WR-2P, A2001WR-S-2P, A2001WV-2P, A2001WV-S-2P

# Wiring Diagram

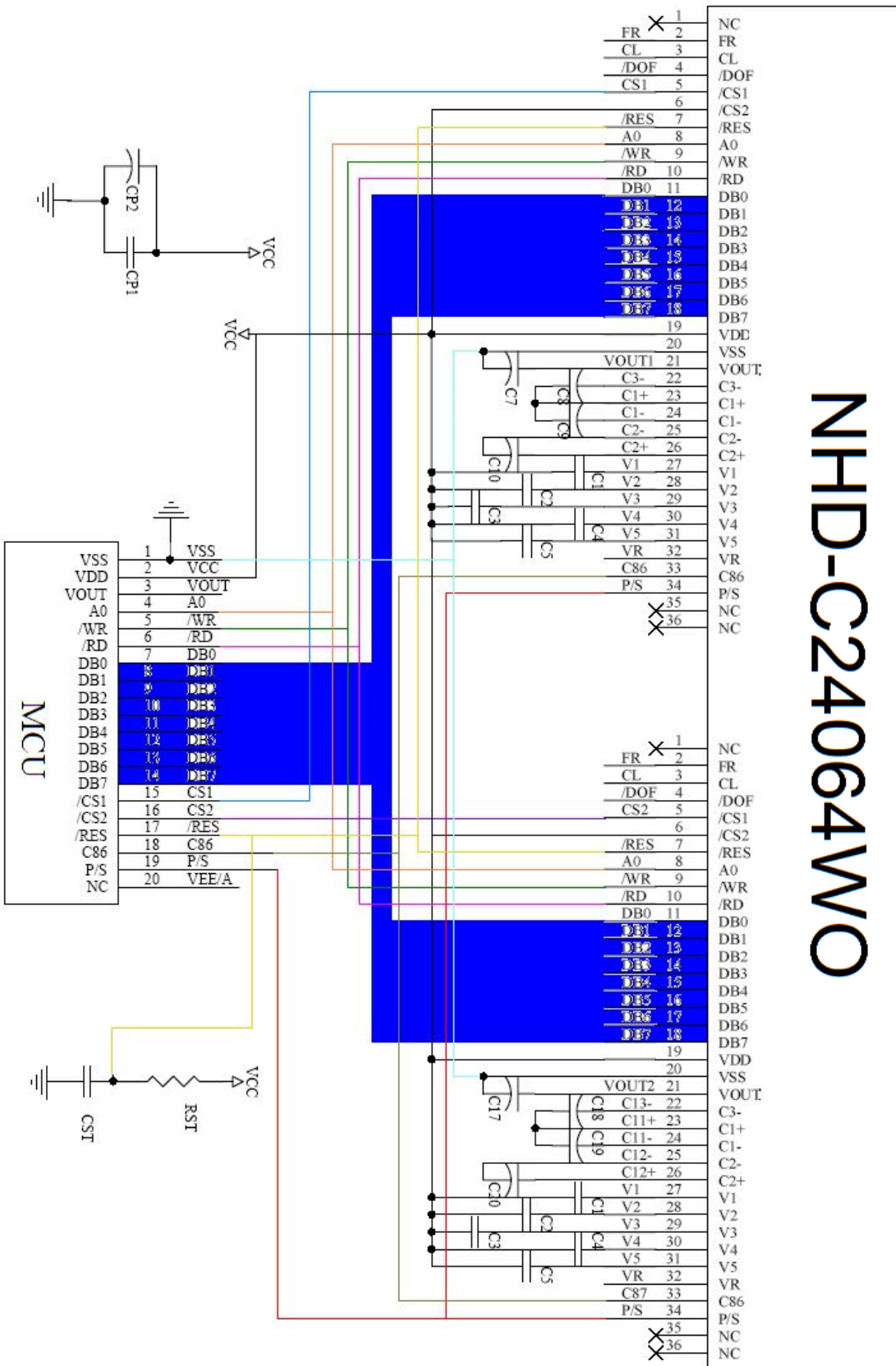

# NHD-C24064W0

## Electrical Characteristics

Item	Symbol	Condition	Min.	Typ.	Max.	Unit
Operating Temperature Range	$T_{OP}$	Absolute Max	-20	-	+70	°C
Storage Temperature Range	$T_{ST}$	Absolute Max	-30	-	+80	°C
Supply Voltage	$V_{DD}$	-	3.0	3.3	3.6	V
Supply Current	$I_{DD}$	$V_{DD} = 3.3V$ $T_{OP} = 25^{\circ}C$	0.5	1.5	2.5	mA
Supply for LCD (contrast)	$V_{LCD}$		10.6	11	11.4	V
"H" Level input	$V_{IH}$	-	$0.8 * V_{DD}$	-	$V_{DD}$	V
"L" Level input	$V_{IL}$	-	$V_{SS}$	-	$0.2 * V_{DD}$	V
"H" Level output	$V_{OH}$	-	$0.8 * V_{DD}$	-	$V_{DD}$	V
"L" Level output	$V_{OL}$	-	$V_{SS}$	-	$0.2 * V_{DD}$	V
Backlight Supply Voltage	$V_{LED}$	-	3.4	3.5	3.6	V
Backlight Supply current	$I_{LED}$	$V_{LED} = 3.5V$	35	110	140	mA

## Optical Characteristics

Item	Symbol	Condition	Min.	Typ.	Max.	Unit
Optimal Viewing Angles	Top	$CR \geq 2$	-	30	-	°
	Bottom		-	60	-	°
	Left		-	45	-	°
	Right		-	45	-	°
Contrast Ratio	CR	-	-	5	-	-
Response Time	Rise	$T_{OP} = 25^{\circ}C$	-	200	300	ms
	Fall		-	250	350	ms

## Controller Information

Built-in ST7565S controller.

Please download specification at [http://www.newhavendisplay.com/app\\_notes/ST7565S.pdf](http://www.newhavendisplay.com/app_notes/ST7565S.pdf)

## Table of Commands

Command	Command Code									Function				
	A0	/RD	/WR	D7	D6	D5	D4	D3	D2		D1	D0		
(1) Display ON/OFF	0	1	0	1	0	1	0	1	1	1	0	1	LCD display ON/OFF 0: OFF, 1: ON	
(2) Display start line set	0	1	0	0	1	Display start address						Sets the display RAM display start line address		
(3) Page address set	0	1	0	1	0	1	1	Page address				Sets the display RAM page address		
(4) Column address set upper bit	0	1	0	0	0	0	1	Most significant column address				Sets the most significant 4 bits of the display RAM column address.		
Column address set lower bit	0	1	0	0	0	0	0	Least significant column address				Sets the least significant 4 bits of the display RAM column address.		
(5) Status read	0	0	1	Status				0	0	0	0	0	Reads the status data	
(6) Display data write	1	1	0	Write data							Writes to the display RAM			
(7) Display data read	1	0	1	Read data							Reads from the display RAM			
(8) ADC select	0	1	0	1	0	1	0	0	0	0	0	1	Sets the display RAM address SEG output correspondence 0: normal, 1: reverse	
(9) Display normal/reverse	0	1	0	1	0	1	0	0	1	1	0	1	Sets the LCD display normal/reverse 0: normal, 1: reverse	
(10) Display all points ON/OFF	0	1	0	1	0	1	0	0	1	0	0	1	Display all points 0: normal display 1: all points ON	
(11) LCD bias set	0	1	0	1	0	1	0	0	0	1	0	1	Sets the LCD drive voltage bias ratio 0: 1/9 bias, 1: 1/7 bias (ST7565S)	
(12) Read/modify/write	0	1	0	1	1	1	0	0	0	0	0	0	Column address increment At write: +1 At read: 0	
(13) End	0	1	0	1	1	1	0	1	1	1	0	0	Clear read/modify/write	
(14) Reset	0	1	0	1	1	1	0	0	0	0	1	0	Internal reset	
(15) Common output mode select	0	1	0	1	1	0	0	0	*	*	*	*	Select COM output scan direction 0: normal direction 1: reverse direction	
(16) Power control set	0	1	0	0	0	1	0	1	Operating mode			Select internal power supply operating mode		
(17) V <sub>s</sub> voltage regulator internal resistor ratio set	0	1	0	0	0	1	0	0	Resistor ratio			Select internal resistor ratio(Rb/Ra) mode		
(18) Electronic volume mode set	0	1	0	1	0	0	0	0	0	0	0	1	Set the V <sub>s</sub> output voltage electronic volume register	
Electronic volume register set				0	0	Electronic volume value								
(19) Static indicator ON/OFF	0	1	0	1	0	1	0	1	1	0	0	1	0: OFF, 1: ON	
Static indicator register set				0	0	0	0	0	0	0	0	0	Mode	Set the flashing mode
(20) Booster ratio set	0	1	0	1	1	1	1	1	0	0	0	0	select booster ratio 00: 2x,3x,4x 01: 5x 11: 6x	
(21) Power saver													Display OFF and display all points ON compound command	
(22) NOP	0	1	0	1	1	1	0	0	0	0	1	1	Command for non-operation	
(23) Test	0	1	0	1	1	1	1	*	*	*	*	*	Command for IC test. Do not use this command	

# Timing Characteristics

## 8080 Series MPU

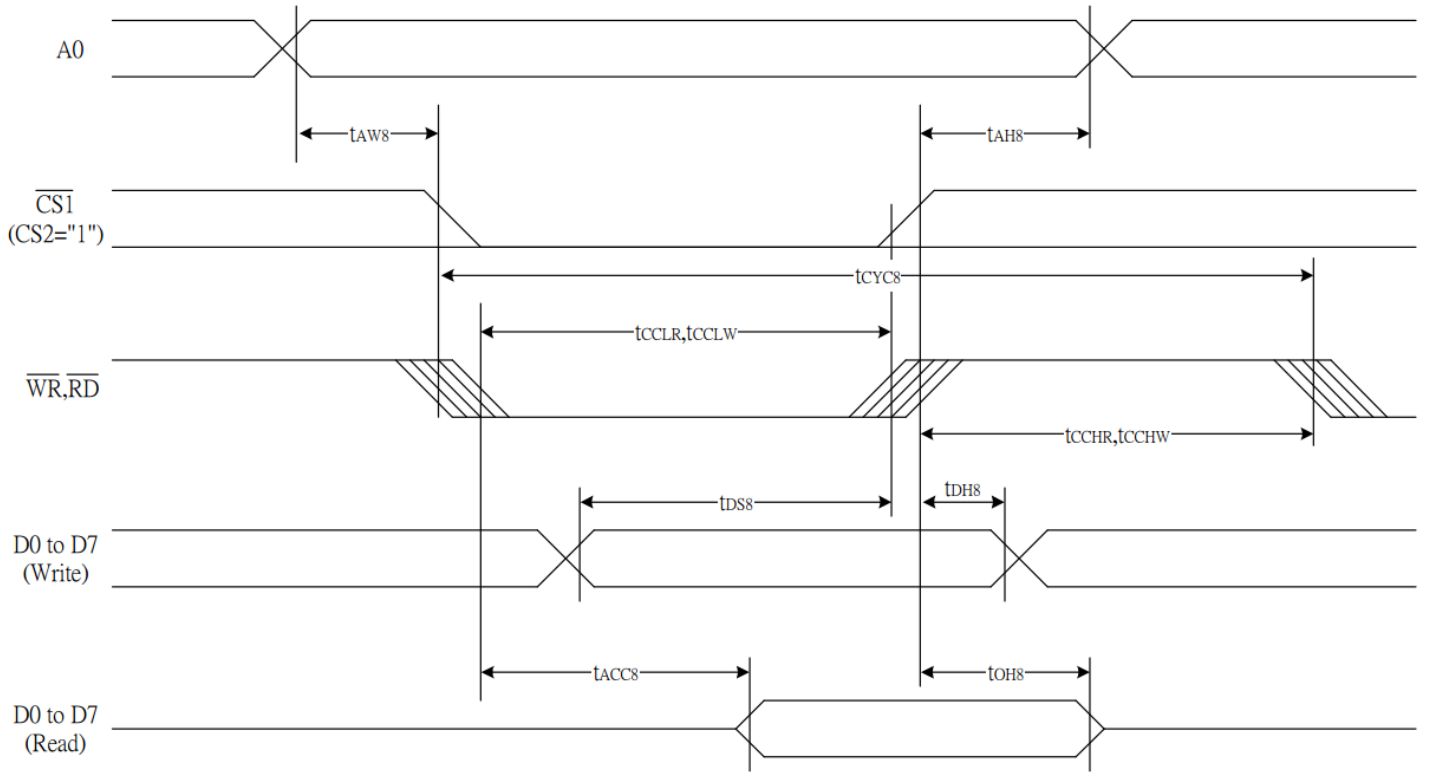

Item	Signal	Symbol	Condition	Rating		Units
				Min.	Max.	
Address hold time	A0	$t_{AH8}$		0	—	Ns
Address setup time		$t_{AW8}$		0	—	
System cycle time		$t_{CYC8}$		240	—	
Enable L pulse width (WRITE)	WR	$t_{CCLW}$		80	—	
Enable H pulse width (WRITE)		$t_{CCHW}$		80	—	
Enable L pulse width (READ)	RD	$t_{CCLR}$		140	—	
Enable H pulse width (READ)		$t_{CCHR}$		80	—	
WRITE Data setup time	D0 to D7	$t_{DS8}$		40	—	
WRITE Address hold time		$t_{DH8}$		10	—	
READ access time		$t_{ACC8}$	$C_L = 100 \text{ pF}$	—	70	
READ Output disable time		$t_{OH8}$	$C_L = 100 \text{ pF}$	5	50	



## 6800 Series MPU

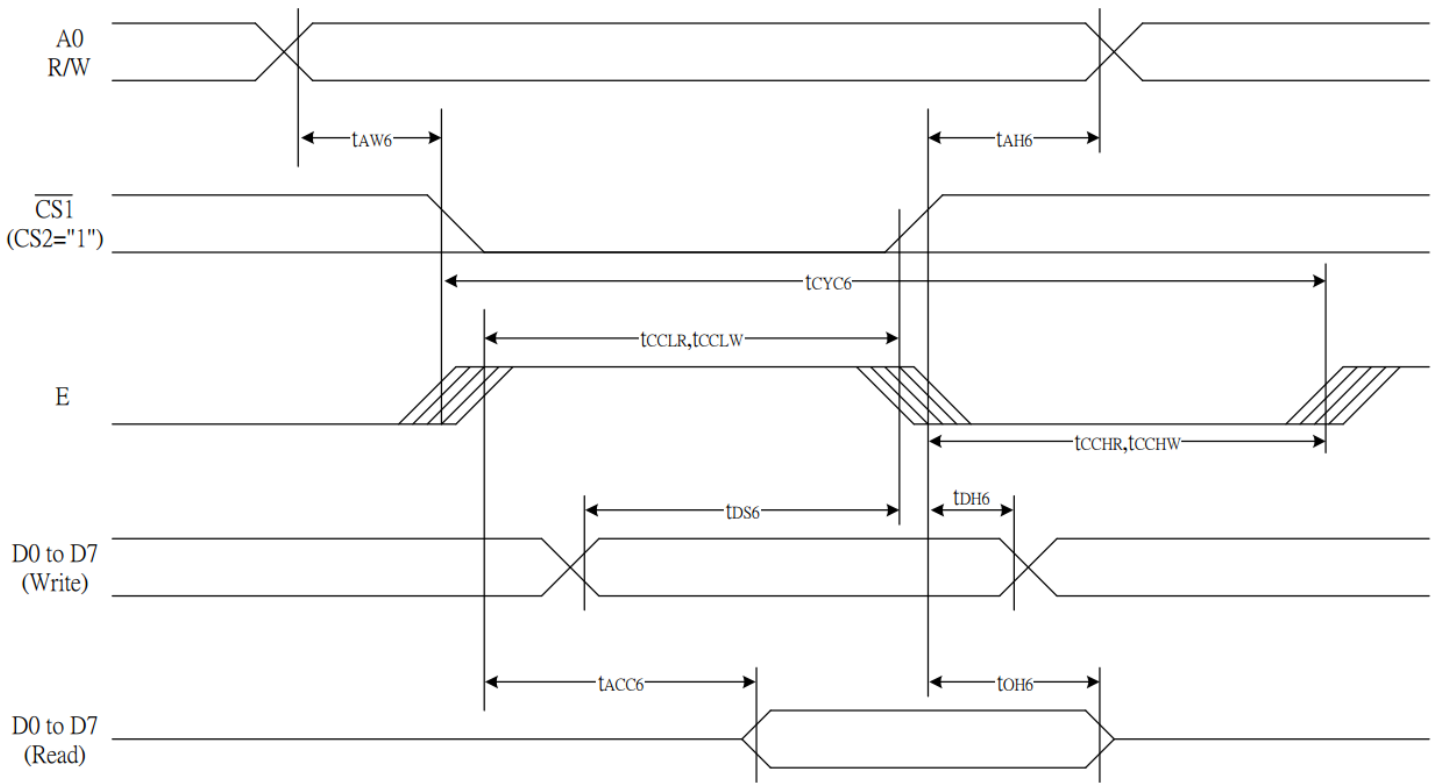

Item	Signal	Symbol	Condition	Rating		Units
				Min.	Max.	
Address hold time	A0	$t_{AH6}$		0	—	ns
Address setup time		$t_{AW6}$		0	—	
System cycle time		$t_{CYC6}$		240	—	
Enable L pulse width (WRITE)	WR	$t_{EWLW}$		80	—	
Enable H pulse width (WRITE)		$t_{EWHW}$		80	—	
Enable L pulse width (READ)	RD	$t_{EWLR}$		80	—	
Enable H pulse width (READ)		$t_{EWHR}$		140	—	
WRITE Data setup time	D0 to D7	$t_{DS6}$		40	—	
WRITE Address hold time		$t_{DH6}$		10	—	
READ access time		$t_{ACC6}$	$C_L = 100 \text{ pF}$	—	70	
READ Output disable time		$t_{OH6}$	$C_L = 100 \text{ pF}$	5	50	

## Serial Interface

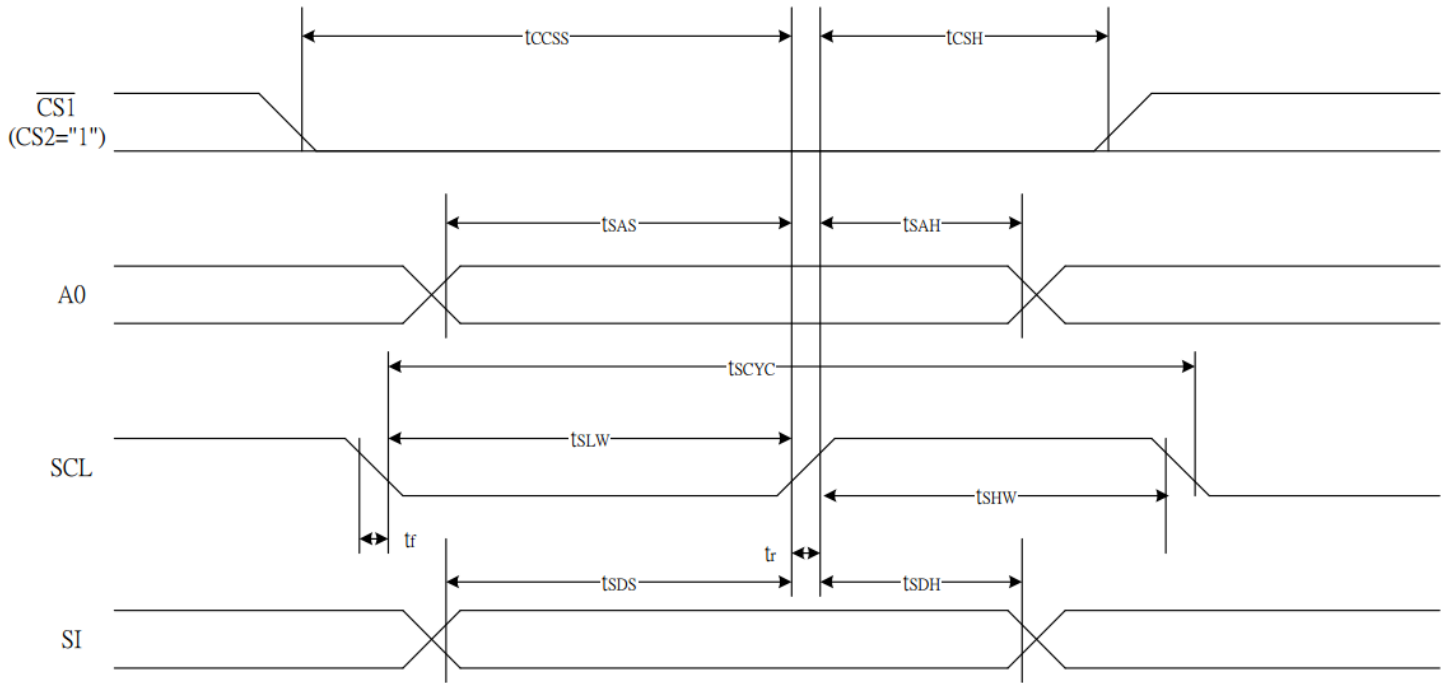

Item	Signal	Symbol	Condition	Rating		Units
				Min.	Max.	
Serial Clock Period	SCL	$T_{scyc}$		50	—	ns
SCL "H" pulse width		$T_{shw}$		25	—	
SCL "L" pulse width		$T_{slw}$		25	—	
Address setup time	A0	$T_{sas}$		20	—	
Address hold time		$T_{sah}$		10	—	
Data setup time	SI	$T_{sds}$		20	—	
Data hold time		$T_{sdh}$		10	—	
CS-SCL time	CS	$T_{css}$		20	—	
CS-SCL time		$T_{csh}$		40	—	

## Example Initialization Program

```
/******NHD-C24064WO*****  
void init()  
{  
    command_master(0xA2);           //1/9 bias  
    command_master(0xA0);           //ADC segment driver direction (A0=Normal)  
    command_master(0xC8);           //Com output reverse  
    command_master(0xA4);           //Display all points normal  
    command_master(0x40);           //Display Start line set  
    command_master(0x25);           //Internal resistor ratio  
    command_master(0x81);           //Electronic volume mode set  
    command_master(0x10);           //Electronic Volume  
    command_master(0x2F);           //Power controller set  
    command_master(0xAF);           //Display on  
  
    command_slave(0xA2);            //1/9 bias  
    command_slave(0xA0);            //ADC segment driver direction (A0=Normal)  
    command_slave(0xC8);            //Com output reverse  
    command_slave(0xA4);            //Display all points normal  
    command_slave(0x40);            //Display Start line set  
    command_slave(0x25);            //Internal resistor ratio  
    command_slave(0x81);            //Electronic volume mode set  
    command_slave(0x10);            //Electronic Volume  
    command_slave(0x2F);            //Power controller set  
    command_slave(0xAF);            //Display on  
}  
  
/******  
void command_master(unsigned int c)  
{  
    CS_Master = reset;  
    AO = reset;                       //Command   LOW  
    WRT = reset;  
    P1 = c;  
    delay(1);  
    WRT = set;  
    CS_Master = set;  
}  
  
/******  
void data_master(unsigned int d)  
{  
    CS_Master = reset;  
    AO = set;                           //Data       High  
    delay(1);  
    WRT = reset;  
    P1 = d;  
    delay(1);  
    WRT = set;  
    CS_Master = set;  
}  
/******
```

```
/******  
void commmand_slave(unsigned int c)  
{  
    CS_Slave = reset;  
    AO = reset;           //Command   LOW  
    WRT = reset;  
    P1 = c;  
    delay(1);  
    WRT = set;  
    CS_Slave = set;  
}  
  
/******  
void data_slave(unsigned int d)  
{  
    CS_Slave = reset;  
    AO = set;           //Data       High  
    delay(1);  
    WRT = reset;  
    P1 = d;  
    delay(1);  
    WRT = set;  
    CS_Slave = set;  
}  
  
/******
```

## Quality Information

Test Item	Content of Test	Test Condition	Note
High Temperature storage	Endurance test applying the high storage temperature for a long time.	+80°C , 200hrs	2
Low Temperature storage	Endurance test applying the low storage temperature for a long time.	-30°C , 200hrs	1,2
High Temperature Operation	Endurance test applying the electric stress (voltage & current) and the high thermal stress for a long time.	+70°C , 200hrs	2
Low Temperature Operation	Endurance test applying the electric stress (voltage & current) and the low thermal stress for a long time.	-20°C , 200hrs	1,2
High Temperature / Humidity Operation	Endurance test applying the electric stress (voltage & current) and the high thermal with high humidity stress for a long time.	+60°C , 90% RH , 96hrs	1,2
Thermal Shock resistance	Endurance test applying the electric stress (voltage & current) during a cycle of low and high thermal stress.	-20°C ← 25°C → 70°C 30min ← 5min → 30min = 1 cycle For 10 cycles	
Vibration test	Endurance test applying vibration to simulate transportation and use.	10-55Hz, 1.5mm amplitude. 60 sec in each of 3 directions X,Y,Z For 15 minutes	3
Static electricity test	Endurance test applying electric static discharge.	VS=800V, RS=330Ω, CS=150pF 10 times	

**Note 1:** No condensation to be observed.

**Note 2:** Conducted after 4 hours of storage at 25°C, 0%RH.

**Note 3:** Test performed on product itself, not inside a container.

## Precautions for using LCDs/LCMs

See Precautions at [www.newhavendisplay.com/specs/precautions.pdf](http://www.newhavendisplay.com/specs/precautions.pdf)

## Warranty Information and Terms & Conditions

[http://www.newhavendisplay.com/index.php?main\\_page=terms](http://www.newhavendisplay.com/index.php?main_page=terms)

# Mouser Electronics

Authorized Distributor

Click to View Pricing, Inventory, Delivery & Lifecycle Information:

[Newhaven Display:](#)

[NHD-C24064WO-ATFH#-3V3](#)