

ISL8225MEVAL2Z

User's Manual: Evaluation Board

Industrial Analog and Power

All information contained in these materials, including products and product specifications, represents information on the product at the time of publication and is subject to change by Renesas Electronics Corp. without notice. Please review the latest information published by Renesas Electronics Corp. through various means, including the Renesas Electronics Corp. website (<http://www.renesas.com>).

ISL8225MEVAL2Z

Evaluation Board

The [ISL8225M](#) is a complete, dual step-down switching mode DC/DC module. The dual outputs can easily be paralleled for single-output, high-current use. It is easy to apply this high-power, current-sharing DC/DC power module to power-hungry datacom, telecom, and FPGA applications. All that is needed to have a complete, dual 15A design ready for use are the ISL8225M, a few passive components, and V_{OUT} setting resistors.

The ease of use virtually eliminates design and manufacturing risks while dramatically improving time to market. If more output current is needed, parallel up to six ISL8225M modules to scale up to a 180A solution.

The ISL8225M has a thermally enhanced, compact QFN package that operates at full load and over-temperature without requiring forced-air cooling. Easy access to all pins, with few external components, reduces PCB design to a component layer and a simple ground layer.

The ISL8225MEVAL2Z evaluation board allows for a single 6-phase paralleled output, which delivers high current up to 90A. The input voltage is 4.5V to 20V and the default output voltage is set at 1.2V. The current level is 90A with no extra cooling required.

Key Features

- Up to 300W output for 3 modules in parallel operation
- Up to 90A load capability for 3 modules in parallel operation
- 4.5V to 20V input range
- 0.6V to 5.5V output range
- 1.5% output voltage accuracy
- Up to 95% conversion efficiency
- Lower output ripple and input ripple due to multiple phases interleave

Specifications

This board is configured and optimized for the following operating conditions:

- V_{IN} = 4.5V to 20V
- V_O = 1.2V
- I_O = 90A
- f_{SW} = 500kHz

Ordering Information

Part Number	Description
ISL8225MEVAL2Z	6-Phase, 90A Evaluation Board

Related Literature

For a full list of related documents, visit our website:

- [ISL8225M](#) device page

Related Resources

- Evaluation Board [Video](#)

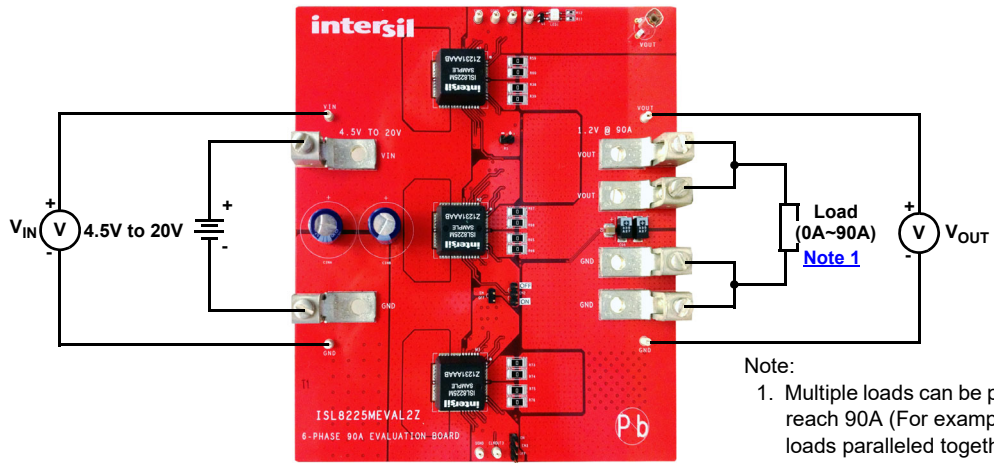

Figure 1. ISL8225MEVAL2Z Board Image

1. Functional Description

1.1 Recommended Equipment

- 0V to 20V power supply with at least 10A source current capability
- Electronic load capable of sinking current up to 90A (multiple electronic current loads can be used in parallel to sink more current)
- Digital Multimeters (DMMs)
- 100MHz quad-trace oscilloscope

1.2 Quick Start

The inputs are J3 (VIN) and J4 (GND). The outputs are J1 and J5 (VOUT), J2 and J6 (GND), and J6 (VOUT2). See [Figure 1](#). This 90A evaluation board can be easily modified to 30A (one module) or 60A (two modules) operation.

1. Connect a power supply capable of sourcing at least 10A to the input (VIN J3 and GND J4) of the ISL8225MEVAL2Z, with a voltage between 4.5V to 20V. Connect an electronic load or the device to be powered to the output (VOUT (J1, J5) and GND (J2, J6)) of the board. All connections, especially the low voltage, high current V_{OUT} lines, should be able to carry the desired load current and should be made as short as possible. Duplicate tab connections on VOUT (J1, J5) and GND (J2, J6) to carry large current.
2. Ensure the jumpers for EN2 and EN3 are in the “ON” position and EN is open. Turn on the power supply. If the board is working properly, the green LED illuminates; if not, the red LED illuminates (recheck the wire/jumper connections in this case). Measure the output voltage, V_{OUT}, which should be at 1.2V.
3. The ISL8225MEVAL2Z is manufactured with a V_{OUT} default value of 1.2V; if different output voltages are needed, board resistors can be exchanged to provide the desired V_{OUT}. See [Table 1 on page 4](#) for R2/R64 resistor values, which can be used to produce different output voltages.

For 12V V_{IN} and V_{OUT} more than 1.5V, the switching frequency needs to be adjusted, as shown in [Table 1](#). The resistor R_{FSET} can be adjusted for the desired frequency. No frequency adjustments are necessary for V_{OUT} below 1.5V. For 5V V_{IN}, the frequency does not need to be adjusted and the module default frequency can be used at any allowed V_{OUT}. If the output voltage is set to more than 1.8V, the output current needs to be derated to allow for safe operation. See the derating curves in the [ISL8225M](#) datasheet.

Table 1. Value of Bottom Resistor for Different Output Voltages (R1 = 1k)

V _{OUT} (V)	R2 /R64 (Ω)	Frequency (kHz)	R _{FSET} (Ω) (V _{IN} = 12V)
0.6	0/0	Default	Default
0.8	3010/1500	Default	Default
1.0	1500750	Default	Default
1.2	1000/500	Default	Default
1.5	665/332	Default	Default
2.5	316/158	650	249k
3.3	221/110	800	124k
5.0	137/68.1	950	82.5k
5.5	121/60.4	950	82.5k

1.3 Board Setting

If low current applications are needed, this 90A evaluation board can be easily programmed to 30A and 60A use.

1.3.1 30A Application (1 Module)

- EN -- Open, EN2-- OFF, EN3 -- OFF

In this mode, only module 1 is running and modules 2 and 3 are disabled.

1.3.2 60A Application (2 Modules)

- EN -- Open, EN2-- ON, EN3 -- OFF
- EN -- Open, EN2-- OFF, EN3 -- ON

In this mode, only modules 1 and 2 (or 3) are running and module 3 (or 2) is disabled.

1.3.3 90A Application (3 Modules)

- EN -- Open, EN2-- ON, EN3 -- ON

In this mode, all modules are running.

1.3.4 Disable All Modules and Use the EN Pin to Start the Modules

EN -- Connected

In this mode, all modules are disabled and EN can be used to control all modules to startup.

1.4 Evaluation Board Information

The evaluation board size is 150mm x 130mm. It is a 6-layer board, containing 2 oz. copper on the top and bottom layers and 1 oz. copper on all internal layers. The board can be used as a 90A reference design. See "[Board Layout](#)" on page 10. The board is made of FR4 material and all components, including the solder attachment, are Pb-free.

1.4.1 Current Sharing Check

The evaluation board allows you to measure the current sharing accuracy. Four 0Ω resistors (such as R59~R62 for M1 Channel 2 in [Figure 2](#)) are put serially on each output with two on each side of the evaluation board. To measure the output current of each phase, remove all four resistors and put looped wires or sensing resistors on correct positions.

Although the assembled resistors have zero resistance, there is still small resistance (< 50mΩ) on each resistor. At large output current, the efficiency can be decreased by 1~3% due to the power loss on those 0Ω resistors. The efficiency curves are shown in [Figures 16](#) and [17](#) with 0Ω resistors, while [Figures 18](#) and [19](#) show the efficiency curves by replacing those resistors with short copper straps.

1.4.2 Thermal Considerations and Current Derating

For high current applications, board layout is very critical to make the module operate safely and deliver maximum allowable power. To carry large currents, the board layout needs to be designed carefully to maximize thermal performance. To achieve this, select enough trace width, copper weight, and the proper connectors.

This evaluation board is designed for running 90A at 1.2V at room temperature without additional cooling systems needed. However, if the output voltage is increased or the board is operated at elevated temperatures, the available current is derated. See the derated current curves in the [ISL8225M](#) datasheet to determine the output current available.

For layout of designs using the ISL8225M, the thermal performance can be improved by adhering to the following design tips:

1. Use the top and bottom layers to carry the large current. VOUT1, VOUT2, Phase 1, Phase 2, PGND, VIN1, and VIN2 should have large, solid planes. Place enough thermal vias to connect the power planes in different layers under and around the module.

- Phase 1 and Phase 2 pads are switching nodes that generate switching noise. Keep these pads under the module. For noise-sensitive applications, Renesas recommends keeping phase pads only on the top and inner layers of the PCB; do not place phase pads exposed to the outside on the bottom layer of the PCB. To improve the thermal performance, the phase pads can be extended in the inner layer, as shown in Phase 1 and 2 pads on layer 3 (Figure 11) for this 90A evaluation board. Make sure that layer 2 and layer 4 have the GND layers to cover the extended areas of phase pads at layer 3 to avoid noise coupling.
- To avoid noise coupling, Renesas recommends adding 1nF capacitors on all COMP and ISHARE pins of each module for multiple module operations.
- Place the modules evenly on the board and leave enough space between modules. If the board space is limited, try to put the modules with low power loss closely together (such as low V_{OUT} or I_{OUT}) while still separating the module with high power loss.
- If the ambient temperature is high or the board space is limited, airflow is needed to dissipate more heat from the modules. A heat sink can also be applied to the top side of the module to further improve the thermal performance (heat sink recommendation: Aavid Thermalloy, part number 375424B00034G, www.aavid.com).

1.4.3 Remote Sensing

The ISL8225MEVAL2Z board allows you to apply the remote sensing function to loads to achieve good output regulation accuracy. To make use of this function, remove resistors R7 and R8 and connect the Kelvin sensing lines through the jumper JP4 (RS) to the point of load.

1.4.4 Phase-Shift Programming

In current sharing mode, the phase-shift is needed to interleave the different phases to lower the input and output ripples. As shown in Table 2, there are different sharing modes from 2-phase (180° phase-shift) and 4-phase (90° phase-shift) to 6-phase (60° phase-shift). The master module sends the CLKOUT signal to the SYNC pin of the second module with the phase-shift to its own clock signal. Then the second module synchronizes to the CLKOUT signal of the master module and sends its CLKOUT signal to the third module's SYNC pin. The individual 2 phases of each module are set as a 180° phase-shift by default. This evaluation board is set to mode 5B with 60° phase-shift between phases.

If the MODE pin is not tied to VCC (5A or 5B), all VMON pins of different modules can be tied together, except the VMON pin of the master phase. If mode 7A is needed to allow for 90° phase-shift, the MODE pin has to tie to VCC. In this case, the VMON pin of the associated module needs to be separated by connecting a 953Ω resistor and a 22nF capacitor to SGND, as shown in the [ISL8225M](#) datasheet.

Table 2. ISL8225M 3-Module Board Operation Modes

1st Module (I = Input; O = Output; I/O = Input and Output, Bi-Direction)									Modes of Operation		Output
Mode	EN2 (I)	EN3 (I)	VSEN2 - (I)	Mode (I)	VSEN2 + (I)	CLKOUT/REFIN WRT 1st (I OR O)	ISHARE (I/O) Represents Which Channel(S) Current	2nd Channel WRT 1 ST (O)	Operation Mode of 2nd Module	Operation Mode of 3rd Module	
5A	0	0	V _{CC}	GND	-	60°	Both Channels	180°	-	-	2-Phase
5B	1	1	V _{CC}	GND	-	60°	Both Channels	180°	5B	5B	6-Phase
7A	1	0	V _{CC}	V _{CC}	V _{CC}	90°	Both Channels	180°	5A or 7A	-	4-Phase
8	Cascaded Module Operation MODEs 5A+5A+7A+5A+5A+5A/7A, No External Clock Required										12-Phase

2. PCB Layout Guidelines

2.1 ISL8225MEVAL2Z Board Schematics

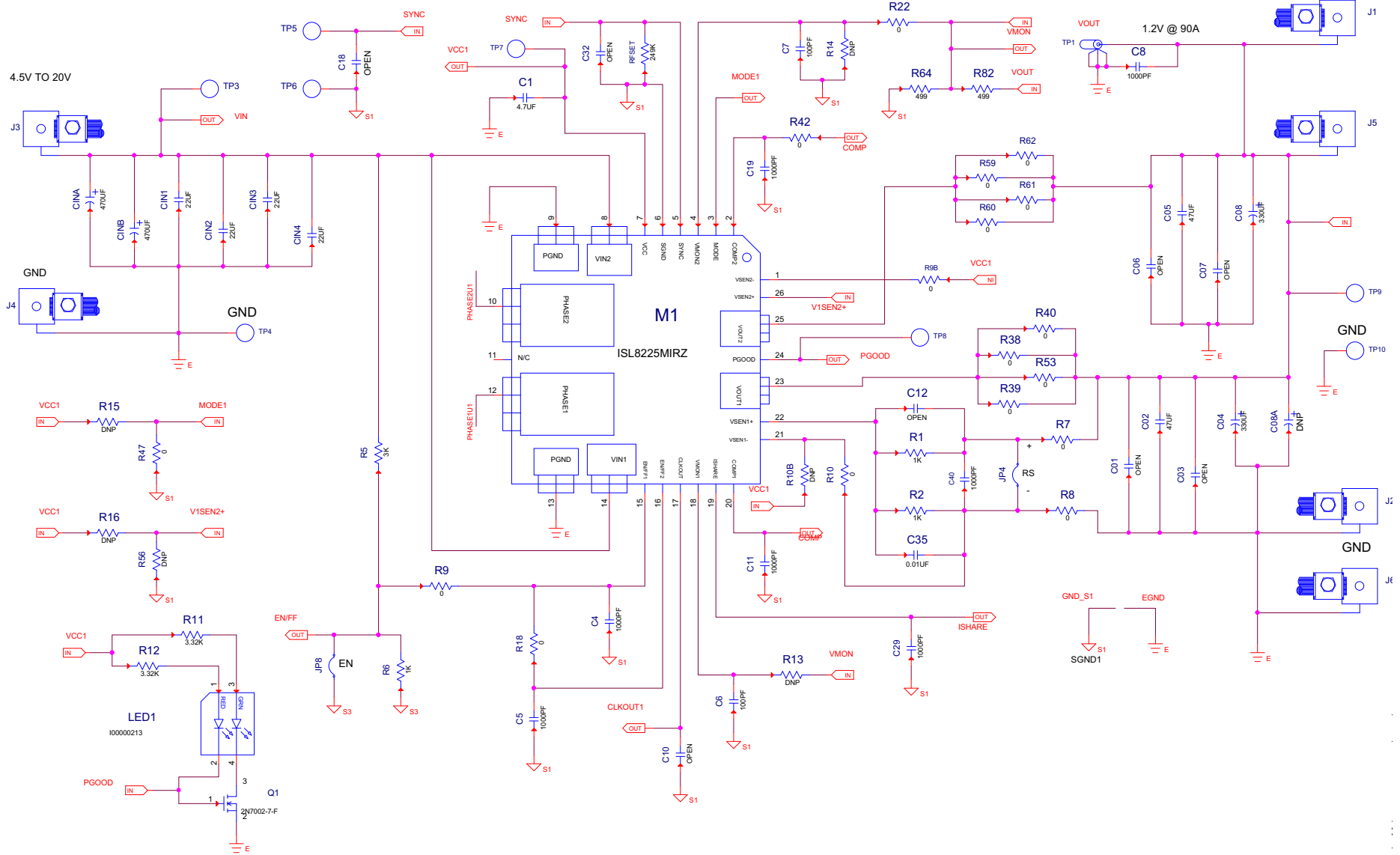

Figure 2. ISL8225MEVAL2Z Board Schematic

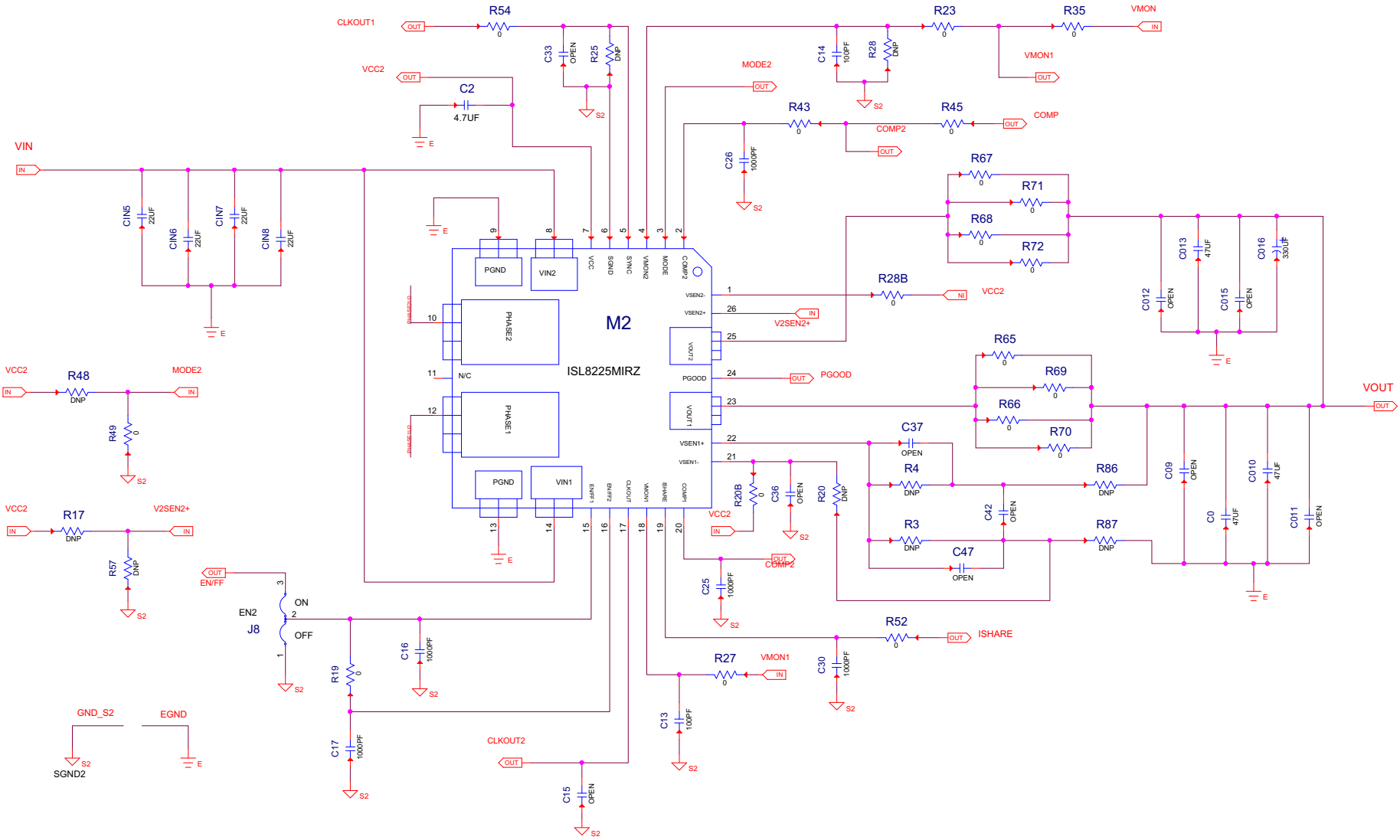

Figure 3. ISL8225MEVAL2Z Board Schematic

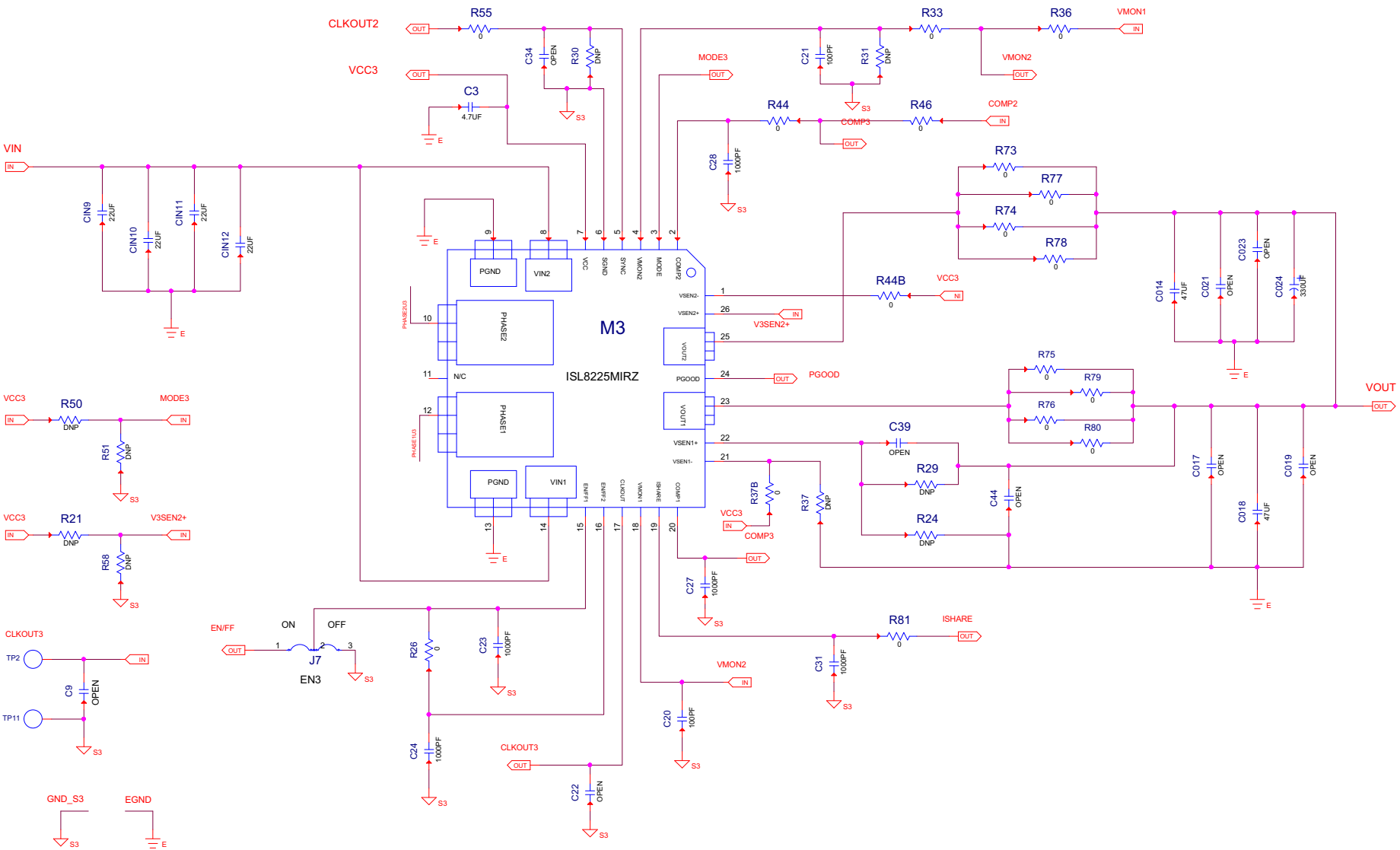

Figure 4. ISL8225MEVAL2Z Board Schematic

2.2 Board Layout

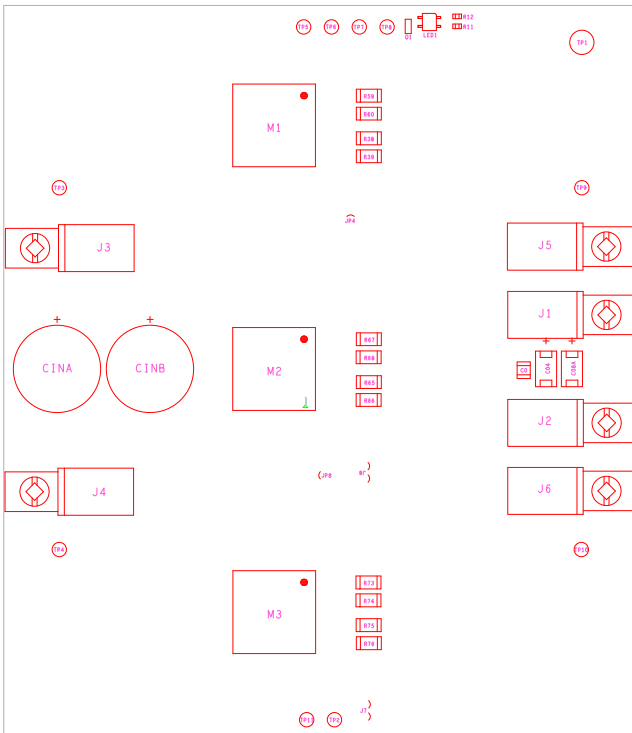

Figure 5. Top Assembly

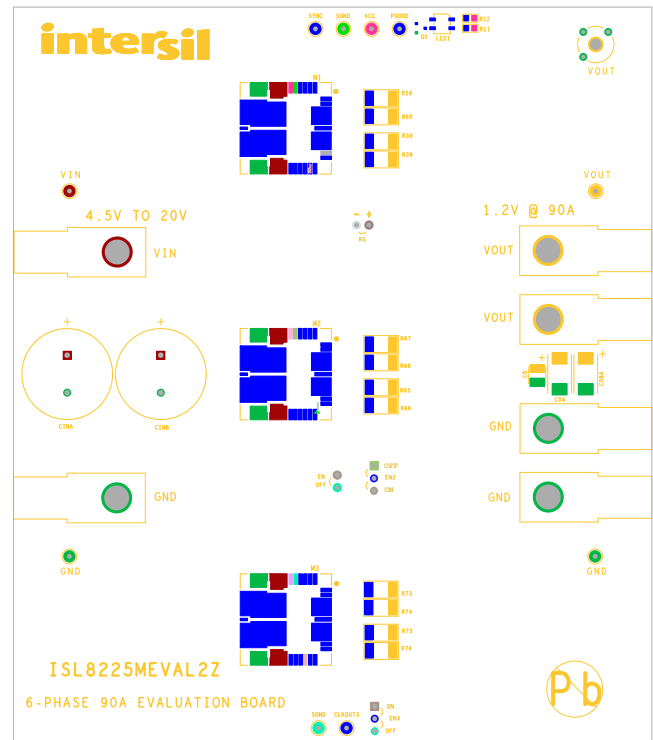

Figure 6. Top Silk Screen

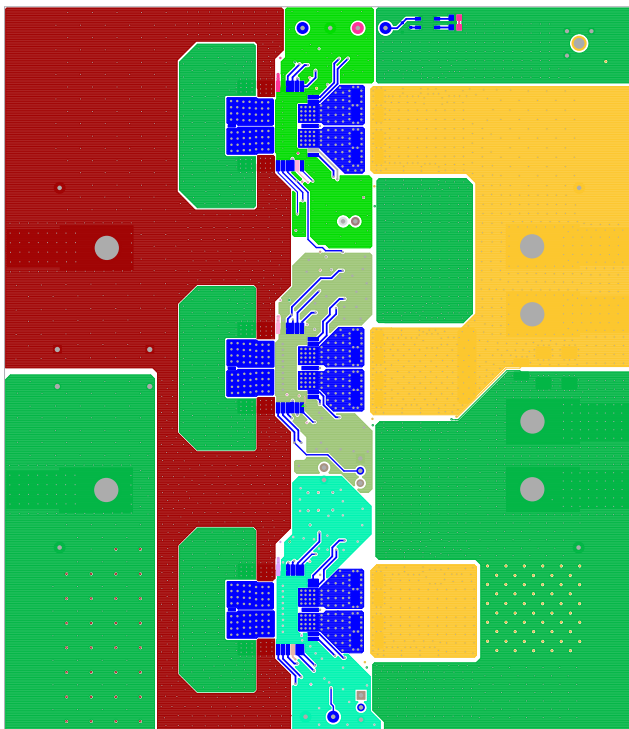

Figure 7. Top Layer Component Side

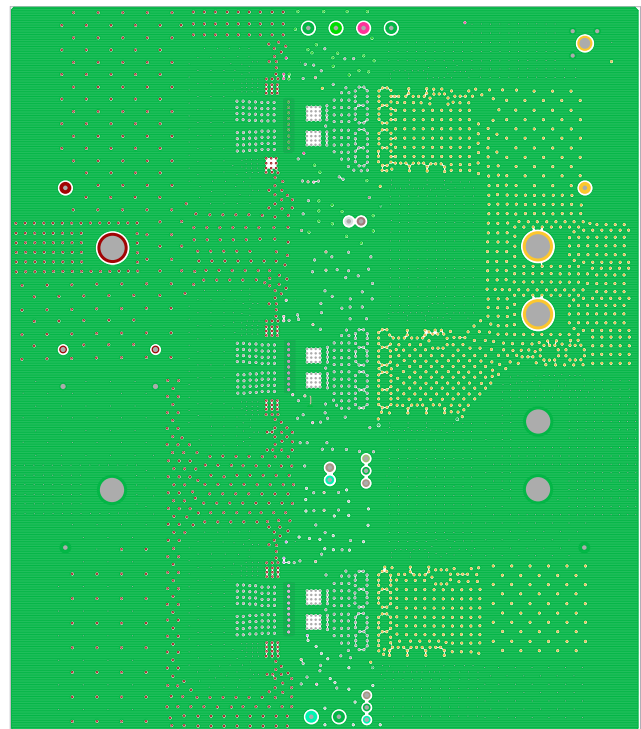

Figure 8. Layer 2

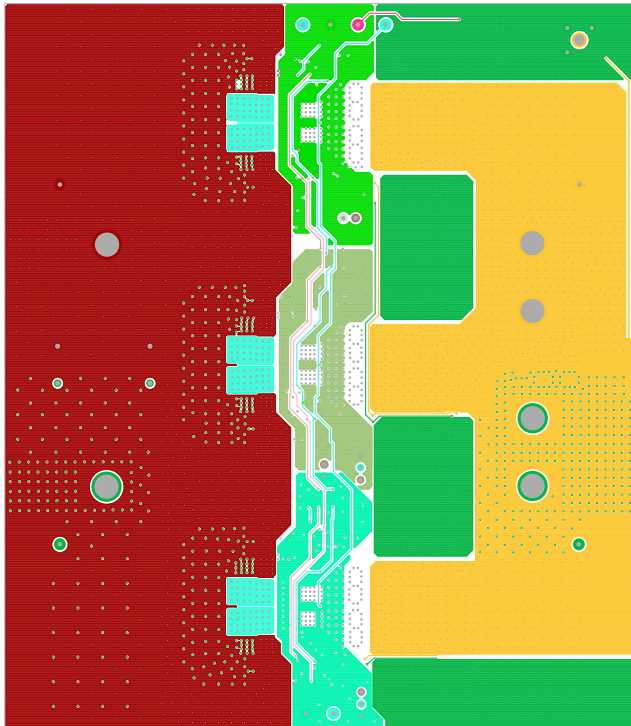

Figure 9. Layer 3

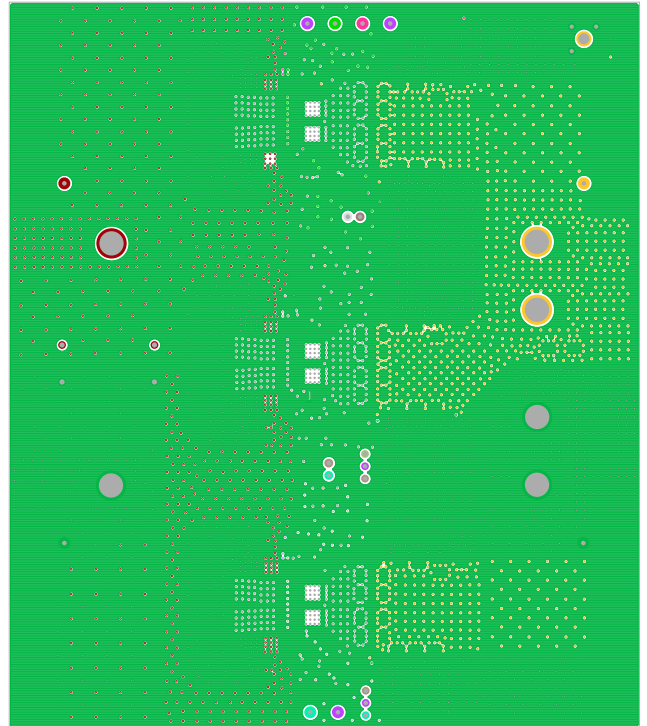

Figure 10. Layer 4

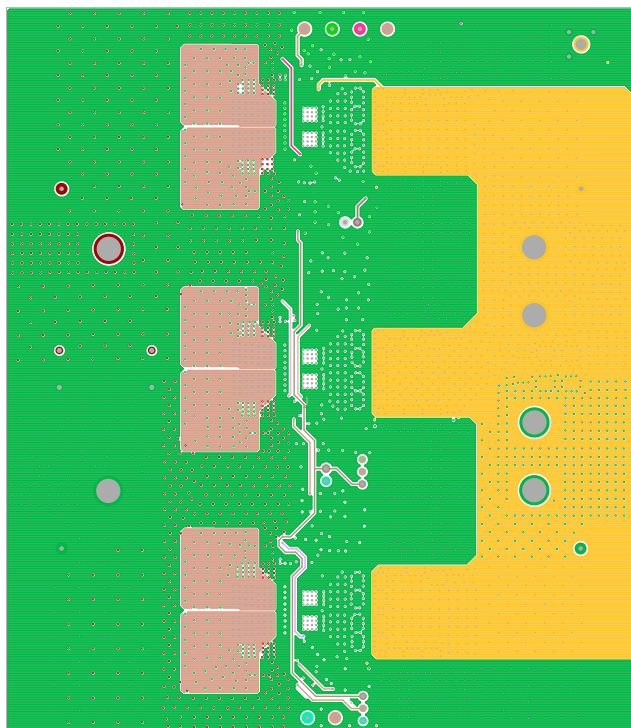

Figure 11. Layer 5

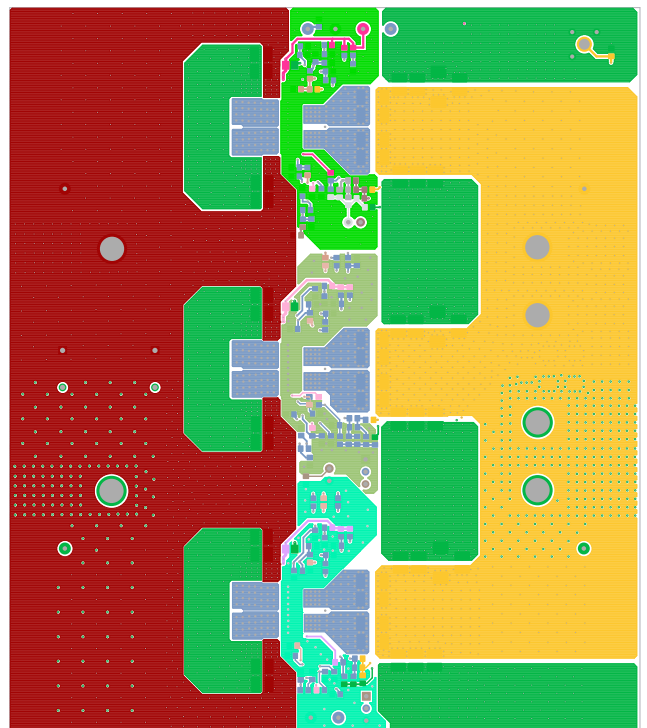

Figure 12. Bottom Layer Solder Side

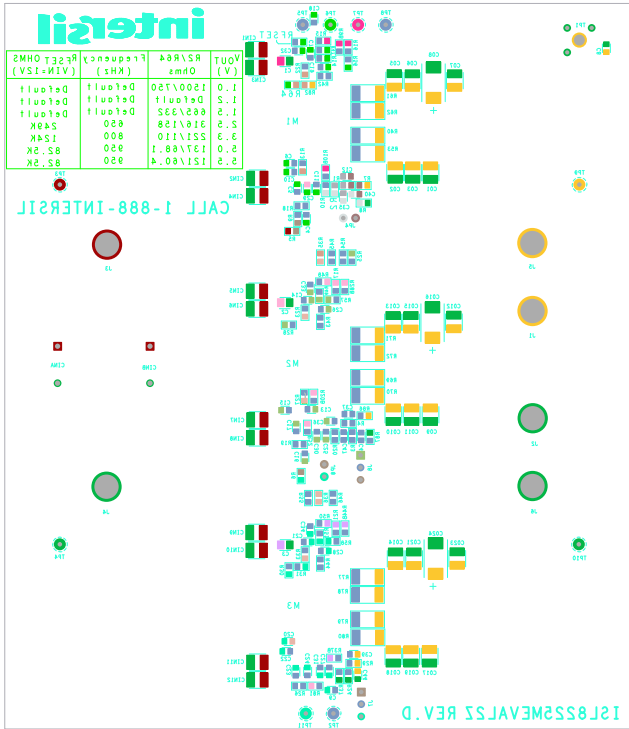

Figure 13. Bottom Silk Screen

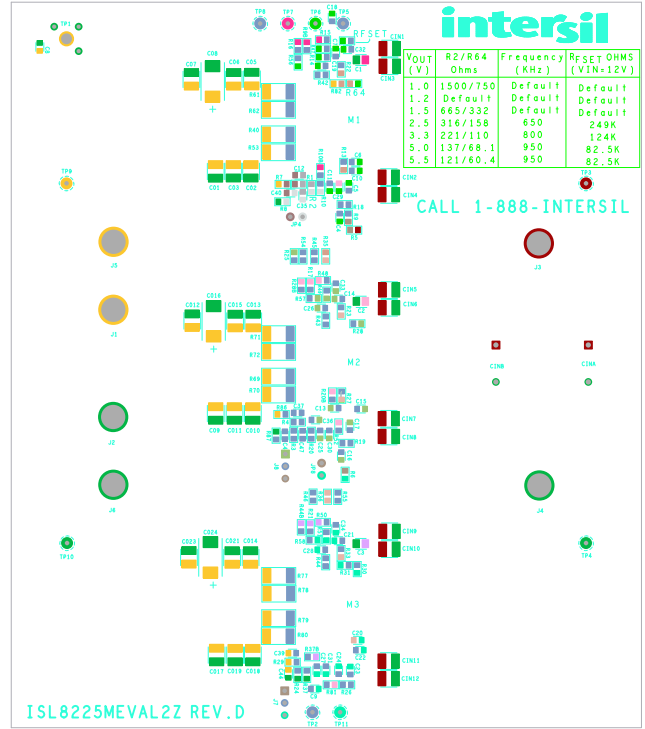

Figure 14. Bottom Silk Screen Mirrored

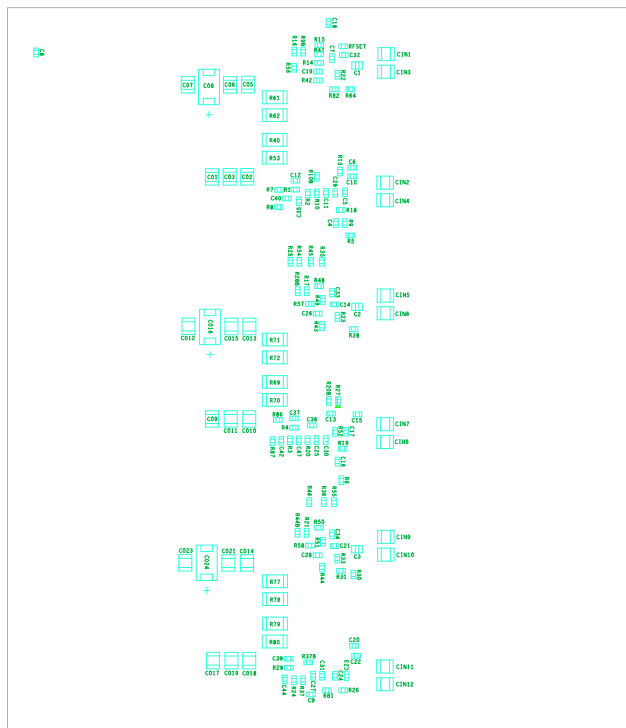

Figure 15. Bottom Assembly

2.3 Bill of Materials

Part Number	Ref Des	Qty.	Value	Tol.	Voltage	Power	Package Type	JEDEC Type	Manufacturer	Description
10TPB330M	C04, C08, C016, C024, C08A	5	330 μ F	20%	10V		SMD	CAP_7343_149	SANYO-POSCAP	Standard solid electrolytic chip tantalum SMD capacitor
131-4353-00	TP1	1					CONN	TEK131-4353-00	Tektronix	Scope probe test point PCB mount
2N7002-7-F	Q1	1					SOT23	SOT23	Fairchild	N-Channel EMF effect transistor (Pb-free)
5002	TP2-TP11	10					THOLE	MTP500X	Keystone	Miniature white test point 0.100 pad 0.040 Thole
ECA-1VM471	CINA, CINB	2	470 μ F	20%	35V		RADIAL	CAPR_708X1398_300_P	Panasonic	Radial capacitor Pb-free
GRM21BR71C475KA73L	C1-C3	3	4.7 μ F	10%	16V		805	CAP_0805	Murata	Ceramic capacitor
GRM32ER70A476K	C0, C02, C05, C010, C013, C014, C018	7	47 μ F	10%	10V		1210	CAP_1210	Murata	Ceramic chip capacitor
GRM32ER71E226KE15L	CIN1-CIN12	12	22 μ F	10%	25V		1210	CAP_1210	Murata	Ceramic chip capacitor
H1045-00101-50V10	C6, C7, C13, C14, C20, C21	6	100pF	10%	50V		603	CAP_0603	Generic	Multilayer capacitor
H1045-00102-16V10	C8	1	1000pF	10%	16V		603	CAP_0603	Generic	Multilayer capacitor
H1045-00102-50V10	C4, C5, C9, C11, C16-C19, C23-C31, C40	18	1000pF	10%	50V		603	CAP_0603	Generic	Multilayer capacitor
H1045-00103-50V10	C35	1	0.01 μ F	10%	50V		603	CAP_0603	Generic	Multilayer capacitor
H1045-OPEN	C10, C12, C15, C22, C32-C34, C36, C37, C39, C42, C44, C47	13	OPEN	5%	OPEN		603	CAP_0603	Generic	Multilayer capacitor
H1082-OPEN	C01, C03, C06, C07, C09, C011, C012, C015, C017, C019, C021, C023	12	OPEN	10%	OPEN		1210	CAP_1210	Generic	Ceramic chip capacitor
H2505-DNP-DNP-1	R3, R4, R13-R17, R20, R21, R24, R25, R28-R31, R37, R48, R50, R51, R56-R58, R86, R87, R10B, RFSET	26	DNP	1%		DNP	603	RES_0603	Generic	Metal film chip resistor (do not populate)

Part Number	Ref Des	Qty.	Value	Tol.	Voltage	Power	Package Type	JEDEC Type	Manufacturer	Description
H2511-00R00-1/16W1	R7-R10, R18, R19, R22, R23, R26, R27, R33, R35, R36, R42-R47, R49, R52, R54, R55, R81, R9B, R20B, R28B, R37B, R44B	29	0Ω	1%		1/16W	603	RES_0603	Generic	Thick film chip resistor
H2511-01001-1/16W1	R1, R2, R6	3	1kΩ	1%		1/16W	603	RES_0603	Generic	Thick film chip resistor
H2511-03321-1/16W1	R11, R12	2	3.32kΩ	1%		1/16W	603	RES_0603	Generic	Thick film chip resistor
H2511-04990-1/16W1	R64, R82	2	499Ω	1%		1/16W	603	RES_0603	Generic	Thick film chip resistor
H2520-00R00-1/2W5	R38-R40, R53, R59-R62, R65-R80	24	0Ω	5%		1/2W	2010	RES_2010	Generic	Thick film chip resistor
ISL8225MIRZ	M1-M3	3					QFN	QFN26_670X670_ISL8225M	Intersil	Dual 15A DC/DC power module
JUMPER-3-100	J7, J8	2					THOLE	JUMPER-3	Generic	Three pin jumper
JUMPER2_100	JP4, JP8	2					THOLE	JUMPER-1	Generic	Two pin jumper
KPA8CTP	J1-J6	6					CONN	KPA8CTP	Burndy	Wire connector lug
MCR03EZPFX3001	R5	1	3kΩ	1%		1/10W	603	RES_0603	ROHM	Metal film chip resistor
SSL-LXA3025IGC	LED1	1					SMD	LED_3X2_5MM	Lumex	3mmx2.5mm surface mount red/green LED

Note:

- Resistance accuracy of the feedback resistor divider R1/R2 can affect the output voltage accuracy. Please use high accuracy resistance (0.5% or 0.1%) to meet the output accuracy requirement.

3. ISL8225MEVAL2Z Efficiency Curves

3.1 Efficiency Curves with 0Ω Resistance on the Output

Test conditions at +25°C and no air flow.

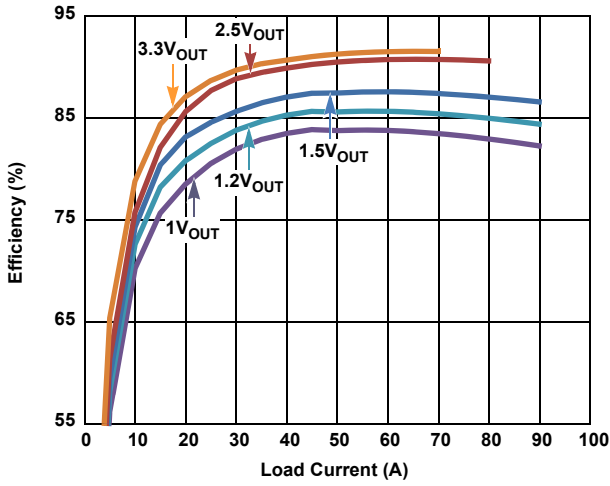

Figure 16. 12V Input

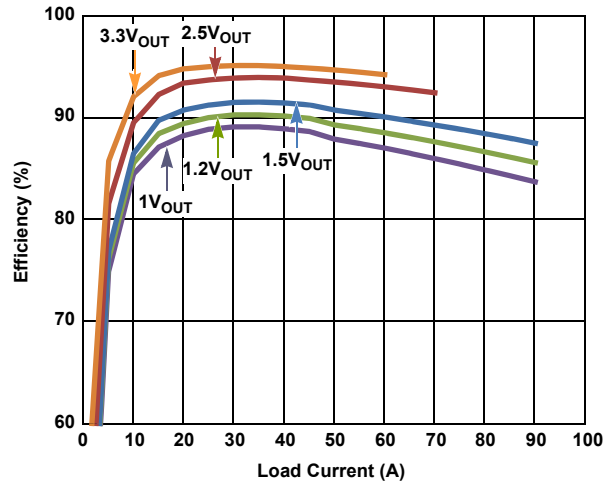

Figure 17. 5V Input

3.2 Efficiency Curves by Replacing 0Ω Resistance with Thick Copper Strap

Test conditions at +25°C and no air flow.

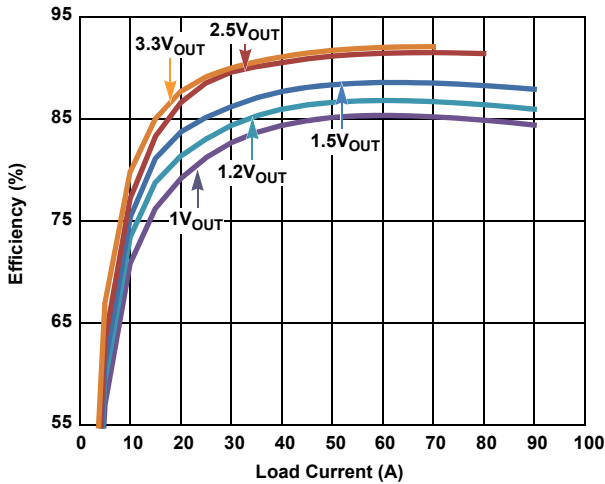

Figure 18. 12V Input

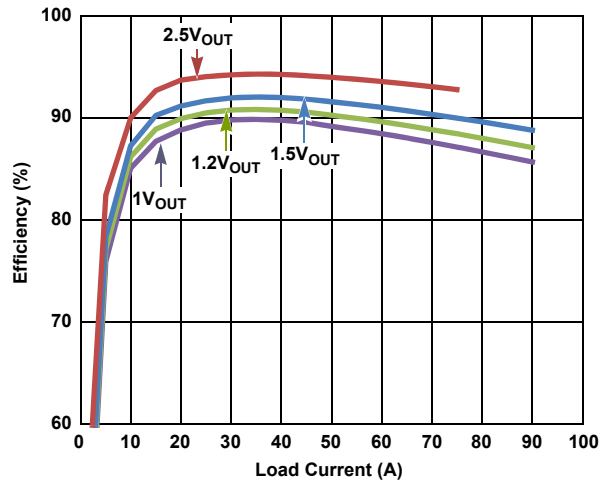

Figure 19. 5V Input

4. Revision History

Rev.	Date	Description
2.00	Jun.25.19	Applied new formatting throughout. Replaced QR code with link to video on page 1. Updated Schematics with Orchard version. Added Revision History section.

Notice

1. Descriptions of circuits, software and other related information in this document are provided only to illustrate the operation of semiconductor products and application examples. You are fully responsible for the incorporation or any other use of the circuits, software, and information in the design of your product or system. Renesas Electronics disclaims any and all liability for any losses and damages incurred by you or third parties arising from the use of these circuits, software, or information.
2. Renesas Electronics hereby expressly disclaims any warranties against and liability for infringement or any other claims involving patents, copyrights, or other intellectual property rights of third parties, by or arising from the use of Renesas Electronics products or technical information described in this document, including but not limited to, the product data, drawings, charts, programs, algorithms, and application examples.
3. No license, express, implied or otherwise, is granted hereby under any patents, copyrights or other intellectual property rights of Renesas Electronics or others.
4. You shall not alter, modify, copy, or reverse engineer any Renesas Electronics product, whether in whole or in part. Renesas Electronics disclaims any and all liability for any losses or damages incurred by you or third parties arising from such alteration, modification, copying or reverse engineering.
5. Renesas Electronics products are classified according to the following two quality grades: "Standard" and "High Quality". The intended applications for each Renesas Electronics product depends on the product's quality grade, as indicated below.
 - "Standard": Computers; office equipment; communications equipment; test and measurement equipment; audio and visual equipment; home electronic appliances; machine tools; personal electronic equipment; industrial robots; etc.
 - "High Quality": Transportation equipment (automobiles, trains, ships, etc.); traffic control (traffic lights); large-scale communication equipment; key financial terminal systems; safety control equipment; etc.Unless expressly designated as a high reliability product or a product for harsh environments in a Renesas Electronics data sheet or other Renesas Electronics document, Renesas Electronics products are not intended or authorized for use in products or systems that may pose a direct threat to human life or bodily injury (artificial life support devices or systems; surgical implantations; etc.), or may cause serious property damage (space system; undersea repeaters; nuclear power control systems; aircraft control systems; key plant systems; military equipment; etc.). Renesas Electronics disclaims any and all liability for any damages or losses incurred by you or any third parties arising from the use of any Renesas Electronics product that is inconsistent with any Renesas Electronics data sheet, user's manual or other Renesas Electronics document.
6. When using Renesas Electronics products, refer to the latest product information (data sheets, user's manuals, application notes, "General Notes for Handling and Using Semiconductor Devices" in the reliability handbook, etc.), and ensure that usage conditions are within the ranges specified by Renesas Electronics with respect to maximum ratings, operating power supply voltage range, heat dissipation characteristics, installation, etc. Renesas Electronics disclaims any and all liability for any malfunctions, failure or accident arising out of the use of Renesas Electronics products outside of such specified ranges.
7. Although Renesas Electronics endeavors to improve the quality and reliability of Renesas Electronics products, semiconductor products have specific characteristics, such as the occurrence of failure at a certain rate and malfunctions under certain use conditions. Unless designated as a high reliability product or a product for harsh environments in a Renesas Electronics data sheet or other Renesas Electronics document, Renesas Electronics products are not subject to radiation resistance design. You are responsible for implementing safety measures to guard against the possibility of bodily injury, injury or damage caused by fire, and/or danger to the public in the event of a failure or malfunction of Renesas Electronics products, such as safety design for hardware and software, including but not limited to redundancy, fire control and malfunction prevention, appropriate treatment for aging degradation or any other appropriate measures. Because the evaluation of microcomputer software alone is very difficult and impractical, you are responsible for evaluating the safety of the final products or systems manufactured by you.
8. Please contact a Renesas Electronics sales office for details as to environmental matters such as the environmental compatibility of each Renesas Electronics product. You are responsible for carefully and sufficiently investigating applicable laws and regulations that regulate the inclusion or use of controlled substances, including without limitation, the EU RoHS Directive, and using Renesas Electronics products in compliance with all these applicable laws and regulations. Renesas Electronics disclaims any and all liability for damages or losses occurring as a result of your noncompliance with applicable laws and regulations.
9. Renesas Electronics products and technologies shall not be used for or incorporated into any products or systems whose manufacture, use, or sale is prohibited under any applicable domestic or foreign laws or regulations. You shall comply with any applicable export control laws and regulations promulgated and administered by the governments of any countries asserting jurisdiction over the parties or transactions.
10. It is the responsibility of the buyer or distributor of Renesas Electronics products, or any other party who distributes, disposes of, or otherwise sells or transfers the product to a third party, to notify such third party in advance of the contents and conditions set forth in this document.
11. This document shall not be reprinted, reproduced or duplicated in any form, in whole or in part, without prior written consent of Renesas Electronics.
12. Please contact a Renesas Electronics sales office if you have any questions regarding the information contained in this document or Renesas Electronics products.

(Note1) "Renesas Electronics" as used in this document means Renesas Electronics Corporation and also includes its directly or indirectly controlled subsidiaries.

(Note2) "Renesas Electronics product(s)" means any product developed or manufactured by or for Renesas Electronics.

(Rev.4.0-1 November 2017)

Corporate Headquarters

TOYOSU FORESIA, 3-2-24 Toyosu,
Koto-ku, Tokyo 135-0061, Japan
www.renesas.com

Contact Information

For further information on a product, technology, the most up-to-date version of a document, or your nearest sales office, please visit:
www.renesas.com/contact/

Trademarks

Renesas and the Renesas logo are trademarks of Renesas Electronics Corporation. All trademarks and registered trademarks are the property of their respective owners.

ISL8225MEVAL2Z