



Power-Source Selector for Dual-Battery Systems

MAX1538

General Description

The MAX1538 selector provides power-source control for dual-battery systems. The device selects between an AC adapter and dual batteries based on the presence of the three power sources and the state of charge of each battery. The MAX1538 includes analog comparators to detect AC/airline-adaptor presence and determine battery undervoltage. Fast analog circuitry allows the device to switch between power sources to implement a break-before-make time, which allows hot swapping of battery packs. The MAX1538 independently performs power-source monitoring and selection, freeing the system power-management μP for other tasks. This simplifies the development of μP power-management firmware and allows the μP to enter standby, reducing system power consumption.

The MAX1538 supports "relearn mode," which allows the system to measure and fully utilize battery capacity. In this state, the part allows the selected battery to be discharged even when an AC adapter is present. The MAX1538 can also be used to power the system in an aircraft. On detecting an airline adapter, the MAX1538 automatically disables charging or discharging of battery packs and only allows the system to be powered from the adapter.

The MAX1538 is available in a space-saving 28-pin thin QFN package with a maximum footprint of 5mm x 5mm.

Applications

Notebook and Subnotebook Computers
Internet Tablets
Dual-Battery Portable Equipment

Pin Configuration appears at end of data sheet.

Features

- ◆ Automatically Detects and Responds to Low-Battery Voltage Condition
- ◆ Battery Insertion and Removal
- ◆ AC-Adapter Presence
- ◆ Airline-Adapter Presence
- ◆ Step-Down and Step-Up Charger Compatibility
- ◆ Fast Break-Before-Make Selection
- ◆ Allows Hot Swapping of Power Sources
- ◆ No External Schottky Diodes Needed
- ◆ 50 μA Maximum Battery Quiescent Current
- ◆ Implements Battery Capacity Relearning
- ◆ Allows Usage of Aircraft Supply
- ◆ Direct Drive of P-Channel MOSFETs
- ◆ Simplifies Power-Management μP Firmware
- ◆ 4.75V to 28V AC-Adapter Input Voltage Range
- ◆ Small 28-Pin Thin QFN Package (5mm x 5mm)

Ordering Information

PART	TEMP RANGE	PIN-PACKAGE
MAX1538ETI	-40°C to +85°C	28 Thin QFN

Typical Operating Circuit

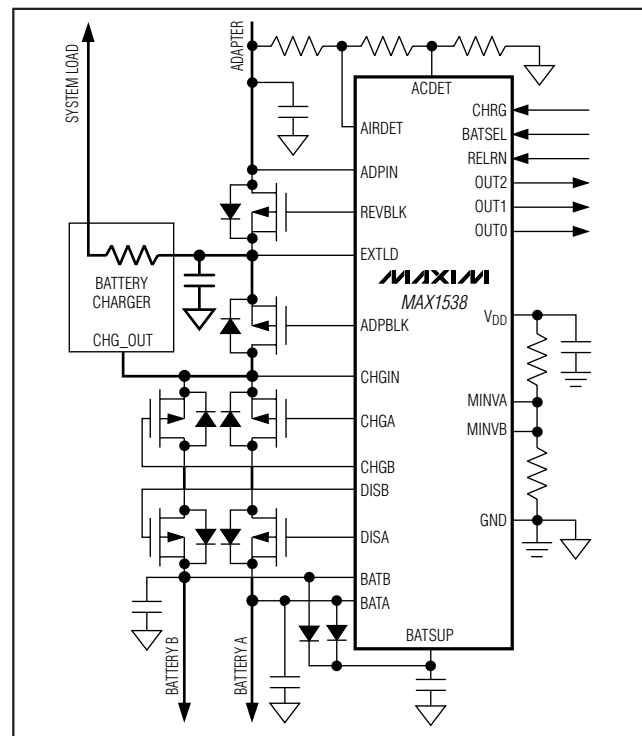

Power-Source Selector for Dual-Battery Systems

ABSOLUTE MAXIMUM RATINGS

VEXTLD, VBATSUP, VADPIN, VBATA, VBATB, VCHGIN to GND	-0.3V to +30V
VADPPWR to GND	-0.3V to (VADPIN + 0.3V)
VREVLK, VADPBLK to GND	-0.3V to (VEXTLD + 0.3V)
VCHGA, VCHGB, VDISBAT to GND	-0.3V to (VCHGIN + 0.3V)
VDISA to GND	-0.3V to (VBATA + 0.3V)
VDISB to GND	-0.3V to (VBATB + 0.3V)
VDD, VCHRG, VBATSEL, VRELN, VOUT0, VOUT1, VOUT2, VMINVA, VMINVB, VAIRDET, VACDET to GND	-0.3V to +6V

Continuous Power Dissipation (T _A = +70°C) 28-Pin Thin QFN 5mm x 5mm (derate 20.8mW/°C above +70°C)	1666.7mW
Operating Temperature Range MAX1538ETI	-40°C to +85°C
Junction Temperature	+150°C
Storage Temperature Range	-65°C to +150°C
Lead Temperature (soldering, 10s)	+300°C

Stresses beyond those listed under "Absolute Maximum Ratings" may cause permanent damage to the device. These are stress ratings only, and functional operation of the device at these or any other conditions beyond those indicated in the operational sections of the specifications is not implied. Exposure to absolute maximum rating conditions for extended periods may affect device reliability.

ELECTRICAL CHARACTERISTICS

(VBATA = VBATB = VCHGIN = 16.8V, CVDD = 1μF, VMINVA = VMINVB = 0.93V, VEXTLD = VADPIN = 28V, VCHRG = VBATSEL = VRELN = 0, CADPPWR = CREVLK = CADPBLK = CDISBAT = CDISA = CDISB = CCHGA = CCHGB = 4.7nF, T_A = 0°C to +85°C, unless otherwise noted. Typical values are at T_A = +25°C.)

PARAMETER	CONDITIONS	MIN	TYP	MAX	UNITS
ADPIN, EXTLD Supply Voltage Range		4.75		28.00	V
CHGIN, BATA, BATB and BATSUP Supply Voltage Range		4.75		19.00	V
ADPIN, BATA, BATB, BATSUP Quiescent Current (Current from the Highest Voltage Supply)	VADPIN = highest, VADPPWR = high		21	50	μA
	VADPIN = highest, VADPPWR = low		23	54	
	VBATA = highest, VDISA = high		21	42	
	VBATA = highest, VDISA = low		24	50	
	VBATB = highest, VDISB = high		21	42	
	VBATB = highest, VDISB = low		24	50	
	VBATSUP = highest		18	40	
ADPIN Quiescent Current (ADPIN Current When Not the Highest Voltage)	VADPIN = 4.75V to 18V, no external load at VDD				μA
	VADPPWR = high		0.01	0.5	
BATA Quiescent Current (BATA Current When Not the Highest Voltage)	VBATA = 4.75V to 19V, no external load at VDD	VDISA = high	3.9	6.0	μA
		VDISA = low	7.0	12	
BATB Quiescent Current (BATB Current When Not the Highest Voltage)	VBATB = 4.75V to 19V, no external load at VDD	VDISB = high	3.9	6.0	μA
		VDISB = low	7.0	12	
EXTLD Quiescent Current	Adapter selected (REVLK or ADPBLK pins low)		3.0	6.1	μA
	Adapter not selected (REVLK and ADPBLK pins high)		0.02	1.0	
CHGIN Quiescent Current	AC or airline state (CHGA, CHGB, and DISBAT pins high)		0.03	1.5	μA
	Charge state (CHGA or CHGB pin low, DISBAT pin high)		3.1	6.2	
	Discharge or relearn state (CHGA or CHGB pin low, DISBAT pin low)		6.1	12.1	

Power-Source Selector for Dual-Battery Systems

MAX1538

ELECTRICAL CHARACTERISTICS (continued)

($V_{BATA} = V_{BATB} = V_{CHGIN} = 16.8V$, $C_{VDD} = 1\mu F$, $V_{MINVA} = V_{MINVB} = 0.93V$, $V_{EXTLD} = V_{ADPIN} = 28V$, $V_{CHRG} = V_{BATSEL} = V_{RELRN} = 0$, $C_{ADPPWR} = C_{REVBLK} = C_{ADPBLK} = C_{DISBAT} = C_{DISA} = C_{DISB} = C_{CHGA} = C_{CHGB} = 4.7nF$, $T_A = 0^{\circ}C$ to $+85^{\circ}C$, unless otherwise noted. Typical values are at $T_A = +25^{\circ}C$.)

PARAMETER	CONDITIONS	MIN	TYP	MAX	UNITS	
LINEAR REGULATOR						
V_{DD} Output Voltage	$I_{VDD} = 0$ to $100\mu A$	3.270	3.3	3.330	V	
V_{DD} Power-Supply Rejection Ratio	V_{BATA} or $V_{BATB} = 5V$ to $19V$, $V_{ADPIN} = 5V$			1.0	mV/V	
	$V_{BATA} = V_{BATB} = 5V$, $V_{ADPIN} = 5V$ to $28V$			1.0		
	V_{BATA} , V_{BATB} , or $V_{ADPIN} = 5V$ to $19V$, sawtooth at $10V/\mu s$, other supplies = $12V$		1			
V_{DD} Undervoltage Lockout	Rising edge, relative to regulation point	-55		-10	mV	
COMPARATORS						
ACDET, AIRDET Input Voltage Range		0		5.5	V	
ACDET, AIRDET Input Bias Current	$V_{AIRDET} = V_{ACDET} = 3V$		0.1	1	μA	
ACDET, AIRDET Trip Threshold	Input falling	1.97	2.0	2.03	V	
ACDET, AIRDET Hysteresis			20		mV	
MINV_ Operating Voltage Range		0.93		2.60	V	
MINV_ Input Bias Current	$V_{MINV_} = 0.93V$ to $2.6V$	-50		+50	nA	
BAT_ Minimum Voltage Trip Threshold	$V_{BAT_}$ falling	$V_{MINV_} = 0.93V$	4.605	4.65	4.695	V
		$V_{MINV_} = 1.5V$	7.455	7.5	7.545	
		$V_{MINV_} = 2.6V$	12.93	13	13.07	
BAT_ Minimum Voltage Hysteresis			125		mV	
BAT_ Pack Removal Detection Threshold	$V_{BAT_}$ falling	1.90	2.0	2.10	V	
BAT_ Pack Removal Hysteresis			85		mV	
GATE DRIVERS (Note 1)						
ADPPWR, REVBLK, ADPBLK, DISBAT, DISA, DISB, CHGA, CHGB Source Current (PMOS Turn-Off)	$V_{SOURCE} = 15V$, $V_{PIN} = 7.5V$	18	60		mA	
	$V_{SOURCE} = 15V$, $V_{PIN} = 13V$	3	15			
ADPPWR, REVBLK, ADPBLK, DISBAT, DISA, DISB, CHGA, CHGB Sink Current (PMOS Turn-On)	$V_{SOURCE} = 15V$, $V_{PIN} = 15V$	20	70		mA	
	$V_{SOURCE} = 15V$, $V_{PIN} = 9.5V$	10	55			
ADPPWR, REVBLK, ADPBLK, DISBAT, DISA, DISB, CHGA, CHGB Turn-On Clamp Voltage (V_{PIN} to V_{SOURCE})	$V_{SOURCE} = 8V$ to $19V$ (ADPPWR, REVBLK, and AOPBLK, $V_{SOURCE} = 8V$ to $28V$)	-11.0	-9.0	-7.0	V	
	$V_{SOURCE} = 4.75V$ to $8V$	-8.00		-3.65		

Power-Source Selector for Dual-Battery Systems

ELECTRICAL CHARACTERISTICS (continued)

($V_{BATA} = V_{BATB} = V_{CHGIN} = 16.8V$, $C_{VDD} = 1\mu F$, $V_{MINVA} = V_{MINVB} = 0.93V$, $V_{EXTLD} = V_{ADPIN} = 28V$, $V_{CHRG} = V_{BATSEL} = V_{RELRN} = 0$, $C_{ADPPWR} = C_{REVBLK} = C_{ADPBLK} = C_{DISBAT} = C_{DISA} = C_{DISB} = C_{CHGA} = C_{CHGB} = 4.7nF$, $T_A = 0^{\circ}C$ to $+85^{\circ}C$, unless otherwise noted. Typical values are at $T_A = +25^{\circ}C$.)

PARAMETER	SYMBOL	CONDITIONS	MIN	TYP	MAX	UNITS
ADPPWR, REVBLK, ADPBLK, DISBAT, DISA, DISB, CHGA, CHGB Turn-On Time		$V_{SOURCE} = 15V$, $V_{PIN} = 13V$ to $V_{PIN} = 9V$		0.3	0.88	μs
ADPPWR, REVBLK, ADPBLK, DISBAT, DISA, DISB, CHGA, CHGB Turn-Off Time		$V_{SOURCE} = 15V$, $V_{PIN} = 9V$ to $V_{PIN} = 13V$		0.3	0.88	μs
STATE SELECTION INPUTS						
CHRG, BATSEL, RELRN Input Low Voltage					0.8	V
CHRG, BATSEL, RELRN Input High Voltage			2.1			V
CHRG, BATSEL, RELRN Input Leakage Current		$V_{CHRG} = V_{BATSEL} = V_{RELRN} = 5.5V$		0.1	1	μA
STATE OUTPUTS						
OUT0, OUT1, OUT2 Sink Current		$V_{OUT_} = 0.4V$	1			mA
		$V_{OUT_} = 5.5V$	25			
OUT0, OUT1, OUT2 Leakage Current	$V_{OUT_} = 5.5V$			0.1	1	μA
TRANSITION TIMES						
MINV_ Comparator Delay	t_{MINV}	$V_{BAT_} = 5.5V$ to $V_{BAT_} = 4.45V$		5.5	11	μs
AIRDET and ACDET Comparator Delay	t_{ADP}	Falling edge with -20mV overdrive		2.7	6.0	μs
BAT_ Removal Comparator Delay		Falling edge with -20mV overdrive		10		μs
Battery-Insertion Blanking Time	t_{BBLANK}		13	21	31	ms
State-Machine Delay				50		ns
MOSFET Turn-On Delay	t_{TRANS}		5	7.5	10	μs

Power-Source Selector for Dual-Battery Systems

MAX1538

ELECTRICAL CHARACTERISTICS

($V_{BATA} = V_{BATB} = V_{CHGIN} = 16.8V$, $C_{VDD} = 1\mu F$, $V_{MINVA} = V_{MINVB} = 0.93V$, $V_{EXTLD} = V_{ADPIN} = 28V$, $V_{CHRG} = V_{BATSEL} = V_{RELRN} = 0$, $C_{ADPPWR} = C_{REVBLK} = C_{ADPBLK} = C_{DISBAT} = C_{DISA} = C_{DISB} = C_{CHGA} = C_{CHGB} = 4.7nF$, $T_A = -40^{\circ}C$ to $+85^{\circ}C$, unless otherwise noted.) (Note 2)

PARAMETER	CONDITIONS		MIN	MAX	UNITS
ADPIN, EXTLD Supply Voltage Range			4.75	28.00	V
CHGIN, BATA, BATB, and BATSUP Supply Voltage Range			4.75	19.00	V
ADPIN, BATA, BATB, BATSUP Quiescent Current (Current from the Highest Voltage Supply)	$V_{BATA} = 4.75V$ to $19V$, $V_{BATB} = 4.75V$ to $19V$, $V_{BATSUP} = 4.75V$ to $19V$, $V_{ADPIN} = 4.75V$ to $28V$, no external load at V_{DD}	$V_{ADPIN} =$ highest, $V_{ADPPWR} =$ high		50	μA
		$V_{ADPIN} =$ highest, $V_{ADPPWR} =$ low		54	
		$V_{BATA} =$ highest, $V_{DISA} =$ high		42	
		$V_{BATA} =$ highest, $V_{DISA} =$ low		50	
		$V_{BATB} =$ highest, $V_{DISB} =$ high		42	
		$V_{BATB} =$ highest, $V_{DISB} =$ low		50	
		$V_{BATSUP} =$ highest		40	
ADPIN Quiescent Current (ADPIN Current When Not the Highest Voltage)	$V_{ADPIN} = 4.75V$ to $18V$, no external load at V_{DD}	$V_{ADPPWR} =$ high		1	μA
		$V_{ADPPWR} =$ low		9	
BATA Quiescent Current (BATA Current When Not the Highest Voltage)	$V_{BATA} = 4.75V$ to $19V$, no external load at V_{DD}	$V_{DISA} =$ high		7.5	μA
		$V_{DISA} =$ low		16	
BATB Quiescent Current (BATB Current When Not the Highest Voltage)	$V_{BATB} = 4.75V$ to $19V$, no external load at V_{DD}	$V_{DISB} =$ high		7.5	μA
		$V_{DISB} =$ low		16	
EXTLD Quiescent Current	Adapter selected (REVBLK or ADPBLK pins low)			9.5	μA
	Adapter not selected (REVBLK and ADPBLK pins high)			1.0	
CHGIN Quiescent Current	AC or airline state (CHGA, CHGB, and DISBAT pins high)			1.5	μA
	Charge state (CHGA or CHGB pin low, DISBAT pin high)			10	
	Discharge or relearn state (CHGA or CHGB pin low, DISBAT pin low)			18.5	
LINEAR REGULATOR					
V_{DD} Output Voltage	$I_{VDD} = 0$ to $100\mu A$		3.270	3.330	V
V_{DD} Undervoltage Lockout	Rising edge, relative to regulation point		-60	-10	mV
COMPARATORS					
ACDET, AIRDET Input Voltage Range			0	5.5	V
ACDET, AIRDET Trip Threshold	Input falling		1.94	2.06	V
MINV_ Operating Voltage Range			0.93	2.60	V
BAT_ Minimum Voltage Trip Threshold	$V_{BAT_falling}$	$V_{MINV_} = 0.93V$	4.59	4.72	V
		$V_{MINV_} = 1.5V$	7.4	7.6	
		$V_{MINV_} = 2.6V$	12.86	13.14	

Power-Source Selector for Dual-Battery Systems

ELECTRICAL CHARACTERISTICS (continued)

($V_{BATA} = V_{BATB} = V_{CHGIN} = 16.8V$, $C_{VDD} = 1\mu F$, $V_{MINVA} = V_{MINVB} = 0.93V$, $V_{EXTLD} = V_{ADPIN} = 28V$, $V_{CHRG} = V_{BATSEL} = V_{RELRN} = 0$, $C_{ADPPWR} = C_{REVBLK} = C_{ADPBLK} = C_{DISBAT} = C_{DISA} = C_{DISB} = C_{CHGA} = C_{CHGB} = 4.7nF$, $T_A = -40^{\circ}C$ to $+85^{\circ}C$, unless otherwise noted.) (Note 2)

PARAMETER	SYMBOL	CONDITIONS	MIN	MAX	UNITS
BAT_ Pack Removal Detection Threshold		$V_{BAT_}$ falling	1.88	2.12	V
GATE DRIVERS (Note 1)					
ADPPWR, REVBLK, ADPBLK, DISBAT, DISA, DISB, CHGA, CHGB Source Current (PMOS Turn-Off)		$V_{SOURCE} = 15V$, $V_{PIN} = 7.5V$	18		mA
		$V_{SOURCE} = 15V$, $V_{PIN} = 13V$	3		
ADPPWR, REVBLK, ADPBLK, DISBAT, DISA, DISB, CHGA, CHGB Sink Current (PMOS Turn-On)		$V_{SOURCE} = 15V$, $V_{PIN} = 15V$	20		mA
		$V_{SOURCE} = 15V$, $V_{PIN} = 9.5V$	10		
ADPPWR, REVBLK, ADPBLK, DISBAT, DISA, DISB, CHGA, CHGB Turn-On Clamp Voltage (V_{PIN} to V_{SOURCE})		$V_{SOURCE} = 8V$ to $19V$ (ADPPWR, REVBLK, and ADPBLK, $V_{SOURCE} = 8V$ to $28V$)	-11.7	-6.5	V
		$V_{SOURCE} = 4.75V$ to $8V$	-8.00	-3.50	
ADPPWR, REVBLK, ADPBLK, DISBAT, DISA, DISB, CHGA, CHGB Turn-On Time		$V_{SOURCE} = 15V$, $V_{PIN} = 13V$ to $V_{PIN} = 9V$		0.88	μs
ADPPWR, REVBLK, ADPBLK, DISBAT, DISA, DISB, CHGA, CHGB Turn-Off Time		$V_{SOURCE} = 15V$, $V_{PIN} = 9V$ to $V_{PIN} = 13V$		0.88	μs
STATE SELECTION INPUTS					
CHRG, BATSEL, RELRN Input Low Voltage				0.8	V
CHRG, BATSEL, RELRN Input High Voltage			2.1		V
STATE OUTPUTS					
OUT0, OUT1, OUT2 Sink Current	$V_{OUT_} = 0.4V$		1		mA
	$V_{OUT_} = 5.5V$		25		
TRANSITION TIMES					
MINV_ Comparator Delay	t_{MINV}	$V_{BAT_} = 5.5V$ to $V_{BAT_} = 4.45V$		11	μs
AIRDET and ACDET Comparator Delay	t_{ADP}	Falling edge with $-20mV$ overdrive		6	μs
Battery-Insertion Blanking Time	t_{BBLANK}		12	31	ms
MOSFET Turn-On Delay	t_{TRANS}		5	10	μs

Note 1: V_{PIN} refers to the voltage of the driver output. V_{SOURCE} refers to the power source for the driver. ADPPWR, REVBLK, ADPBLK, DISBAT, DISA, DISB, CHGA, and CHGB gate drivers correspond to sources at ADPIN, EXTLD, EXTLD, CHGIN, BATA, BATB, CHGIN, and CHGIN, respectively.

Note 2: Guaranteed by design. Not production tested.

Power-Source Selector for Dual-Battery Systems

Typical Operating Characteristics

(Circuit of Figure 1. $T_A = +25^\circ\text{C}$, unless otherwise noted.)

MAX1538

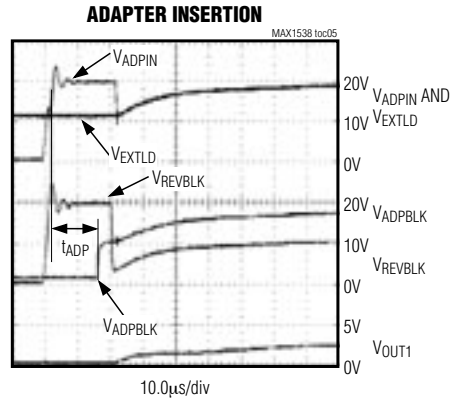
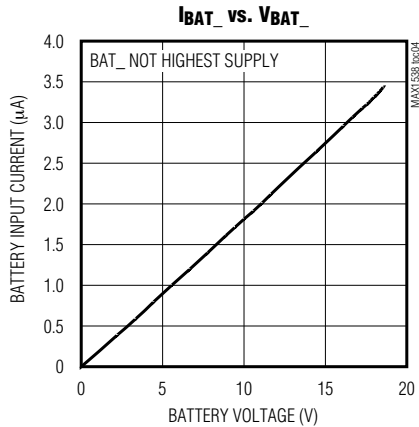
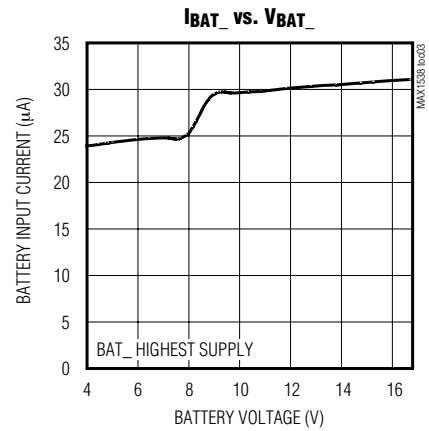
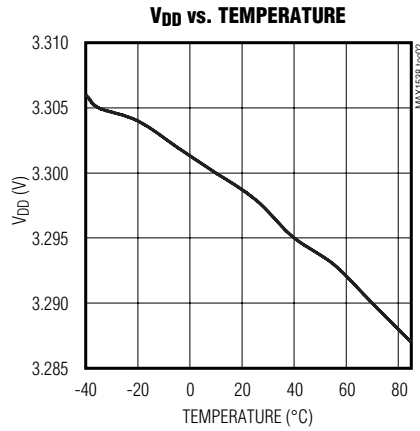
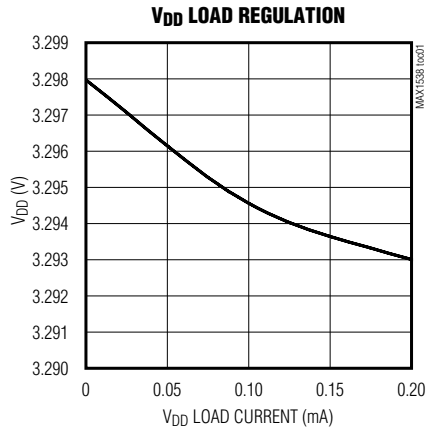

Power-Source Selector for Dual-Battery Systems

Typical Operating Characteristics (continued)

(Circuit of Figure 1. $T_A = +25^\circ\text{C}$, unless otherwise noted.)

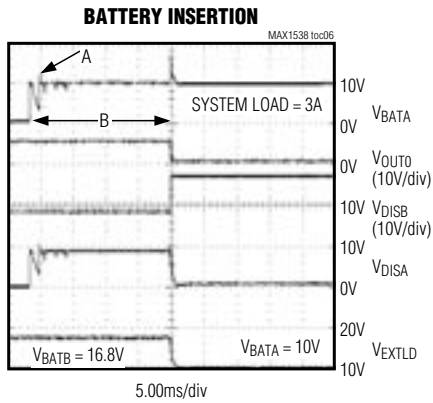

A: CONTACT BOUNCE
B: BATTERY INSERTION BLANKING TIME = 22ms

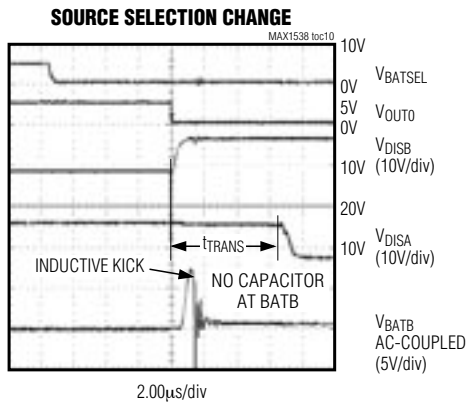
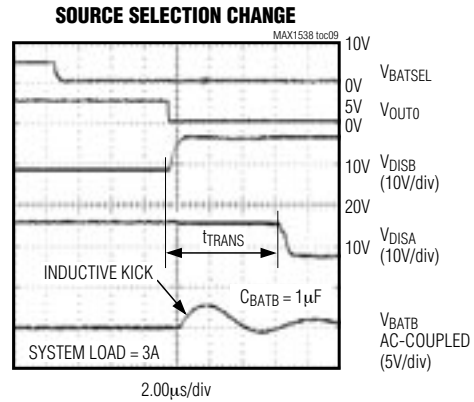
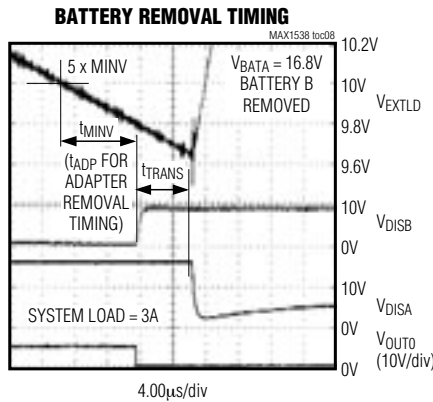
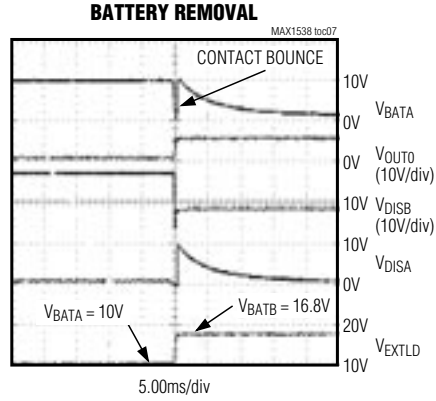

Power-Source Selector for Dual-Battery Systems

MAX1538

Typical Operating Characteristics (continued)

(Circuit of Figure 1. $T_A = +25^\circ\text{C}$, unless otherwise noted.)

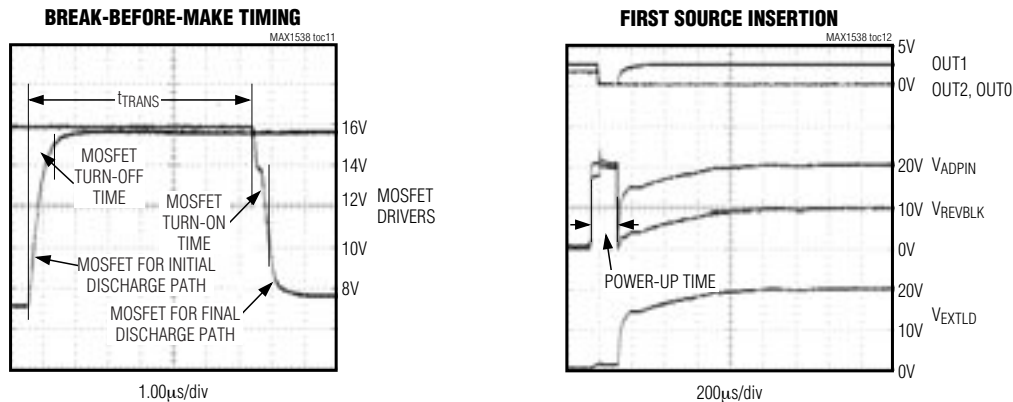

Pin Description

PIN	NAME	FUNCTION
1	MINVA	Minimum Battery A Voltage Set Point. Battery A discharge is prevented if V_{BATA} has fallen below $5 \times V_{MINVA}$.
2	MINVB	Minimum Battery B Voltage Set Point. Battery B discharge is prevented if V_{BATB} has fallen below $5 \times V_{MINVB}$.
3	BATSEL	Battery-Selection Input. Drive to logic low to charge battery A or give discharge preference to battery A. Drive to logic high to charge battery B or give discharge preference to battery B.
4	RELRN	Battery-Relearn Logic-Level Input. Drive RELRN high to enable battery-relearn mode.
5	CHRG	Charge-Enable Logic-Level Input. Drive CHRG high to enable the charging path from the charger to the battery selected by BATSEL.
6	OUT0	Selector-State Output. This open-drain output indicates the state of the MAX1538. See Table 1 for information on decoding.
7	OUT1	
8	OUT2	
9	ACDET	AC-Adapter Detection Input. When V_{ACDET} is greater than the ACDET trip threshold (2V typ), adapter presence is detected.
10	AIRDET	Airline-Adapter Detection Input. When $V_{AIRDET} > 2\text{V}$ and $V_{ACDET} < 2\text{V}$, the airline-adapter presence is detected. Charging is disabled when an airline adapter is detected.
11	ADPIN	Adapter Input. When $V_{ADPIN} > V_{BATSUP}$, the MAX1538 is powered by ADPIN. ADPIN is the supply rail for the ADPPWR MOSFET driver.
12	ADPPWR	Adapter-Power P-Channel MOSFET Driver. Connect ADPPWR to the gate of P1 (Figure 1). P1 disconnects the adapter from the system during relearn mode. Exclude P1 and leave ADPPWR disconnected if relearn is not used. ADPPWR is driven relative to ADPIN. ADPPWR and REVBLK are driven with the same control signal.
13	REVBLK	Gate Drive for the Reverse-Blocking P-Channel MOSFET. Connect REVBLK to the gate of P2 (Figure 1). P2 enables and disables the AC adapter's power path. REVBLK is driven relative to EXTLD. REVBLK and ADPPWR are driven with the same control signal.

Power-Source Selector for Dual-Battery Systems

Pin Description (continued)

PIN	NAME	FUNCTION
14	ADPBLK	Gate Drive for the Adapter-Blocking P-Channel MOSFET. Connect ADPBLK to the gate of P3 (Figure 1). P3 enables and disables the battery discharge path. ADPBLK is driven relative to EXTLD. ADPBLK and DISBAT are driven with the same control signal.
15, 21	N.C.	Not Internally Connected
16	EXTLD	External Load. EXTLD is the supply rail for REVBLK and ADPBLK.
17	CHGIN	Charger Node Input. CHGIN is the supply rail for DISBAT, CHGA, and CHGB.
18	DISBAT	Gate Drive for the Battery-Discharge P-Channel MOSFET. Connect DISBAT to the gate of P4 (Figure 2). P4 disconnects the battery from the system load when charging from a step-up converter. Exclude P4 and leave DISBAT disconnected if using a step-down charger. DISBAT is driven relative to CHGIN. DISBAT and ADPBLK are driven by the same control signal.
19	CHGA	Gate Drive for the Charge Battery A P-Channel MOSFET. Connect CHGA to the gate of P6 (Figure 1). P6 enables and disables the charge path into battery A. CHGA is driven relative to CHGIN. CHGA and DISA are driven by the same control signal.
20	CHGB	Gate Drive for the Charge Battery B P-Channel MOSFET. Connect CHGB to the gate of P7 (Figure 1). P7 enables and disables the charge path into battery B. CHGB is driven relative to CHGIN. CHGB and DISB are driven by the same control signal.
22	BATB	Battery B Voltage Input. Battery undervoltage and absence is determined by measuring BATB. BATB is the supply rail for DISB.
23	DISB	Gate Drive for the Discharge from Battery B P-Channel MOSFET. Connect DISB to the gate of P8 (Figure 1). P8 enables and disables the discharge path from battery B. DISB is driven relative to BATB. DISB and CHGB are driven by the same control signal.
24	DISA	Gate Drive for the Discharge from Battery A P-Channel MOSFET. Connect DISA to the gate of P5 (Figure 1). P5 enables and disables the discharge path from battery A. DISA is driven relative to BATA. DISA and CHGA are driven by the same control signal.
25	BATA	Battery A Voltage Input. Battery undervoltage and absence is determined by measuring BATA. BATA is the supply rail for DISA.
26	BATSUP	BATSUP powers the MAX1538. Diode OR BATA and BATB to BATSUP externally. ADPIN is diode connected to BATSUP internally. Bypass with a 0.1 μ F capacitor from BATSUP to GND.
27	GND	Ground
28	VDD	Linear-Regulator Output. Bypass with a 1 μ F capacitor from VDD to GND.

Power-Source Selector for Dual-Battery Systems

MAX1538

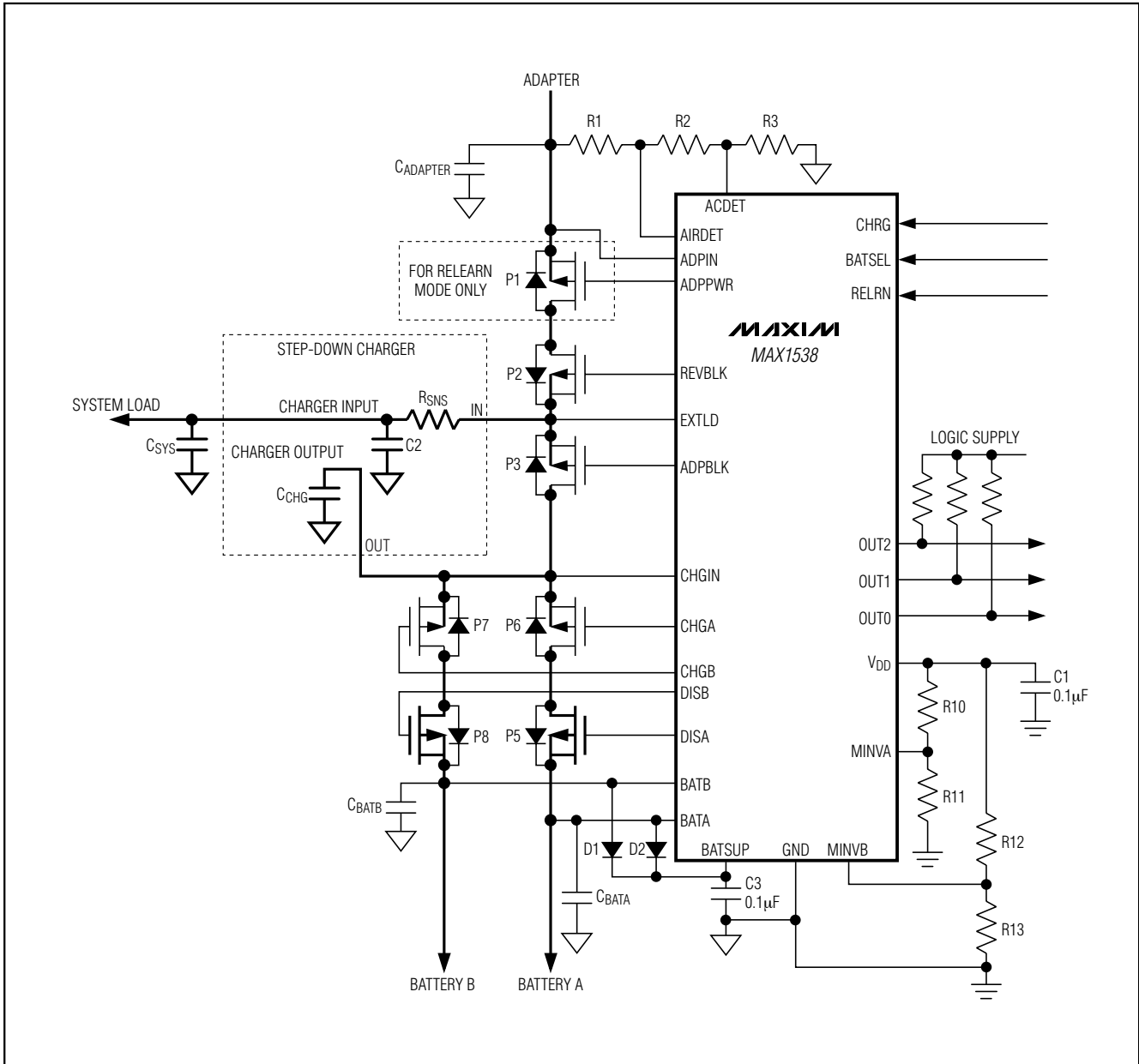

Figure 1. Step-Down Typical Application Circuit

Power-Source Selector for Dual-Battery Systems

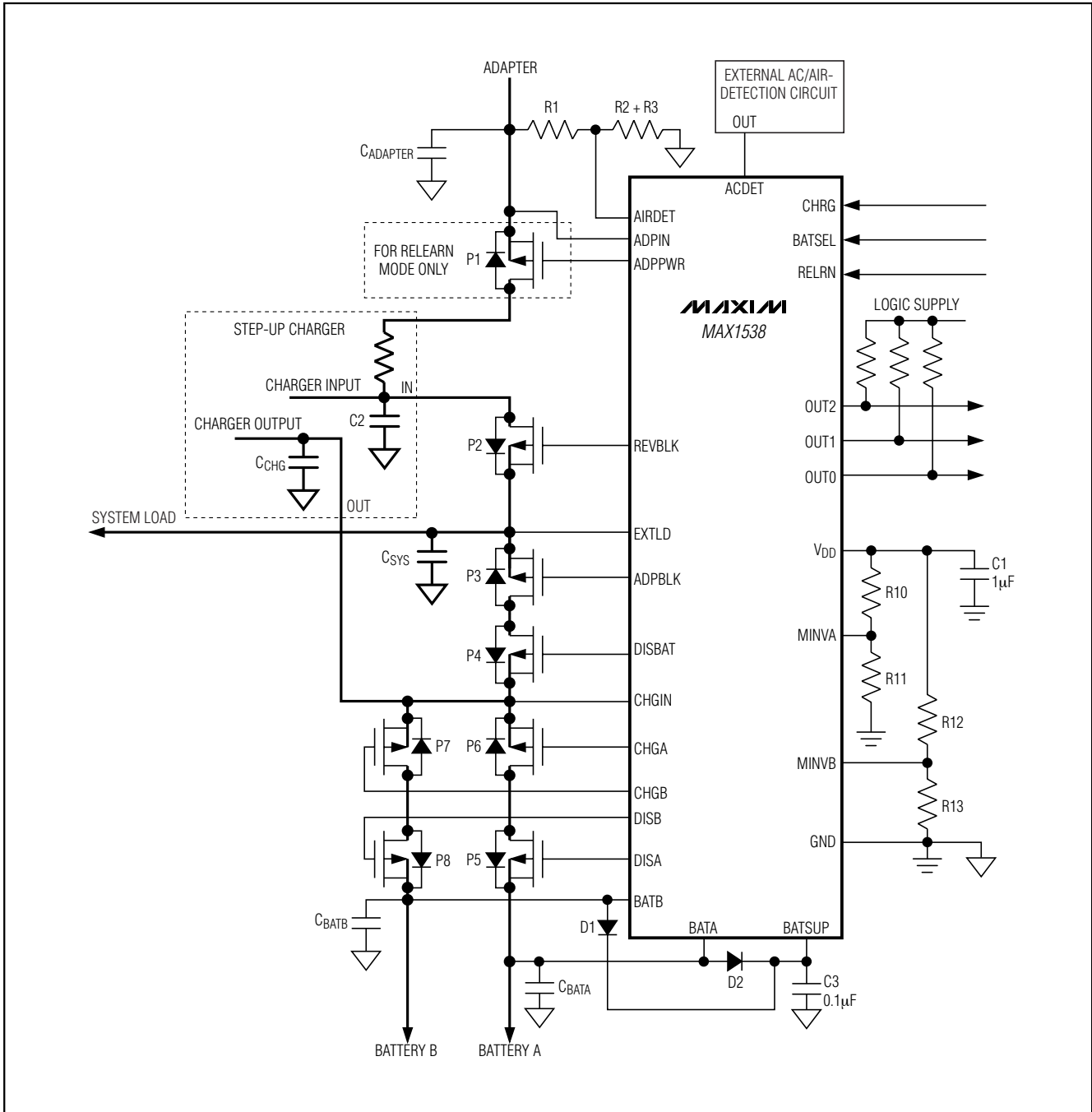

Figure 2. Typical Application Circuit for Step-Up/Step-Down Charger

Power-Source Selector for Dual-Battery Systems

MAX1538

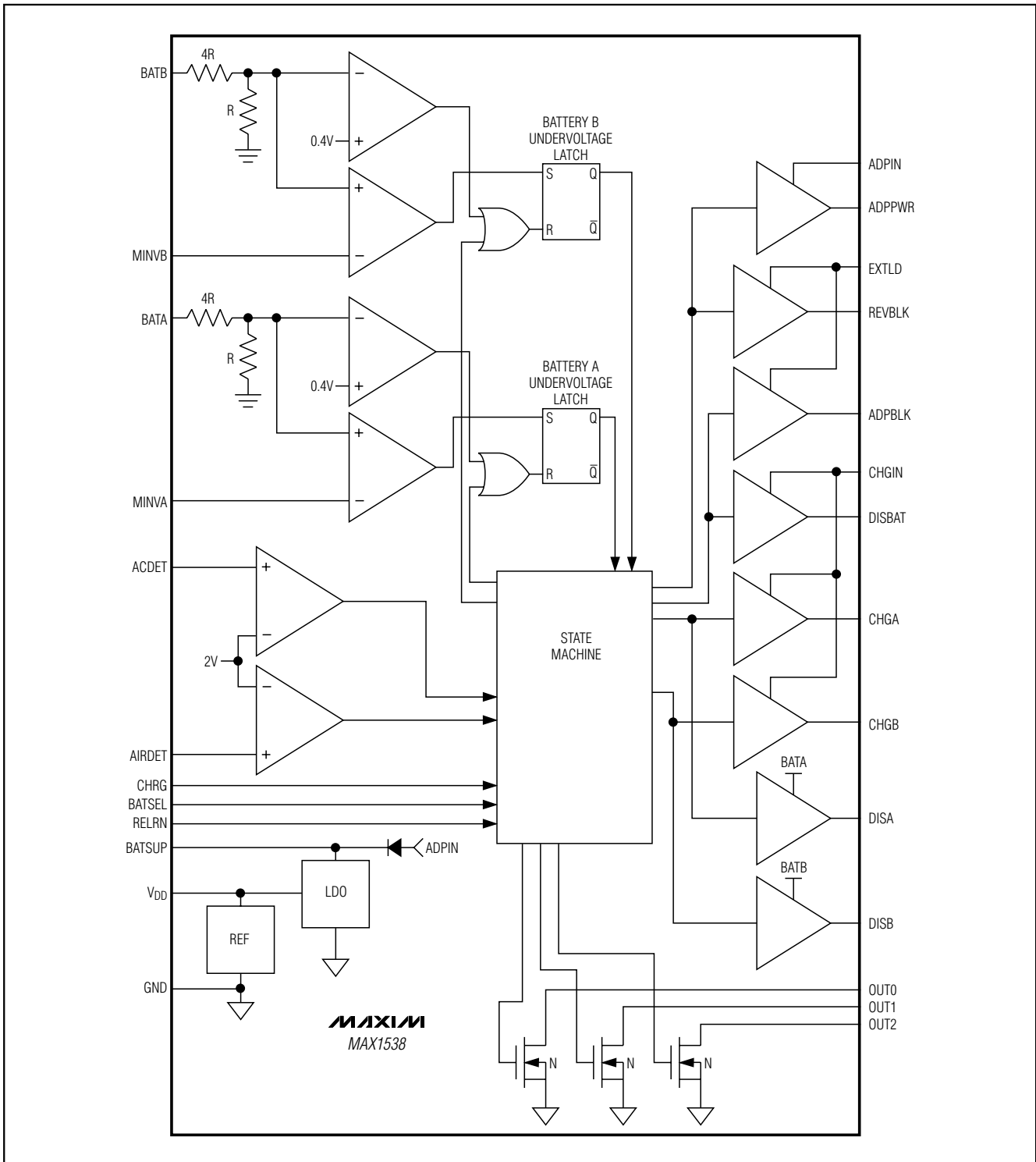

Figure 3. Functional Diagram

Power-Source Selector for Dual-Battery Systems

Detailed Description

The MAX1538 performs power path selection between an adapter input and two batteries, relieving the host system from the burden of real-time response to power-source changes. The integrated selector implements a fixed break-before-make timer to ensure that power sources are not connected together and yet the load is not left unserved. The MAX1538 monitors battery and adapter state and presence to determine which source to select and whether to charge the battery. Logic inputs CHRG, BATSEL, and RELRN allow the host to enable/disable charging, select which battery to use, and impose battery discharge even with adapter presence. The MAX1538 automatically detects airline adapters and prevents charging when an airline adapter is detected. Open-drain logic outputs OUT2,

OUT1, and OUT0 indicate the state of the selector so the host can properly respond.

The MAX1538 can be configured for use with a step-down battery charger, as shown in Figure 1, or with a step-up/step-down battery charger, as shown in Figure 2. The minimum MAX1538 system requires only six MOSFETs. The MAX1538 provides relearn-mode support with the addition of P1. Relearn mode allows the system to relearn the battery's capacity without user intervention.

Table 1 summarizes the possible states and configurations of the MAX1538.

Table 1. MAX1538 State Table

SOURCE STATE			LOGIC INPUTS			MOSFET STATE (See Figure 4)				OUT2	OUT1	OUT0	STATE
Adapter	Battery		CHRG	RELRN	BATSEL	System (ADPPWR and REVBLK)	Battery (ADPBLK and DISBAT)	BATT A (CHGA and DISA)	BATT B (CHGB and DISB)				
	A	B											
AC	X	X	1	0	0	On	Off	On	Off	1	1	0	Charge A
AC	X	X	1	0	1	On	Off	Off	On	1	1	1	Charge B
AC	N	X	X	1	0	Off	On	On	Off	1	0	0	Relearn A
AC	X	N	X	1	1	Off	On	Off	On	1	0	1	Relearn B
AC	Otherwise					On	Off	Off	Off	0	1	0	AC adapter
AIR	X	X	X	X	X	On	Off	Off	Off	0	1	1	Airline
Absent	N	X	X	X	0	Off	On	On	Off	0	0	0	Discharge A
Absent	N	U	X	X	X								
Absent	X	N	X	X	1	Off	On	Off	On	0	0	1	Discharge B
Absent	U	N	X	X	X								
Absent	U	U	X	X	X	Off	Off	Off	Off	0	0	0	Idle
Legend													
AC	AC adapter is present. V_{ACDET} and V_{AIRDET} are both above 2V.												
AIR	Airline adapter is present. V_{ACDET} is below 2V and V_{AIRDET} is above 2V.												
Absent	External adapter is absent. V_{ACDET} and V_{AIRDET} are both below 2V.												
	N	N indicates the battery is normal. The battery is normal when it has not tripped the undervoltage latch ($5 \times V_{MINV_}$). See the <i>Battery Presence and Undervoltage Detection</i> section.											
	U	U indicates the battery has tripped the undervoltage comparator. An undervoltage battery is detected when $V_{BAT_}$ goes below $5 \times V_{MINV_}$. See the <i>Battery Presence and Undervoltage Detection</i> section.											
	Otherwise					Otherwise covers all cases not explicitly shown elsewhere in the table.							
	X	X	X	X	X	X indicates don't care. The output does not depend on any inputs labeled X.							

Power-Source Selector for Dual-Battery Systems

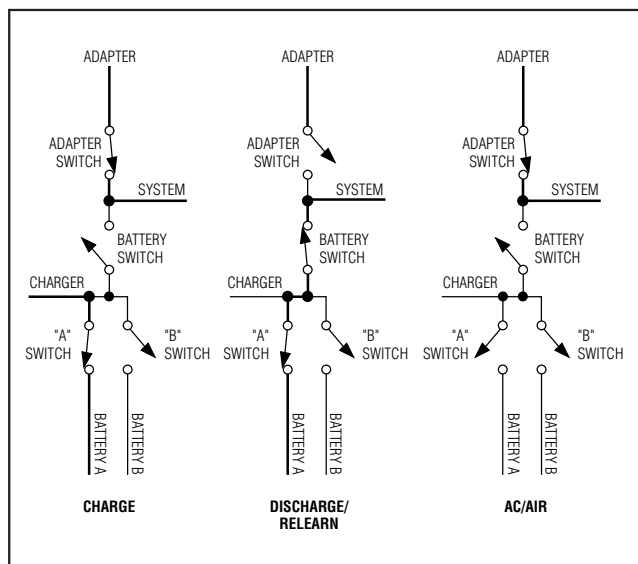

Figure 4. MAX1538 Selection States

Battery Presence and Undervoltage Detection

The MAX1538 determines battery absence and undervoltage and does not allow discharge from an undervoltage battery. A battery is considered undervoltage when $V_{BAT_} < 5 \times V_{MINV_}$, and remains classified as undervoltage until $V_{BAT_}$ falls below 2V and again rises above $5 \times V_{MINV_}$. The undervoltage latch is also cleared when the charge path is enabled. Set the battery undervoltage threshold using resistive voltage-dividers R10, R11, R12, and R13, as shown in Figure 1. The corresponding undervoltage threshold is:

$$V_{BATA_Undervoltage} = 5 \times V_{DD} \times \frac{R11}{R10 + R11}$$

$$V_{BATB_Undervoltage} = 5 \times V_{DD} \times \frac{R13}{R12 + R13}$$

To minimize error, use 1% or better accuracy divider resistors, and ensure that the impedance of the divider results in a current about 100 times the $MINV_$ input bias current at the $MINV_$ threshold voltage. To optimize error due to 50nA input bias current at $MINV_$ and minimize current consumption, typically choose resistors (R10 + R11) or (R12 + R13) smaller than 600k Ω .

Since batteries often exhibit large changes in their terminal voltage when a load current is removed, further discharge after the undervoltage latch has been set is

not allowed until the battery is removed or the charge path to the battery is selected. Battery removal is detected when $V_{BAT_}$ falls below 2V. For correct detection of battery removal, ensure that the leakage current into $BAT_$ is lower than the leakage current out of $BAT_$ so that $BAT_$ falls below 2V when the battery is removed. The contributors to leakage current into $BAT_$ are D1, D2, P6, and P7.

Battery Relearn Mode

The MAX1538 implements a battery relearn mode, which allows for host-device manufacturers to implement a mode for coulomb-counting fuel gauges (such as the MAX1781) to measure battery capacity without user intervention. In battery relearn mode, the AC adapter is switched off and battery discharge is selected. In this implementation, the host system could prompt users when their battery capacity becomes inaccurate, use the host system as a load to discharge the battery, and then recharge the battery fully. Coulomb-counting fuel-gauge accuracy is increased after a relearning cycle.

Battery relearn mode requires the addition of MOSFET P1, which blocks current from the adapter to the system. To enable relearn mode, drive RELRN high and drive BATSEL low to relearn battery A or high to relearn battery B. Relearn mode overrides the functionality of the CHG pin. Battery relearn mode does not occur when the selected battery's undervoltage latch has been set, or when the selector is in airline mode (see the *Airline Mode and AC Adapter* section.) The RELRN pin only applies when an AC adapter is present. If the AC adapter is absent and RELRN is ignored, $OUT[2:1] = 10$ when the MAX1538 is in battery relearn mode. If $CHG = 0$, only OUT2 is needed to indicate that the MAX1538 was properly placed in relearn mode.

If the selected battery trips the undervoltage latch when in relearn mode, the AC adapter is switched in without causing a crash to the system. OUT2 can indicate that the relearn cycle is terminated due to battery undervoltage. Typically, after the host system performs a battery relearn cycle, it either charges the discharged battery or begins a relearn cycle on the other battery. To switch to charge mode, drive RELRN low and CHG high. Since RELRN overrides CHG, in many applications it is best to permanently keep CHG high and reduce the IO needed to control the selector.

When the AC adapter is available, it is used as the power source for EXTLD unless the RELRN pin is high. In this state, the charger can be enabled and a battery charged.

Power-Source Selector for Dual-Battery Systems

Airline Mode and AC Adapter

The MAX1538 provides compatibility with airline adapters. For airplane safety, the use of an airline adapter requires that the battery charger or charge path is disabled. The MAX1538 disables the charge path when an airline adapter is detected. In airline mode, ADPPWR and REVBLK drive P1 and P2 on, and all other MOSFETs are off, regardless of the state of RELRN, CHG, BATSEL, or the batteries. If the AC threshold is above the airline threshold, select a resistive voltage-divider (as shown in Figure 1) according to the following equations:

$$V_{AC_Threshold} = V_{ACDET_Threshold} \times \frac{R1 + R2 + R3}{R3}$$

$$V_{Air_Threshold} = V_{AIRDET_Threshold} \times \frac{R1 + R2 + R3}{R2 + R3}$$

where $V_{ACDET_Threshold}$ and $V_{AIRDET_Threshold}$ are typically 2.0V (see the *Electrical Characteristics*). An AC adapter is detected when the adapter voltage is above $V_{AC_Threshold}$, and an airline adapter is detected when

the adapter voltage is between $V_{AC_Threshold}$ and $V_{AIR_Threshold}$.

To minimize error, use 1% accuracy or better divider resistors, and ensure that the impedance of the divider results in a current about 100 times the ACDET and AIRDET input bias current. To optimize error due to $1\mu A$ input bias current at ACDET/AIRDET and minimize current consumption, typically choose $R3$ less than $20k\Omega$. See the *Adapter Removal Debouncing* section for more information regarding $R1$, $R2$, and $R3$. Short $R2$ to disable airline-adapter mode.

Optionally, an external circuit can be implemented to determine the presence of an AC/airline adapter. The circuit in Figure 5 provides fast detection of an airline adapter, yet allows external circuitry to discriminate between airline and AC adapters. If $V_{AC_Threshold} < V_{AIR_Threshold}$, this circuit must be used for airline-adapter detection. Other permutations that directly drive AIRDET instead do not work properly on the MAX1538 because adapter removal is not detected fast enough, causing the system load to crash.

$OUT[2:0] = 011$ if the MAX1538 is in airline-adapter mode. If $RELRN = 0$ and $CHG = 0$, only $OUT[1:0]$ are necessary to indicate airline-adapter mode.

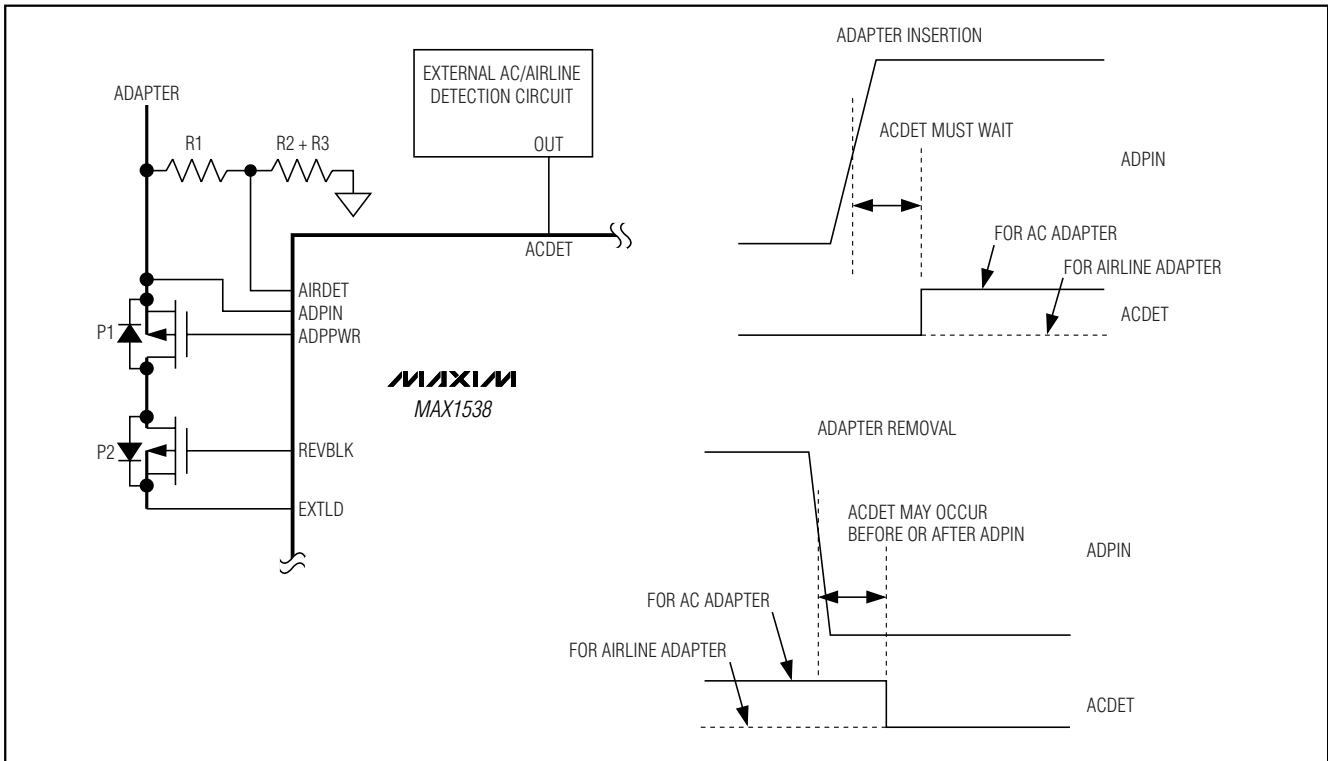

Figure 5. Using an External Adapter Detection Circuit

Power-Source Selector for Dual-Battery Systems

CHG Control

Toggle CHG to enable the charge path to the battery. Charge control is overridden by RELRN (see the *Battery Relearn Mode* section) or airline mode (see the *Airline Mode and AC Adapter* section). When CHG is enabled, the MAX1538 connects the selected battery (BATSEL = 0 for battery A and BATSEL = 1 for battery B) to the charger. $OUT[2:1] = 11$ if the MAX1538 is in charge mode. When the charge path is enabled, the corresponding battery undervoltage latch is cleared. This allows charging of protected battery packs. In typical applications, connect CHRG to VDD to reduce the system I/O.

Single Transition Break-Before-Make Selection

The MAX1538 guarantees that no supplies are connected to each other during any transition by implementing a fixed delay time (t_{TRANS} , the break-before-make transition timer). This is necessary as the batteries have very low impedances, and momentarily shorting batteries together can cause hundreds of amps to flow. For example, when adapter removal is detected, ADPPWR and REVBLK begin to turn off less than $10\mu s$ before ADPBLK and DISBAT begin to turn on, connecting the appropriate battery. For example, upon switching from one battery to another, DISA and CHGA begin turning off less than $10\mu s$ before DISB and CHGB begin to turn on. To guarantee a break-before-make time, ensure that the turn-off time of the MOSFETs is smaller than t_{TRANS} (see the *MOSFET Selection* section).

The MAX1538 also guarantees that any change does not cause unnecessary power-source transitions. When switching from battery to battery; battery to adapter; or adapter to battery because of adapter or battery insertion or removal, or due to a change at BATSEL, a single set of MOSFETs are turned off followed by another set of MOSFETs turned on. No additional transitions are necessary. The only exception occurs when RELRN is high and the adapter is inserted because it is first detected as an airline adapter and later detected as an AC adapter. This results in a transition from discharge mode to AC mode, followed by a transition from AC mode to relearn mode. Although this extra transition is generally harmless, it can be avoided by disabling relearn mode when the adapter is absent.

Blanking

The MAX1538 implements sophisticated blanking at the adapter and the batteries to correctly determine battery/adapter insertion and removal. Logic inputs CHRG, RELRN, and BATSEL should be debounced to ensure that fast repetitive transitions do not occur, in which

case the system holdup capacitor is not large enough to sustain the system load.

Battery insertion is automatically debounced using the battery-insertion blanking time (t_{BBLANK}). A battery is not discharged unless the battery has been above the $5 \times V_{MINV}$ threshold for 21ms (typ). After t_{BBLANK} is expired, $V_{BAT_}$ must exceed $5 \times V_{MINV_}$ or the battery is detected as undervoltage.

Applications Information

MOSFET Selection

Select P-channel MOSFETs P1–P8 according to their power dissipation, $R_{DS(on)}$, and gate charge. Each MOSFET must be rated for the full system load current. Additionally, the battery discharge MOSFETs (P3, P5, P6, P7, and P8) should be selected with low on-resistance for high discharge efficiency. Since for any given switch configuration at least half of the MOSFETs are off, dual MOSFETs can be used without reducing the effective MOSFET power dissipation. When using dual

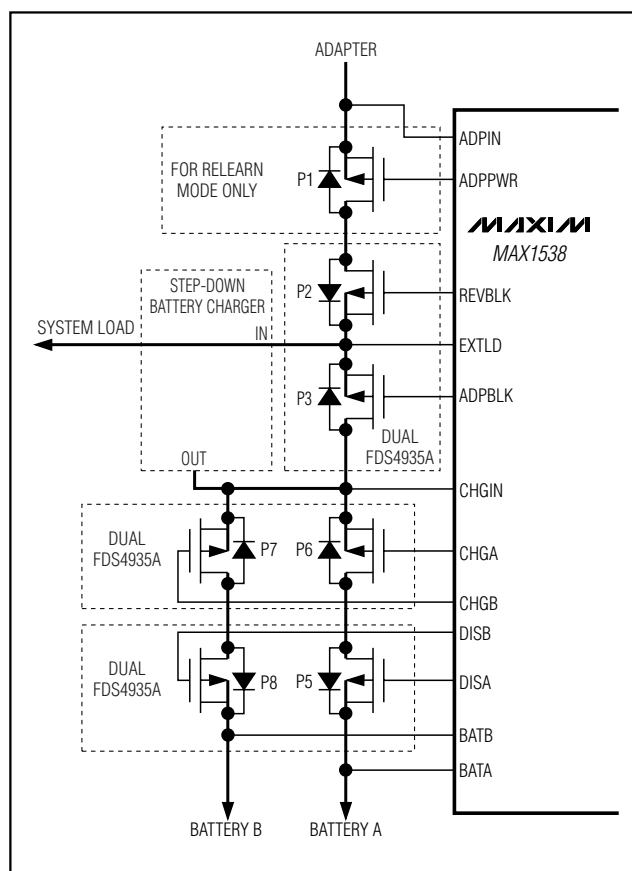

Figure 6. Optimal Use of Power Dissipation Using Dual MOSFETs

Power-Source Selector for Dual-Battery Systems

MOSFETs, they should be paired as shown in Figure 6 for optimal power dissipation.

The MAX1538 provides asymmetric MOSFET gate drive, typically turning MOSFETs on faster than they are turned off. The t_{TRANS} timer ensures that the MOSFETs that are turning on begin to turn on $10\mu s$ after those MOSFETs that are turning off begin to turn off. Choose MOSFETs with low enough gate charge that all off-transitioning MOSFETs turn off before any on-transitioning MOSFET turns on. Use the following equations to estimate the worst-case turn-on and turn-off times:

$$t_{ON} = \frac{Q_G}{V_G} \left(\frac{\Delta V_1}{I_{OFF1}} + \frac{\Delta V_2}{I_{OFF2}} \right) = \frac{Q_G}{V_G} \times 0.93k\Omega$$

$$t_{ON} = \frac{Q_G}{V_G} \times \frac{5V}{I_{ON}} = \frac{Q_G}{V_G} \times 0.25k\Omega$$

where t_{ON} is the turn-on time, t_{OFF} is the turn-off time, Q_G is the MOSFET's total gate charge specified at voltage V_G , I_{OFF1} is the 18mA (min) gate current when driving the gate from 7.5V gate drive to 2V gate drive, ΔV_1 is the voltage change during the 18mA gate drive (5.5V), I_{OFF2} is 3mA gate current when driving the gate from 2V to 0V, ΔV_2 is the 2V change, and I_{ON} is the turn-on current.

The MAX1538's gate-drive current is nonlinear and is a function of gate voltage. For example, the gate driver

slows down as the MOSFET approaches off. See the *Typical Operating Characteristics* for a scope shot showing MAX1538 turn-on and turn-off times when driving FDS6679 MOSFETs. The MAX1538 typically turns the FDS6679 on in $0.7\mu s$ and off in $1\mu s$.

Combining the MAX1538 with a Charger

To configure the MAX1538 for use with a step-down charger, use the circuit of Figure 7. Connect the charger's power input to EXTLD. Do not connect the charger's power input to ADPIN. This ensures that the charger does not bias ADPIN through its high-side MOSFET.

System Holdup Capacitor

C_{SYS} must be capable of sustaining the maximum system load during the transition time between source selection. Size the capacitor so that:

$$5 \times V_{MINV} - (t_{MINV} + t_{TRANS} + t_{ON}) \times \frac{I_{SYS_MAX}}{C_{SYS}} > V_{SYS_MIN}$$

where t_{MINV} is the battery undervoltage comparator delay, t_{TRANS} is the fixed time between switching MOSFETs off and switching MOSFETs on, t_{ON} is the time to turn a MOSFET on (see the *MOSFET Selection* section), V_{MINV} is the lower of V_{MINVA} and V_{MINVB} , I_{SYS_MAX} is the maximum system load, V_{SYS_MIN} is the minimum allowable system voltage before system

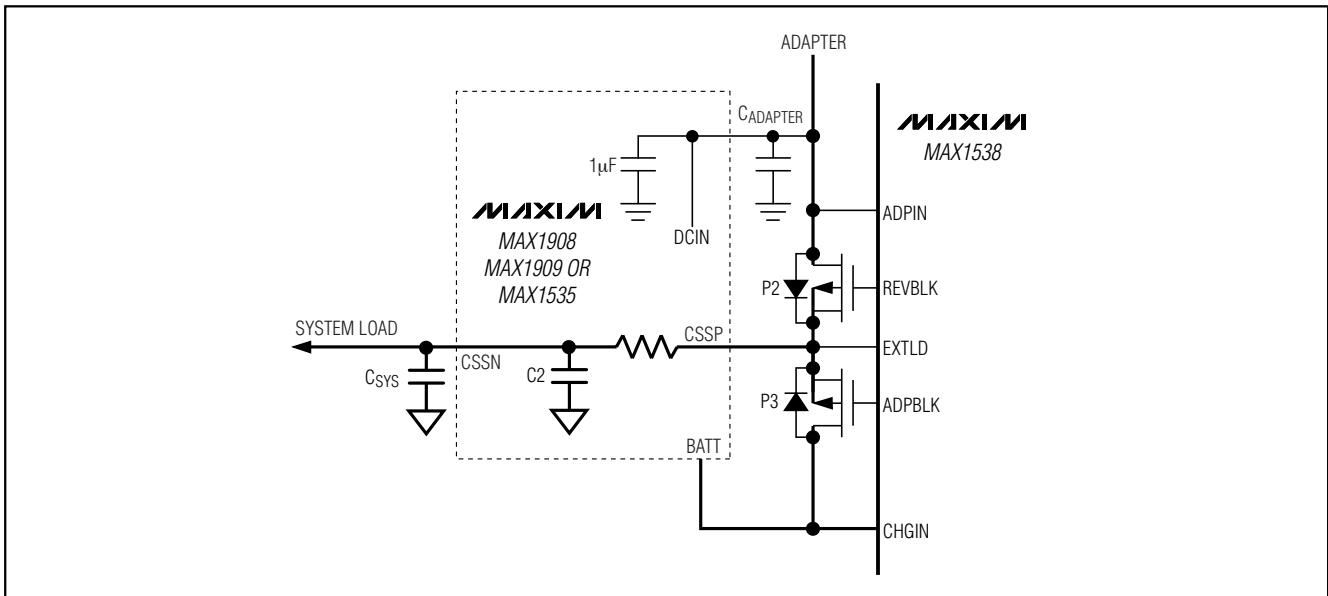

Figure 7. Combining the MAX1538 with a Charger

Power-Source Selector for Dual-Battery Systems

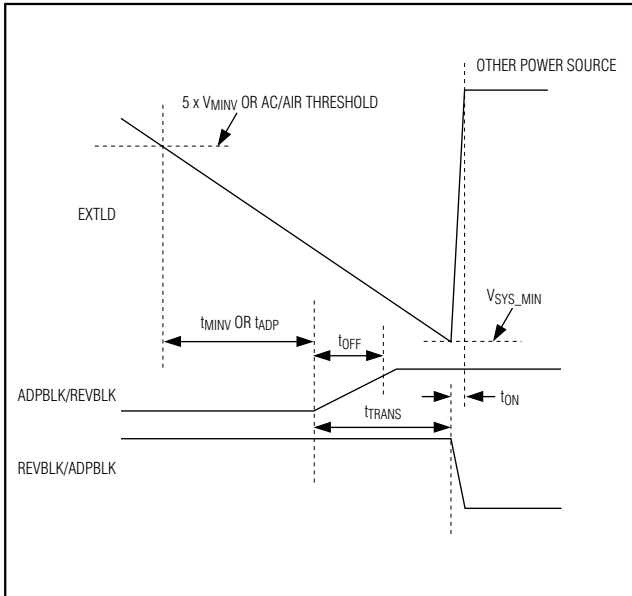

Figure 8. System Holdup Capacitor Timing

crash, and C_{SYS} is the total system holdup capacitance, which does not need to be near the MAX1538. The timing related to the system holdup capacitance is shown in Figure 8.

Charger output capacitance contributes to C_{SYS} for the step-down charger topology (Figure 1), but not for the step-up/step-down charger topology (Figure 2).

Leakage Current into BAT₋

Leakage current into BATA or BATB can interfere with proper battery-removal detection. D1 and D2 must be low leakage to ensure that battery removal is properly detected. Choose MOSFETs P6 and P7 with low off-leakage current. Board leakage current can also be a problem. For example, neighbor pins BATA and BATSUP should have greater than 50M Ω impedance between each other. Proper battery-removal detection requires that:

$$I_{Board} + I_{DS_OFF}(P6) + I_{DS_OFF}(P7) + I_{D1_leakage} + I_{D2_leakage} < I_{BAT_Sink@2V}$$

where I_{Board} is board leakage current, I_{DS_OFF} is the off-leakage current of MOSFETs P6 and P7, $I_{D_Leakage}$ is the reverse leakage current of the diodes, and $I_{BAT_Sink@2V}$ is the BAT₋ leakage current at 2V (0.4 μ A; see the *Typical Operating Characteristics*).

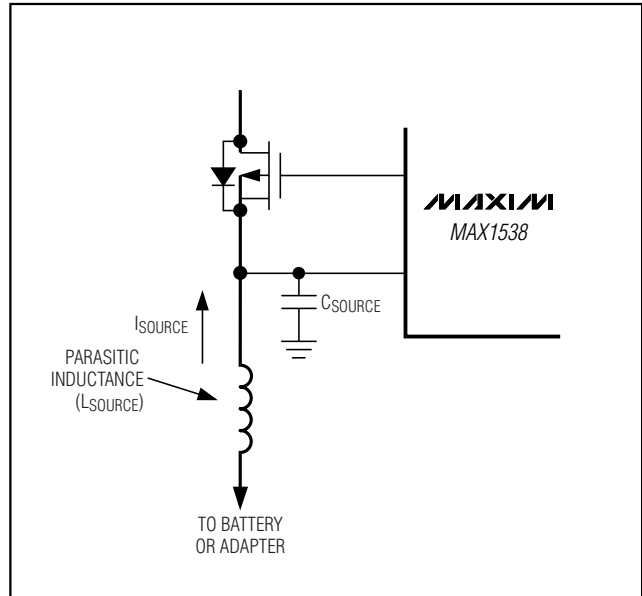

Figure 9. Inductive Kick Upon Source Disconnect

Inductive “Kick”

When the adapter or a battery is delivering a significant current to the system and that path is disabled (typically to enable another path), a voltage spike is generated at the source. This is due to a parasitic inductance shown in Figure 9. When the adapter is disconnected, a positive voltage spike occurs at ADP_{IN}. When a discharging battery is disconnected, a positive voltage spike occurs at BAT₋. Connect a capacitor from BAT₋ or ADP_{IN} to GND to limit this inductive kick. Choose the source capacitance according to the following equation:

$$C_{SOURCE} > \frac{L_{SOURCE} \times I_{SYS_MAX}^2}{30^2 - V_{SOURCE}^2}$$

where V_{SOURCE} is the maximum DC voltage of the source in question, I_{SYS_MAX} is the maximum system load, and L_{SOURCE} (parasitic inductance) and C_{SOURCE} are shown in Figure 9.

During battery charge, the voltage spike during battery disconnect is negative. To ensure that this negative voltage spike does not go below 0V, choose $C_{BAT_}$ according to the following equation:

$$C_{BAT_} > \frac{L_{BAT_} \times I_{CHG_MAX}^2}{V_{BAT_MIN}^2}$$

Power-Source Selector for Dual-Battery Systems

where V_{BAT_MIN} is the minimum battery voltage, I_{CHG_MAX} is the maximum charge current, and $L_{BAT_}$ is the battery's inductance. $C_{BAT_}$ values of $0.01\mu F$ are adequate for typical applications. Adding capacitance at $BAT_$ pins lengthens the time needed to detect battery removal. See the *Battery-Absence-Detection Delay* section.

Adapter Removal Debouncing

Upon adapter removal the adapter's connector may bounce. To avoid false detection of adapter reinsertion select R_1 , R_2 , and R_3 according to the following equation:

$$R_1 + R_2 + R_3 < \frac{V_{Threshold} \times t_{Bounce}}{C_{ADPIN} \times (V_{Adapter} - V_{Threshold})}$$

where $V_{Adapter}$ is the AC-adapter voltage when removing an AC adapter and airline-adapter voltage when removing an airline adapter, C_{ADPIN} is the capacitance at $ADPIN$, and t_{Bounce} is the 5ms debounce time. See the *Airline Mode and AC Adapter* section for a definition of $V_{Threshold}$.

Battery-Absence-Detection Delay

When a selected battery is removed, the system load quickly pulls $BAT_$ below $5 \times V_{MINV_}$ and another source is selected. The battery is considered present and undervoltage until $V_{BAT_}$ falls below 2V. Although another power source is quickly switched to the system load, capacitance at $BAT_$ (see the *Inductive "Kick"* section) delays the detection of the removed battery. If another battery is inserted before this delay has passed, it is considered undervoltage. Calculate the delay using the following equation:

$$t_{Absence_delay} = \frac{19V \times C_{BAT_}}{I_{BAT}}$$

where $I_{BAT_}$ is the $3.9\mu A$ $BAT_$ quiescent current (due to a $5M\Omega$ internal resistor), and $C_{BAT_}$ is the capacitance from $BAT_$ to GND. When $C_{BAT_} = 1\mu F$, $t_{Absence_delay}$ corresponds to a 5s time constant. If this time is unacceptable, use a smaller capacitance or connect a resistor or current sink from $BAT_$ to GND.

Layout

The MAX1538 selector fits in a very small layout. Ensure that C1 is placed close to V_{DD} and GND. Connect the paddle to GND directly under the IC. A complete layout example is shown in Figure 10.

Because BATA and BATB are high-impedance nodes, prevent leakage current between BATA/BATB and other high-voltage sources by carefully routing traces. Note that flux remaining on the board can significantly contribute to leakage current. See the *Leakage Current into BAT_* section.

Minimize parasitic inductance in the BATA and BATB path to reduce inductive kick during battery disconnect. This reduces the capacitance requirement at BATA and BATB.

Pin Configuration

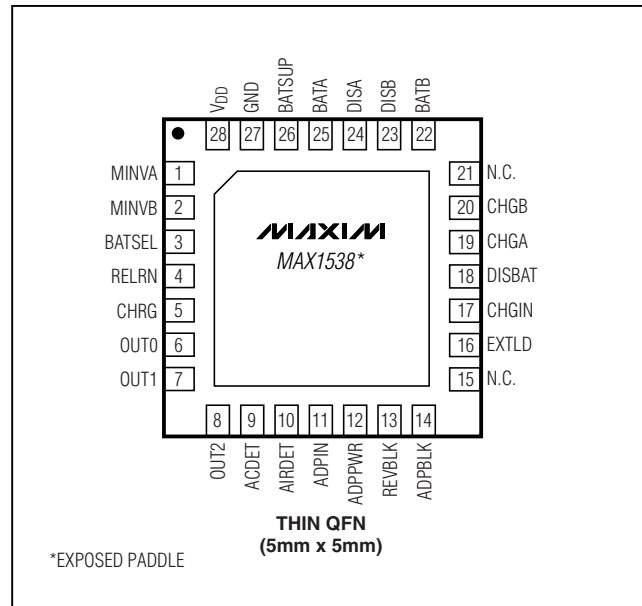

Chip Information

TRANSISTOR COUNT: 5431

PROCESS: BiCMOS

Power-Source Selector for Dual-Battery Systems

MAX1538

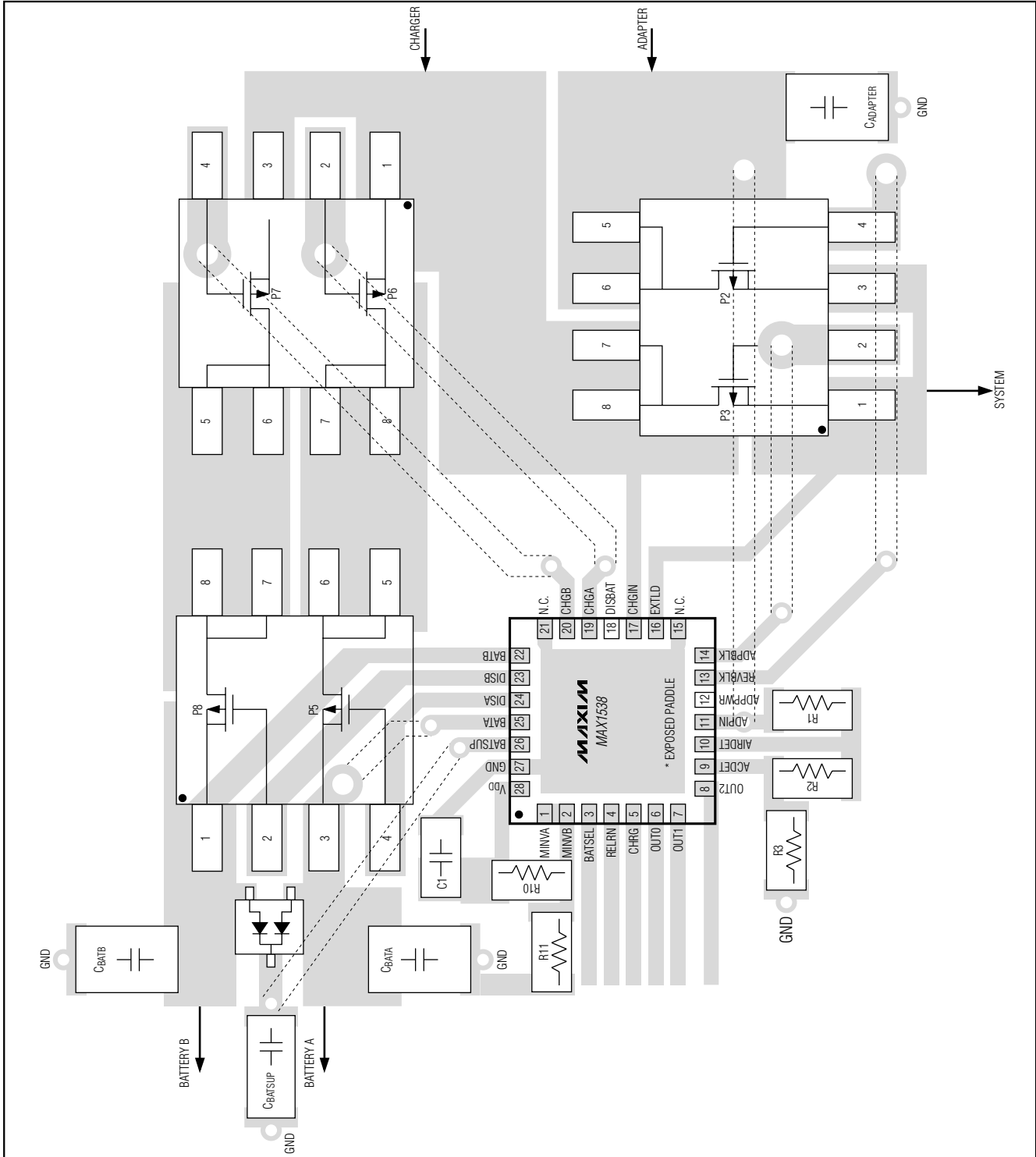
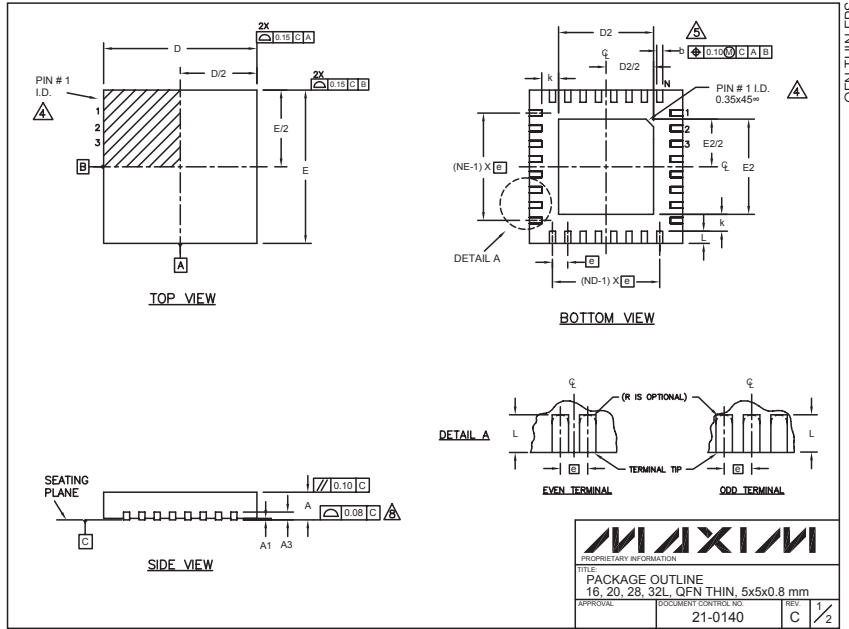

Figure 10. MAX1538 Layout Example

Power-Source Selector for Dual-Battery Systems

Package Information

(The package drawing(s) in this data sheet may not reflect the most current specifications. For the latest package outline information, go to www.maxim-ic.com/packages.)



COMMON DIMENSIONS												
PKG. SYMBOL	16L 5x5			20L 5x5			28L 5x5			32L 5x5		
	MIN.	NOM.	MAX.	MIN.	NOM.	MAX.	MIN.	NOM.	MAX.	MIN.	NOM.	MAX.
A	0.70	0.75	0.80	0.70	0.75	0.80	0.70	0.75	0.80	0.70	0.75	0.80
A1	0	0.02	0.05	0	0.02	0.05	0	0.02	0.05	0	0.02	0.05
A3	0.20 REF.			0.20 REF.			0.20 REF.			0.20 REF.		
b	0.25	0.30	0.35	0.25	0.30	0.35	0.20	0.25	0.30	0.20	0.25	0.30
D	4.90	5.00	5.10	4.90	5.00	5.10	4.90	5.00	5.10	4.90	5.00	5.10
E	4.90	5.00	5.10	4.90	5.00	5.10	4.90	5.00	5.10	4.90	5.00	5.10
e	0.80 BSC.			0.65 BSC.			0.50 BSC.			0.50 BSC.		
k	0.25	-	-	0.25	-	-	0.25	-	-	0.25	-	-
L	0.45	0.55	0.65	0.45	0.55	0.65	0.45	0.55	0.65	0.30	0.40	0.50
N	16			20			28			32		
ND	4			5			7			8		
NE	4			5			7			8		
JEDEC	WHHB			WHHC			WHHD-1			WHHD-2		

EXPOSED PAD VARIATIONS						
PKG. CODES	D2			E2		
	MIN.	NOM.	MAX.	MIN.	NOM.	MAX.
T1655-1	3.00	3.10	3.20	3.00	3.10	3.20
T2055-2	3.00	3.10	3.20	3.00	3.10	3.20
T2855-1	3.15	3.25	3.35	3.15	3.25	3.35
T2855-2	2.60	2.70	2.80	2.60	2.70	2.80
T3255-2	3.00	3.10	3.20	3.00	3.10	3.20

NOTES:

- DIMENSIONING & TOLERANCING CONFORM TO ASME Y14.5M-1994.
- ALL DIMENSIONS ARE IN MILLIMETERS. ANGLES ARE IN DEGREES.
- N IS THE TOTAL NUMBER OF TERMINALS.
- THE TERMINAL #1 IDENTIFIER AND TERMINAL NUMBERING CONVENTION SHALL CONFORM TO JEDEC 95-1 SPP-012. DETAILS OF TERMINAL #1 IDENTIFIER ARE OPTIONAL, BUT MUST BE LOCATED WITHIN THE ZONE INDICATED. THE TERMINAL #1 IDENTIFIER MAY BE EITHER A MOLD OR MARKED FEATURE.
- DIMENSION b APPLIES TO METALLIZED TERMINAL AND IS MEASURED BETWEEN 0.25 mm AND 0.30 mm FROM TERMINAL TIP.
- ND AND NE REFER TO THE NUMBER OF TERMINALS ON EACH D AND E SIDE RESPECTIVELY.
- DEPOPULATION IS POSSIBLE IN A SYMMETRICAL FASHION.
- COPLANARITY APPLIES TO THE EXPOSED HEAT SINK SLUG AS WELL AS THE TERMINALS.
- DRAWING CONFORMS TO JEDEC MO220.
- WARPAGE SHALL NOT EXCEED 0.10 mm.

Maxim cannot assume responsibility for use of any circuitry other than circuitry entirely embodied in a Maxim product. No circuit patent licenses are implied. Maxim reserves the right to change the circuitry and specifications without notice at any time.

22 **Maxim Integrated Products, 120 San Gabriel Drive, Sunnyvale, CA 94086 408-737-7600**

Mouser Electronics

Authorized Distributor

Click to View Pricing, Inventory, Delivery & Lifecycle Information:

[Maxim Integrated:](#)

[MAX1538ETI+](#) [MAX1538ETI+T](#)