

This document is the property of Amphenol Corporation and is delivered on the express condition that it is not to be disclosed, reproduced or used, in whole or in part, for manufacture or sale by anyone other than Amphenol Corporation without its prior consent, & that no right is granted to disclose or to use any information in this document.

# Customer drawing

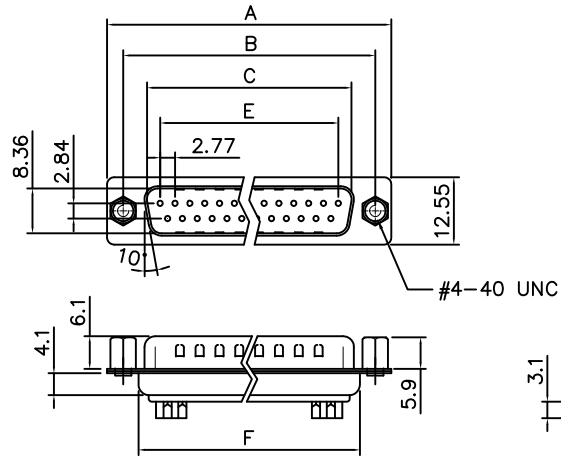

### Dimensions

Positions	A	B	C	E	F
9	30.81	24.99	16.92	11.08	19.20
15	39.20	33.30	25.25	19.39	27.70
25	53.04	47.04	38.96	33.24	41.10
37	69.40	63.50	55.42	49.86	57.30

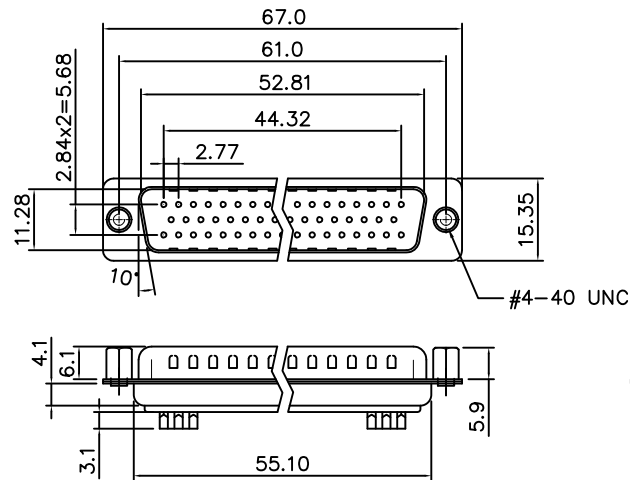

REVISIONS				
SYM	ECN	DESCRIPTION	DATE	APPROVED
1	HK--	First Release Drawing	09/19/14	IP

### D-SUB TECHNICAL DATA

SHELL : Steel 100u" tin over 50u" min nickel over 50u" min copper  
 BODY : Glass-Filled Thermoplastic PBT, UL94V-0  
 CONTACTS : Copper Alloy  
 Gold flash over 50u" min nickel on mating area  
 100u" min tin over 50u" min nickel on solder area  
 CLINCH NUT: Brass,Nickel Plated  
 ELECTRICAL: Voltage rating : 250 V Rms 60Hz  
 Current rating : 3A  
 Withstanding Voltage >1000 V Rms 60Hz for 1 minute  
 Insulation resistance >1000 M Ohms  
 Contact resistance 20 mOhms max.  
 MARKING : Amphenol...(Series No.)  
 Commercial reference  
 Manufacturing date

### PRODUCT CODE

L 717 SD X XX P VF

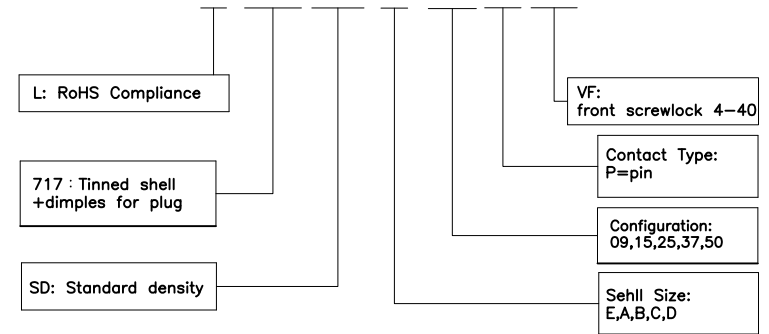

UNLESS OTHERWISE SPECIFIED TOLERANCES U.S. METRIC X. +/- 0.50 .X +/- 0.30 .XX +/- 0.20 FRACTIONS +/- ANGLES +/- 5° FOR MATERIALS AND FINISHES SEE NOTES REMOVE SHARP EDGES DIMENSIONS U.S. INCHES METRIC MM	APPROVAL	DATE
	DRAWN <i>Felix Liu</i>	09/19/14
	CHECKED <i>Tony Tang</i>	09/19/14
	CHECKED	
DRAWING FILE :	ANGLE OF PROJECTION	

Amphenol	
Amphenol East Asia Limited	
TITLE Stamped and formed contact,SD series	
SIZE	DRAWING NO.
A4	L717SDXXXPVF
SCALE	NONE
SHEET	1 OF 1
REV.	1