

Description

The PAM2841 is a white LED driver, capable of driving 10 or more WLEDs in series (depending on forward voltage of the LEDs) with a range of input voltages from 2.7V to 5.5V.

The PAM2841 features over current protection, over voltage protection, under voltage lockout and over temperature protection, which prevent the device from damage.

LED dimming can be done by four methods as described in the Application Information hereinafter.

Features

- Capable of Driving 10 or More WLEDs
- Chip Enable with Soft-Start
- Analog and PWM Dimming
- Peak Efficiency up to 90%
- Low Quiescent Current
- Fixed Frequency of 1MHz
- Over Current Protection
- Over Voltage Protection
- Thermal Protection
- UVLO
- **Totally Lead-Free & Fully RoHS Compliant (Notes 1 & 2)**
- **Halogen and Antimony Free. "Green" Device (Note 3)**

Applications

- WLED Driver System

Pin Assignments

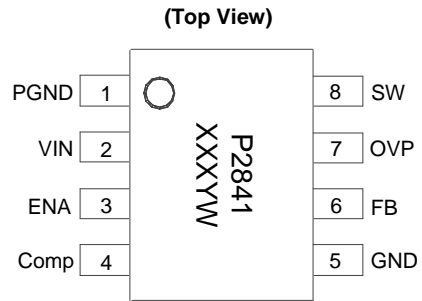

MSOP-8

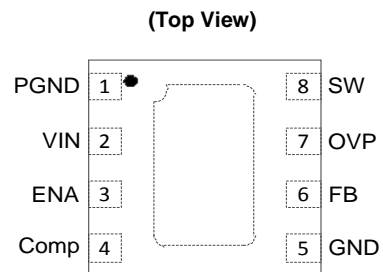

U-DFN2020-8 (Type A)

- Notes:
1. No purposely added lead. Fully EU Directive 2002/95/EC (RoHS) & 2011/65/EU (RoHS 2) compliant.
 2. See http://www.diodes.com/quality/lead_free.html for more information about Diodes Incorporated's definitions of Halogen- and Antimony-free, "Green" and Lead-free.
 3. Halogen- and Antimony-free "Green" products are defined as those which contain <900ppm bromine, <900ppm chlorine (<1500ppm total Br + Cl) and <1000ppm antimony compounds.

Typical Applications Circuit

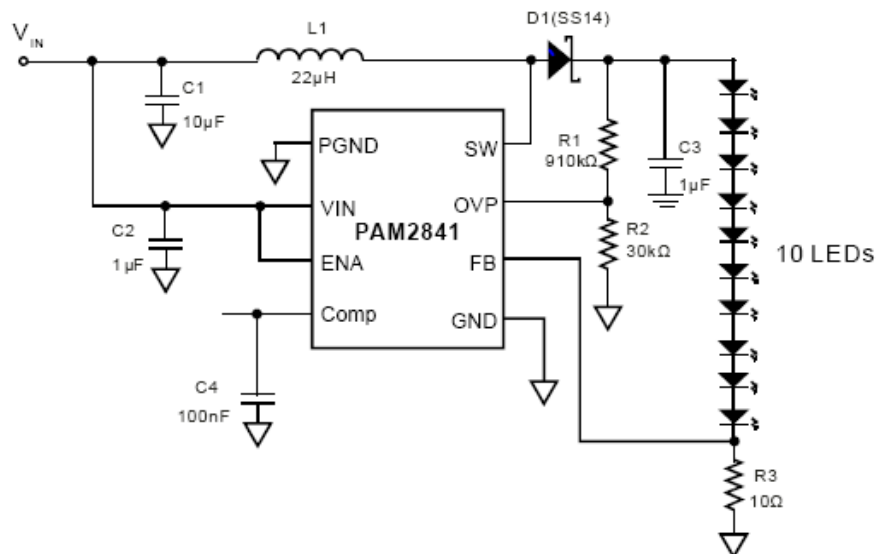

Typical Applications Circuit (Cont.)

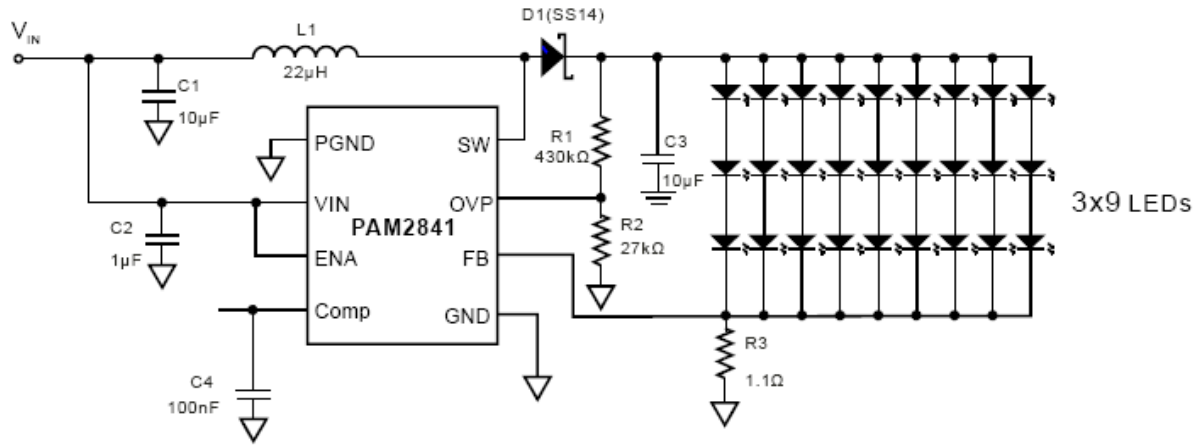

Pin Descriptions

Pin Number	Pin Name	Function
1	PGND	Power Ground
2	VIN	Input Voltage
3	ENA	Chip Enable, Active High
4	Comp	Compensation Node
5	GND	Chip Ground
6	FB	Feedback
7	OVP	Over Voltage
8	SW	Drain of Main Switch

Functional Block Diagram

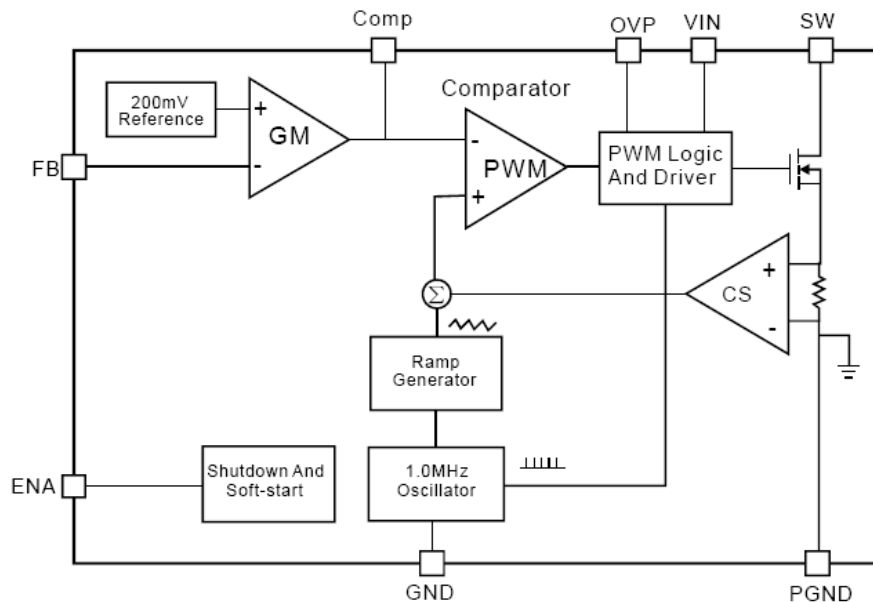

Absolute Maximum Ratings (@T_A = +25°C, unless otherwise specified.)

These are stress ratings only and functional operation is not implied. Exposure to absolute maximum ratings for prolonged time periods may affect device reliability. All voltages are with respect to ground.

Parameter	Rating	Unit
Supply Voltage	6.0	V
I/O Pins Voltage Range	GND - 0.3 to V _{DD} + 0.3	
Maximum SW Pin Voltage	40	
Storage Temperature	-65 to +170	°C
Maximum Junction Temperature	+170	
Soldering Temperature	+300, 5sec	

Recommended Operating Conditions (@T_A = +25°C, unless otherwise specified.)

Parameter	Rating	Unit
Supply Voltage Range	2.8 to 5.5	V
Operation Temperature Range	-40 to +85	°C
Junction Temperature Range	-40 to +150	

Thermal Information

Parameter	Package	Symbol	Max	Unit
Thermal Resistance (Junction to Ambient)	MSOP-8	θ _{JA}	180	°C/W
	U-DFN2020-8 (Type A)		80	
Thermal Resistance (Junction to Case)	MSOP-8	θ _{JC}	75	
	U-DFN2020-8 (Type A)		30	

Electrical Characteristics (@ $T_A = +25^\circ\text{C}$, $V_{EN} = V_{DD} = 5.0\text{V}$, 10 LEDs, unless otherwise specified.)

Symbol	Parameter	Test Conditions	Min	Typ	Max	Unit
V_{DD}	Supply Voltage Range	—	2.7	—	5.5	V
I_Q	Quiescent Current	No Switching	—	200	300	μA
I_{SD}	Shutdown Current	$V_{ENA} = \text{Low}$	—	—	1	μA
I_O	Output Current	$R_3 = 5.1\Omega$	—	40	—	mA
		$R_3 = 6.8\Omega$	—	30	—	
		$R_3 = 10\Omega$	—	20	—	
		$R_3 = 20\Omega$	—	10	—	
V_O	Output Voltage Range	—	$V_{IN} \times 1.1$	—	40	V
V_{FB}	Feedback Voltage	$V_{ENA} = \text{High}$	194	200	206	mV
$R_{DS(ON)}$	SW On-Resistance	$I_{SW} = 100\text{mA}$	—	0.35	0.5	Ω
I_{LIM}	SW Current Limit	Switch On	—	1.5	—	A
f_{SW}	SW Frequency	—	0.7	1.0	1.3	MHz
DC	Maximum Duty Cycle	—	—	95	—	%
OVP	Over Voltage Protection Threshold	Open Load	—	1.2	—	V
V_{EL}	Enable Threshold Voltage	Chip Shutdown	—	—	0.4	V
V_{EH}		Chip On	1.2	—	—	
UVLO	Under Voltage Lockout	V_{IN} Falling	2.0	2.2	2.4	V
V_{TH}	UVLO Hysteresis	—	—	0.2	—	V
OTS	Over Temperature Shutdown	—	—	+150	—	$^\circ\text{C}$
OTH	Over Temperature Hysteresis	—	—	+30	—	$^\circ\text{C}$

Typical Performance Characteristics (@ $T_A = +25^\circ\text{C}$, $V_{DD} = 5\text{V}$, unless otherwise specified.)

1. Efficiency VS Input Voltage

$I_{LED} = 20\text{mA}$, $L = 22\mu\text{H}$

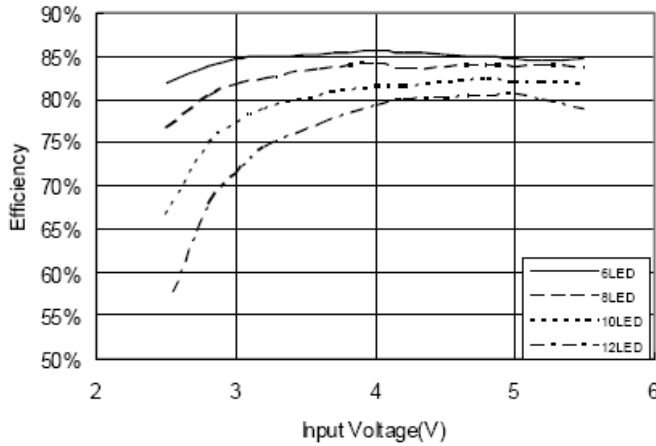

2. Efficiency VS Load Current

6 LED, $L = 22\mu\text{H}$

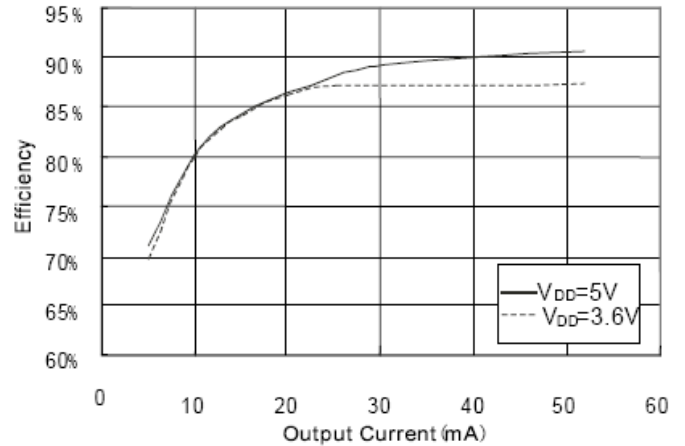

3. Efficiency VS Input Voltage

$I_{LED} = 20\text{mA}$, 10 LED

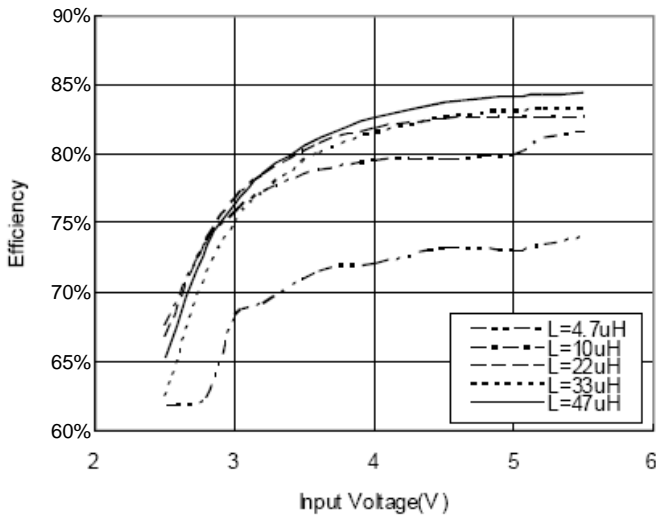

4. LED Current VS Output Voltage

$L = 47\mu\text{H}$

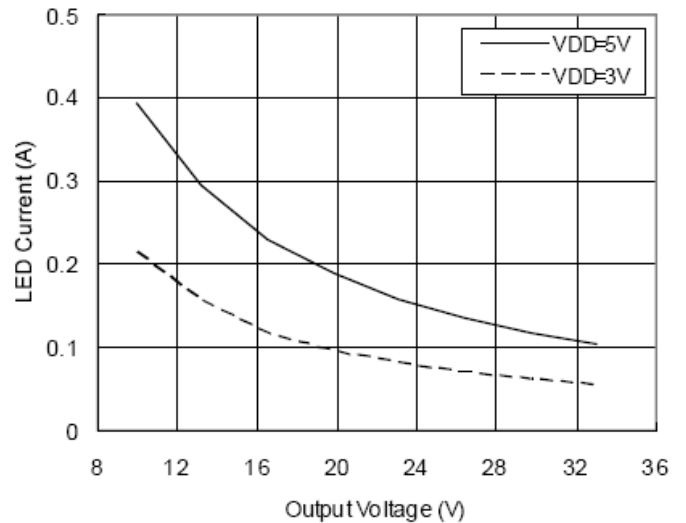

Typical Performance Characteristics (Cont.) (@ $T_A = +25^\circ\text{C}$, $V_{DD} = 5\text{V}$, unless otherwise specified.)

5. Feedback Voltage VS Input voltage
10 LED, $I_{LED} = 20\text{mA}$

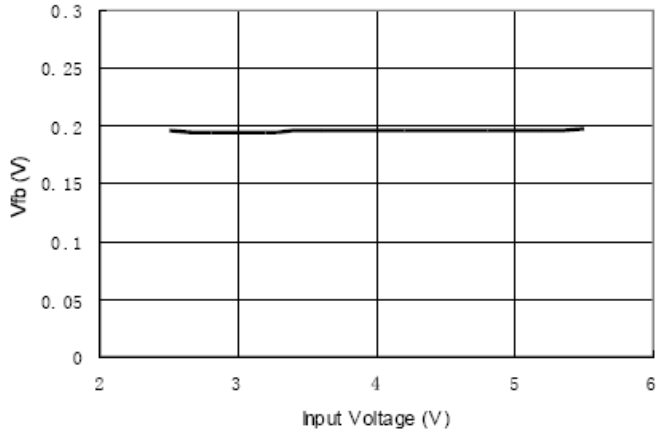

6. Feedback Voltage VS Temperature
10 LED, $I_{LED} = 20\text{mA}$

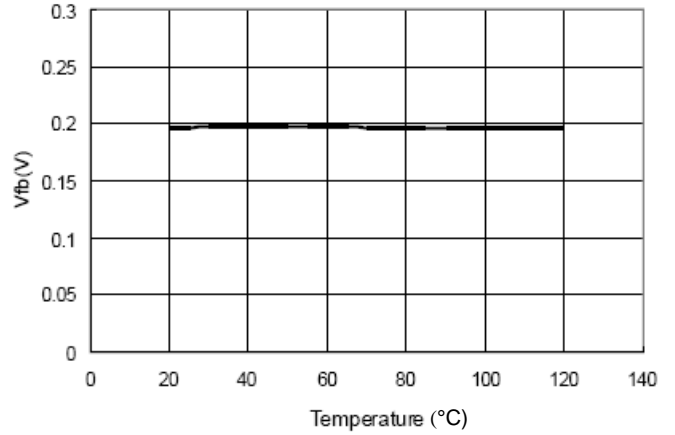

7. LED current VS Input voltage
 $L = 22\mu\text{H}$, 10 LED

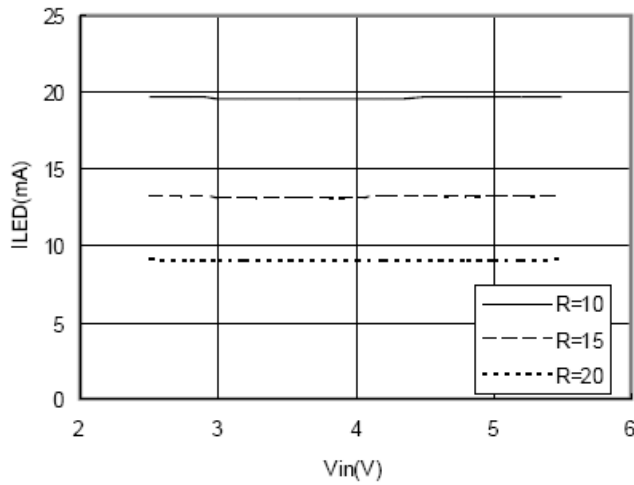

8. Frequency VS Input Voltage
10 LED

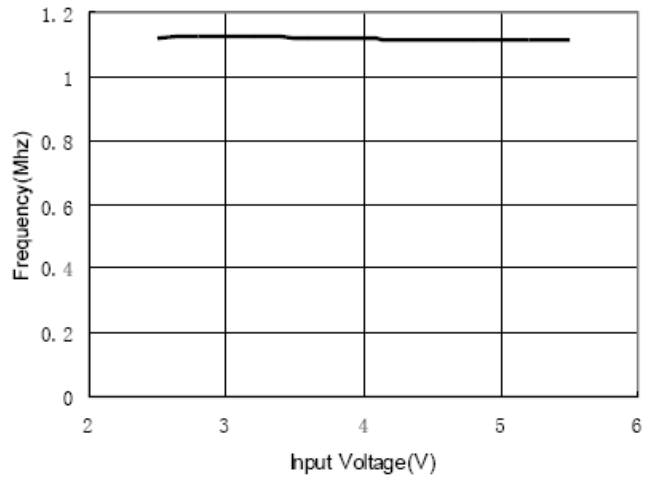

Typical Performance Characteristics (Cont.) (@ $T_A = +25^\circ\text{C}$, $V_{DD} = 5\text{V}$, unless otherwise specified.)

9. Quiescent Current VS Input Voltage

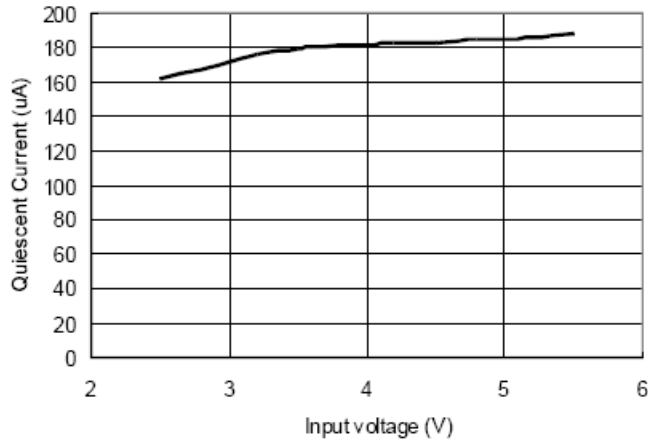

10. Frequency VS Temperature
(10 LED, $I_{LED} = 20\text{mA}$)

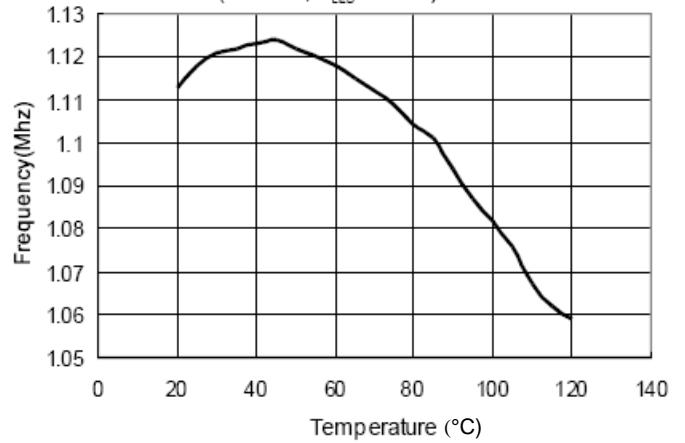

11. LED Current VS Duty Cycle of PWM
PWM @ ENA Pin

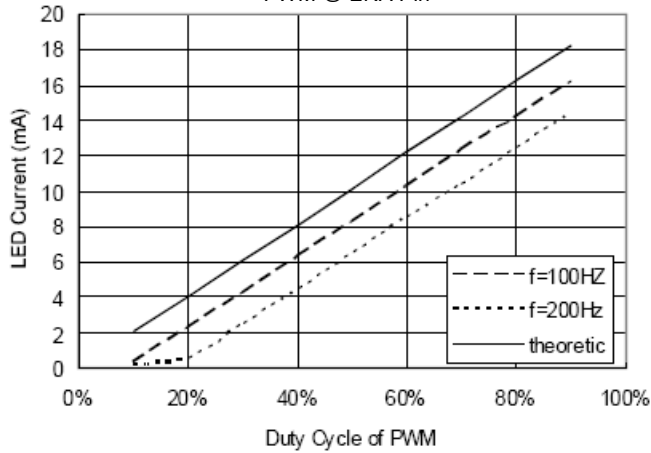

12. LED Current VS Duty Cycle of PWM
PWM @ Comp Pin

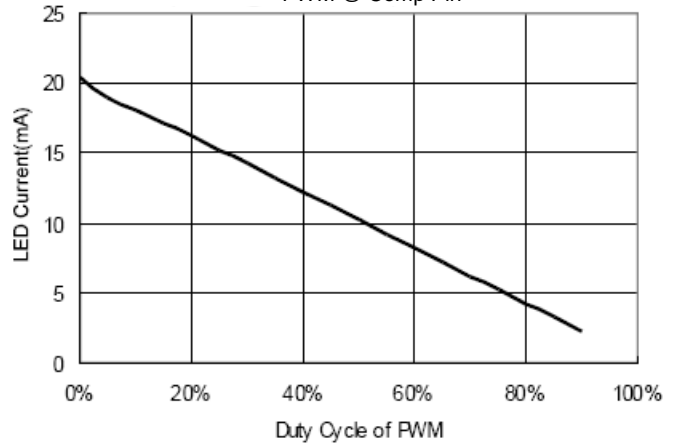

Typical Performance Characteristics (Cont.) (@ $T_A = +25^\circ\text{C}$, $V_{DD} = 5\text{V}$, unless otherwise specified.)

13. Start-up Waveform
 $V_{in}=5\text{V}$, 10LED, $I_{led}=20\text{mA}$

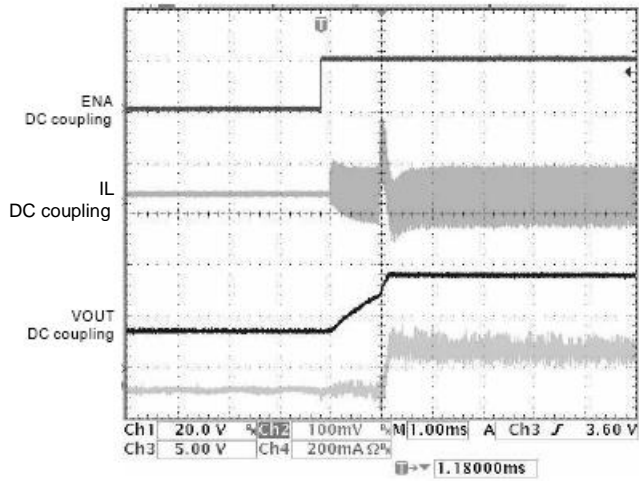

14. Steady State Waveform
 $V_{in}=5\text{V}$, 10LED, $I_{led}=20\text{mA}$

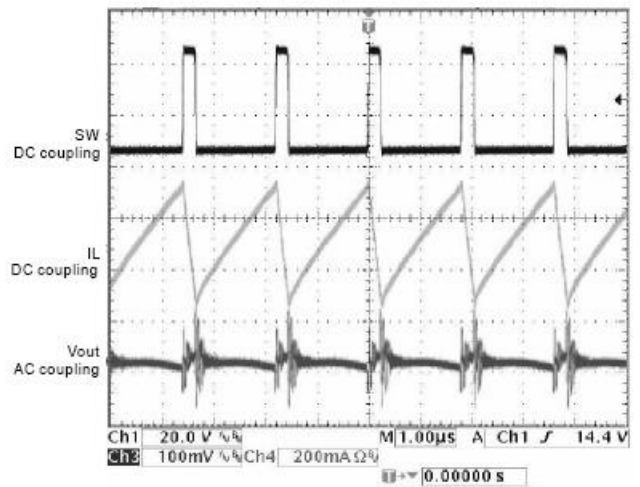

15. Open load

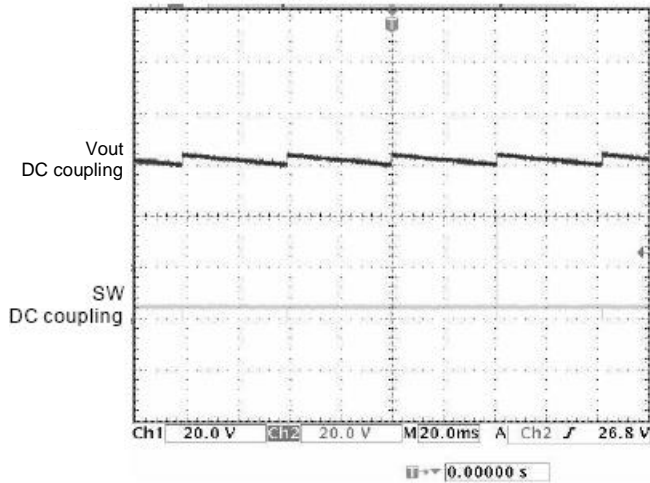

16. Open load

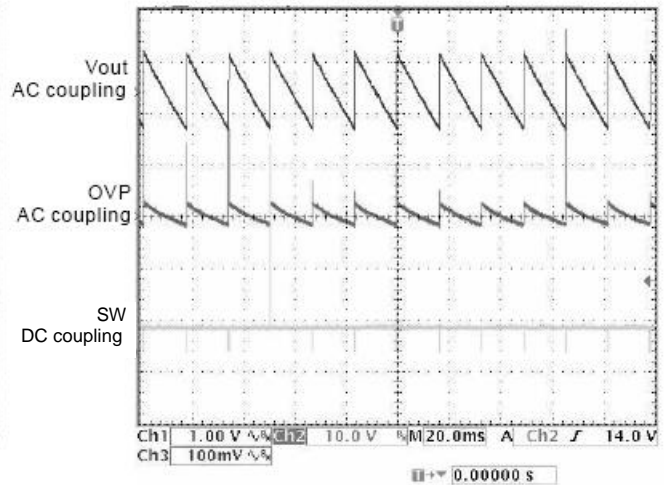

Application Information

Inductor Selection

The selection of the inductor affects steady state operation as well as transient behavior and loop stability. These factors make it the most important component in power regulator design. There are three important inductor specifications, inductor value, DC resistance and saturation current. Considering inductor value alone is not enough.

The inductor value determines the inductor ripple current. Choose an inductor that can handle the necessary peak current without saturation, the inductor DC current given by:

$$I_{IN_DC} = V_{OUT} * I_{OUT} / (V_{IN} * \eta) \quad \eta = \text{efficiency.}$$

Inductor values can have $\pm 20\%$ tolerance with no current bias. When the inductor current approaches saturation level, its inductance can decrease 20% to 35% from the 0A value depending on how the inductor vendor defines saturation current. Using an inductor with a smaller inductance value causes discontinuous PWM when the inductor current ramps down to zero before the end of each switching cycle. This reduces the boost converter's maximum output current, causes large input voltage ripple and reduces efficiency. Large inductance value provides much more output current and higher conversion efficiency. For these reasons, an inductor within 4.7 μ H to 22 μ H value range is recommended.

Schottky Diode Selection

The high switching frequency of the PAM2841 demands a high-speed rectification for optimum efficiency. Ensure that the diode average and peak current rating exceeds the average output current and peak inductor current. In addition, the diode's reverse breakdown voltage must exceed the open protection voltage.

Input and Output Capacitor Selection

Input Capacitor

At least a 1 μ F input capacitor is recommended to reduce the input ripple and switching noise for normal operating conditions. Larger value and lower ESR (Equivalent Series Resistance) may be needed if the application require very low input ripple. It follows that ceramic capacitors are a good choice for applications. Note that the input capacitor should be located as close as possible to the device.

Output Capacitor

The output capacitor is mainly selected to meet the requirement for the output ripple and loop stability. This ripple voltage is related to the capacitor's capacitance and its equivalent series resistance (ESR). A output capacitor of 1 μ F minimum is recommended and maybe need a larger capacitor. The total output voltage ripple has two components: the capacitive ripple caused by the charging and discharging on the output capacitor, and the ohmic ripple due to the capacitor's equivalent series resistance (ESR):

$$V_{RIPPLE} = V_{RIPPLE(C)} + V_{RIPPLE(ESR)}$$

$$V_{RIPPLE(C)} \approx \frac{1}{2} * (L / C_{OUT} * ((V_{OUT(MAX)} - V_{IN(MIN)}))) * (I_{PEAK}^2 - I_{OUT}^2)$$

$$V_{RIPPLE(ESR)} = I_{PEAK} * R_{ESR(COUT)}$$

Where I_{PEAK} is the peak inductor current.

Multilayer ceramic capacitors are an excellent choice as they have extremely low ESR and are available in small footprints. Capacitance and ESR variation with temperature should be considered for best performance in applications with wide operating temperature ranges.

Dimming Control

There are 4 different types of dimming control methods:

1. Using an External PWM Signal to ENA Pin

With the PWM signal applied to the ENA pin, the PAM2841 is alternately turned on or off by the PWM signal. The LEDs operate at either zero or full current. The average LED current changes proportionally with the duty cycle of the PWM signal. A 0% duty cycle turns off the PAM2841 and leads to zero LED current. A 100% duty cycle generates full current. Also the recommend dimming frequency is between 100Hz and 200Hz.

$$I_{AVE} = I_{STATE} * (t_{ON} - t_{STARTUP}) / (t_{ON} + t_{OFF})$$

Where t_{ON} : on time of a period

$t_{STARTUP}$: 0.85ms

t_{OFF} : off time of a period

I_{STATE} : on state current (full current)

Application Information (Cont.)

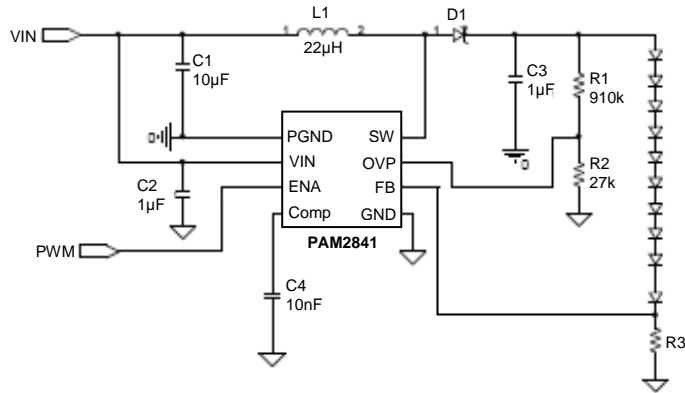

Figure 1

2. Using an External PWM Signal to NMOS Gate

When PWM signal is at high level, N MOSFET turned on, then pull Comp pin down, then the LED current should be zero. When PWM signal is at low level, N MOSFET turned off. The circuit uses resistor R1 to set the on state current. The average LED current changes proportionally with the duty cycle of the PWM signal. A 100% duty cycle turns off the PAM2841 and leads to zero LED current. A 0% duty cycle generates full current.

$$I_{AVE} = I_{STATE} * (t_{ON} - t_{STARTUP}) / (t_{ON} + t_{OFF})$$

Where t_{ON} : on time of a period

$t_{STARTUP}$: 0.08ms

t_{OFF} : off time of a period

I_{STATE} : on state current (full current)

Also the recommend frequency is between 100 and 500Hz. Frequency < 100Hz can naturally cause LEDs to blink visibly.

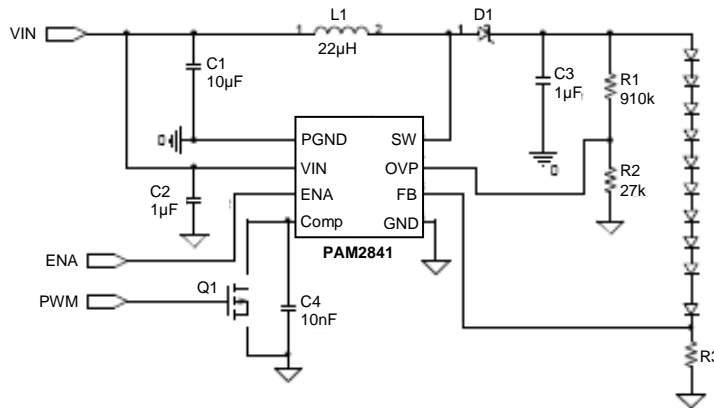

Figure 2

3. Using a DC Voltage

For some applications, a simple and direct way to control brightness is using an external variable DC voltage to vary the voltage drop on feedback resistor. This will make the PAM2841 adjust the output current to follow the change of feedback voltage. The circuit is shown in Figure 3. As the DC voltage increases, the voltage drop on R4 increases and the voltage drop on R3 decreases. Thus, the LED current decreases. The selection of R4 and R5 will make the current from the variable DC source much smaller than the LED current and much larger than the FB pin current. For VCC range from 0V to 2V, the selection of resistors in Figure 3 gives dimming control of LED current from 0mA to 20mA.

Application Information (Cont.)

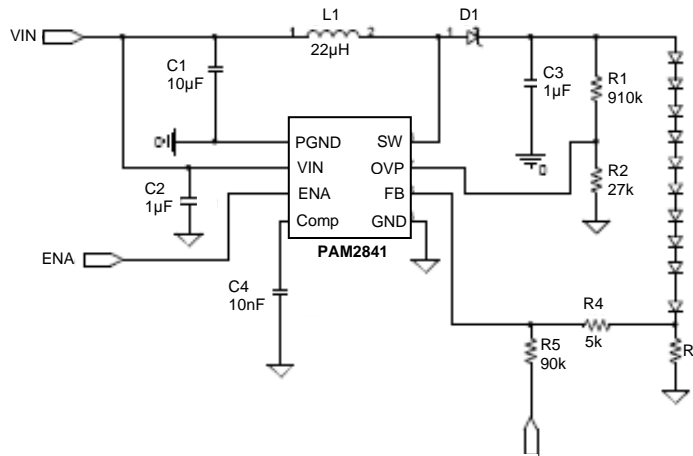

Figure 3

4. Using a Filtered PWM Signal

The filtered PWM signal can be considered as an adjustable DC voltage. Such regulated signal is often with some grade of ripple because of some simple configuration of circuit. With appropriated arrangement of PWM frequency and level, and filter parameters, it can be used to replace the variable DC voltage source in dimming control.

The circuit is shown in Figure 4.

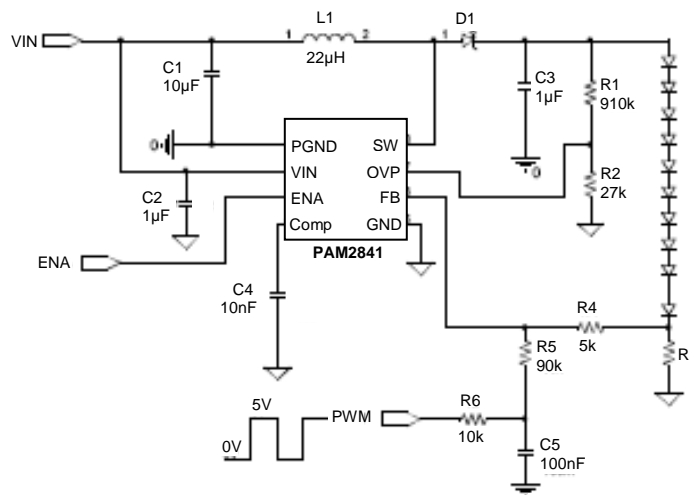

Figure 4

Layout Consideration

As for all switching power supplies, especially those in high frequency and high current ones, layout is an important design step. If layout is not carefully done, the regulator could suffer from instability as well as noise problems.

1. Use separate traces for power ground and signal ground. Power ground and signal ground are connected together to a quiet ground (input connector).
2. To prevent radiation of high frequency resonance, proper layout of the high frequency switching path is essential. Minimize the length and area of all traces connecting to the SW pin. The loop including the PWM switch, Schottky diode and output capacitor, contains high current rising and falling in nanosecond and thus it should be kept as short as possible.
3. The input capacitor should be close to both the VIN pin and the GND pin in order to reduce the IC supply ripple.
4. Keep the signal ground traces short and as close to the IC as possible. Small signal components should be placed as close as possible to the IC, thus minimizing control signal noise interference.

Application Information (Cont.)

Layout Example

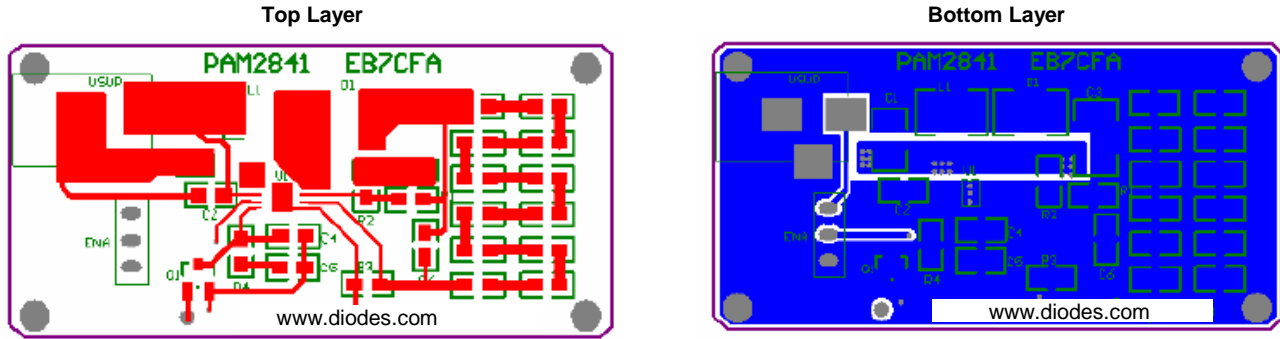

Ordering Information

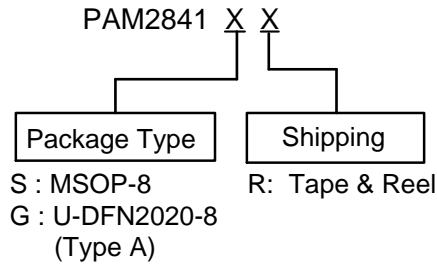

Part Number	Package Type	Standard Package
PAM2841SR	MSOP-8	2500 Units/Tape & Reel
PAM2841GR	U-DFN2020-8 (Type A)	3000 Units/Tape & Reel

Marking Information

(1) MSOP-8

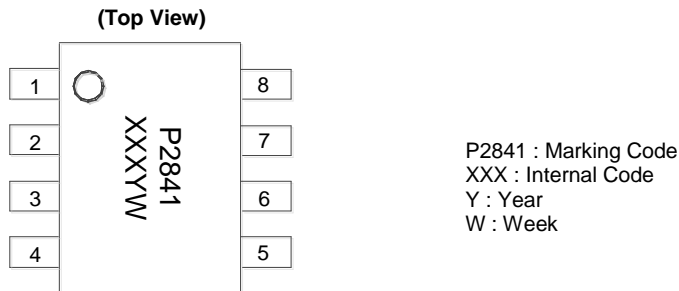

(2) U-DFN2020-8 (Type A)

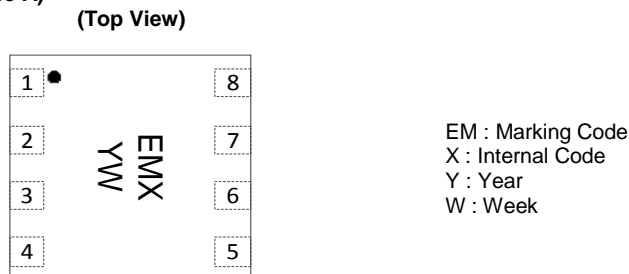

Package Outline Dimensions

Please see <http://www.diodes.com/package-outlines.html> for the latest version.

(1) MSOP-8

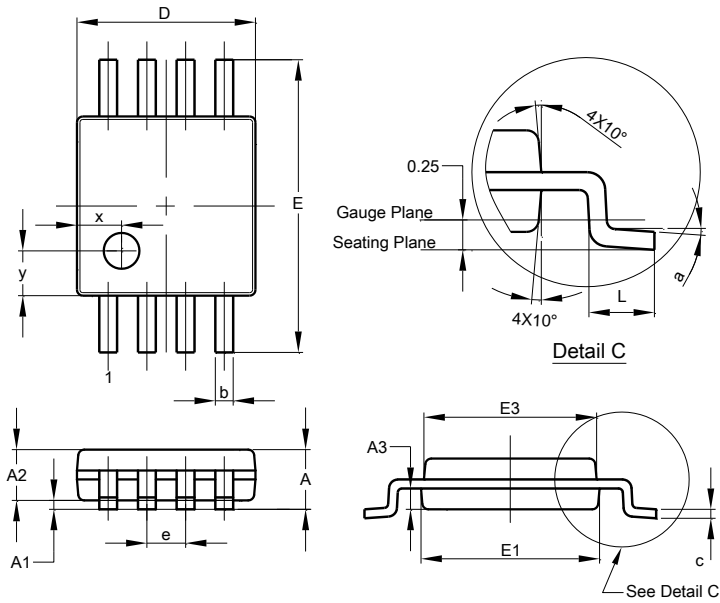

MSOP-8			
Dim	Min	Max	Typ
A	-	1.10	-
A1	0.05	0.15	0.10
A2	0.75	0.95	0.86
A3	0.29	0.49	0.39
b	0.22	0.38	0.30
c	0.08	0.23	0.15
D	2.90	3.10	3.00
E	4.70	5.10	4.90
E1	2.90	3.10	3.00
E3	2.85	3.05	2.95
e	-	-	0.65
L	0.40	0.80	0.60
a	0°	8°	4°
x	-	-	0.750
y	-	-	0.750
All Dimensions in mm			

(2) U-DFN2020-8 (Type A)

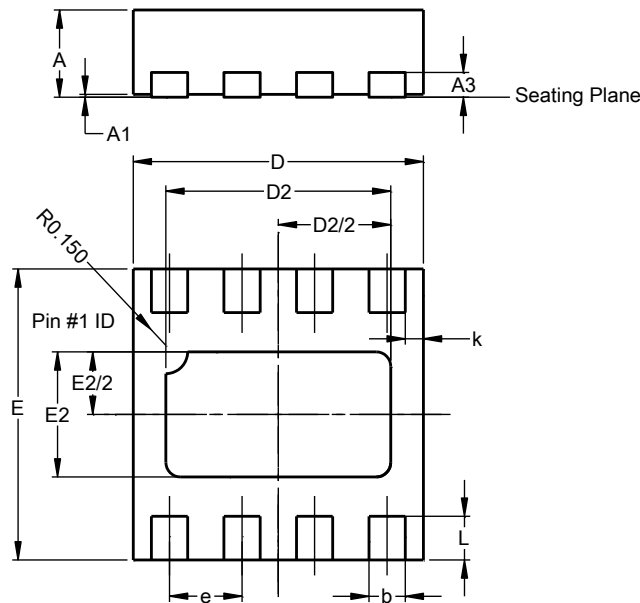

U-DFN2020-8 (Type A)			
Dim	Min	Max	Typ
A	0.570	0.630	0.600
A1	0	0.05	0.02
A3	-	-	0.152
b	0.20	0.30	0.25
D	1.950	2.075	2.00
D2	1.45	1.65	1.55
e	0.500 BSC		
E	1.950	2.075	2.00
E2	0.76	0.96	0.86
k	-	-	0.125
L	0.250	0.350	0.300
All Dimensions in mm			

NEW PRODUCT

Suggested Pad Layout

Please see <http://www.diodes.com/package-outlines.html> for the latest version.

(1) MSOP-8

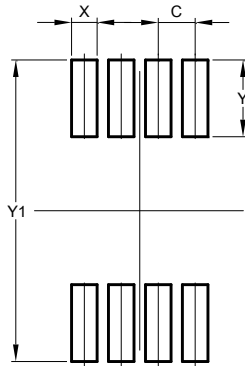

Dimensions	Value (in mm)
C	0.650
X	0.450
Y	1.350
Y1	5.300

(2) U-DFN2020-8 (Type A)

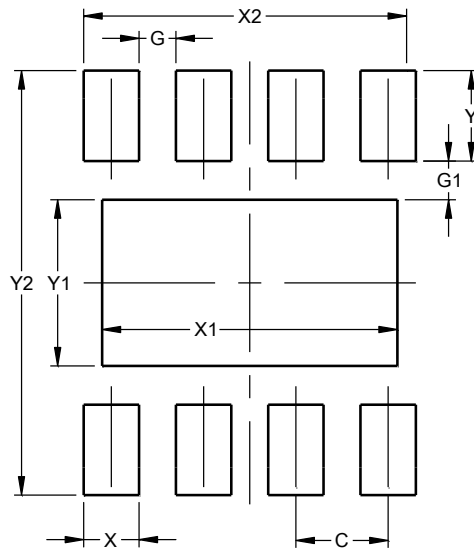

Dimensions	Value (in mm)
C	0.500
G	0.200
G1	0.210
X	0.300
X1	1.600
X2	1.750
Y	0.490
Y1	0.900
Y2	2.300

NEW PRODUCT

IMPORTANT NOTICE

DIODES INCORPORATED MAKES NO WARRANTY OF ANY KIND, EXPRESS OR IMPLIED, WITH REGARDS TO THIS DOCUMENT, INCLUDING, BUT NOT LIMITED TO, THE IMPLIED WARRANTIES OF MERCHANTABILITY AND FITNESS FOR A PARTICULAR PURPOSE (AND THEIR EQUIVALENTS UNDER THE LAWS OF ANY JURISDICTION).

Diodes Incorporated and its subsidiaries reserve the right to make modifications, enhancements, improvements, corrections or other changes without further notice to this document and any product described herein. Diodes Incorporated does not assume any liability arising out of the application or use of this document or any product described herein; neither does Diodes Incorporated convey any license under its patent or trademark rights, nor the rights of others. Any Customer or user of this document or products described herein in such applications shall assume all risks of such use and will agree to hold Diodes Incorporated and all the companies whose products are represented on Diodes Incorporated website, harmless against all damages.

Diodes Incorporated does not warrant or accept any liability whatsoever in respect of any products purchased through unauthorized sales channel. Should Customers purchase or use Diodes Incorporated products for any unintended or unauthorized application, Customers shall indemnify and hold Diodes Incorporated and its representatives harmless against all claims, damages, expenses, and attorney fees arising out of, directly or indirectly, any claim of personal injury or death associated with such unintended or unauthorized application.

Products described herein may be covered by one or more United States, international or foreign patents pending. Product names and markings noted herein may also be covered by one or more United States, international or foreign trademarks.

This document is written in English but may be translated into multiple languages for reference. Only the English version of this document is the final and determinative format released by Diodes Incorporated.

LIFE SUPPORT

Diodes Incorporated products are specifically not authorized for use as critical components in life support devices or systems without the express written approval of the Chief Executive Officer of Diodes Incorporated. As used herein:

A. Life support devices or systems are devices or systems which:

1. are intended to implant into the body, or
2. support or sustain life and whose failure to perform when properly used in accordance with instructions for use provided in the labeling can be reasonably expected to result in significant injury to the user.

B. A critical component is any component in a life support device or system whose failure to perform can be reasonably expected to cause the failure of the life support device or to affect its safety or effectiveness.

Customers represent that they have all necessary expertise in the safety and regulatory ramifications of their life support devices or systems, and acknowledge and agree that they are solely responsible for all legal, regulatory and safety-related requirements concerning their products and any use of Diodes Incorporated products in such safety-critical, life support devices or systems, notwithstanding any devices- or systems-related information or support that may be provided by Diodes Incorporated. Further, Customers must fully indemnify Diodes Incorporated and its representatives against any damages arising out of the use of Diodes Incorporated products in such safety-critical, life support devices or systems.

Copyright © 2017, Diodes Incorporated

www.diodes.com

Mouser Electronics

Authorized Distributor

Click to View Pricing, Inventory, Delivery & Lifecycle Information:

[Diodes Incorporated:](#)

[PAM2841GR](#) [PAM2841SR](#)