

### CST-1015

#### Description:

Triad current sense transformers are used to detect the current passing through a conductor. These transformers are very reliable and operate efficiently at 50/60 Hz.

#### Electrical Specifications (@25C)

IP Amps	Turns Ratio	Terminating Resistor		DCR (Ω) Nominal	Volts/Amp@ rated IP for various loads (Ω)				Net Weight Grams
		Ohms	Watts		100	500	2K	5K	
15	1000:1	100	.023	40	.0971	.4429	.7508	.9439	20

#### Dimensions:

A	B	C	D	E	F
23.50	24.80	12.00	15.00	7.50	8.50

Units: In mm

#### Response Curve:

Vout vs Input current (100Ω load)

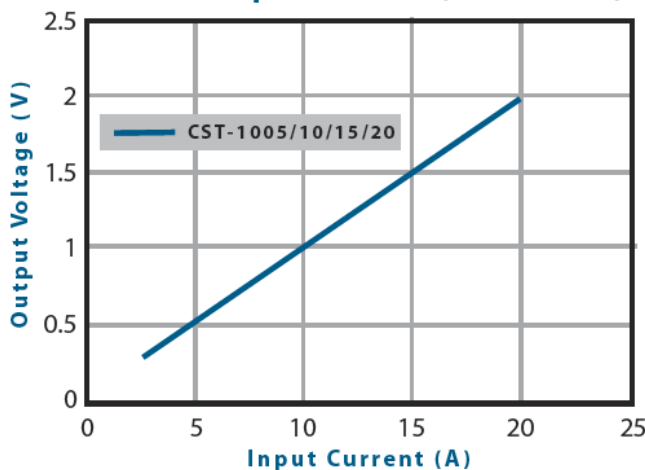

#### Technical Notes:

1. Pin3 for mechanical support only.
2. Pin diameter is 0.8±0.1 mm.
3. Pin length is 5±1mm.

#### Agency Files:

UL file E205349 – Component, Instrument Transformer (XODW2)



**RoHS Compliance:** As of manufacturing date February 2005, all standard products meet the requirements of 2011/65/EU, known as the RoHS initiative.

\*Upon printing, this document is considered “uncontrolled”. Please contact Triad Magnetics website for the most current version. For soldering and washing information please see <http://www.triadmagnetics.com/faq.html>

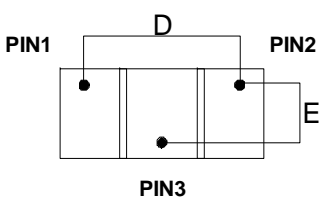
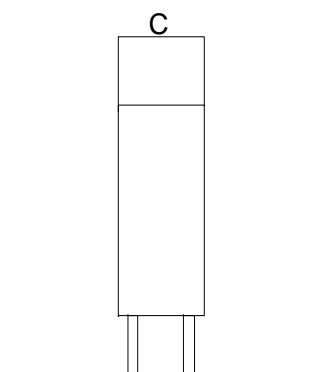
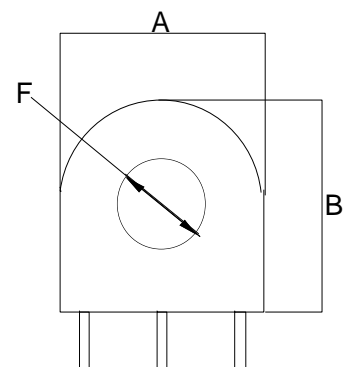
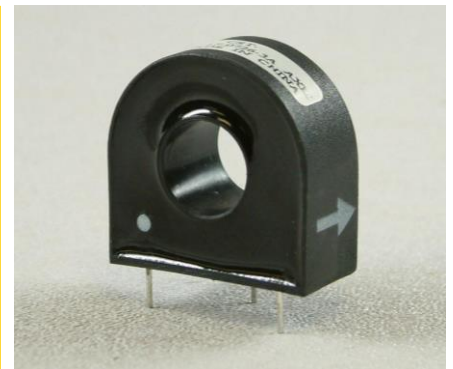

BOTTOM VIEW

