

SPECIFICATION CONTROL DRAWING

44A0711

TITLE WIRE, ELECTRIC, RADIATION-CROSSLINKED, POLYALKENE INSULATED, NORMAL WEIGHT, AIRFRAME, 600 VOLT

Date 5-25-05

Revision F

This specification sheet forms a part of the latest issue of Raychem Specification 44 and MIL-W-81044 as applicable.

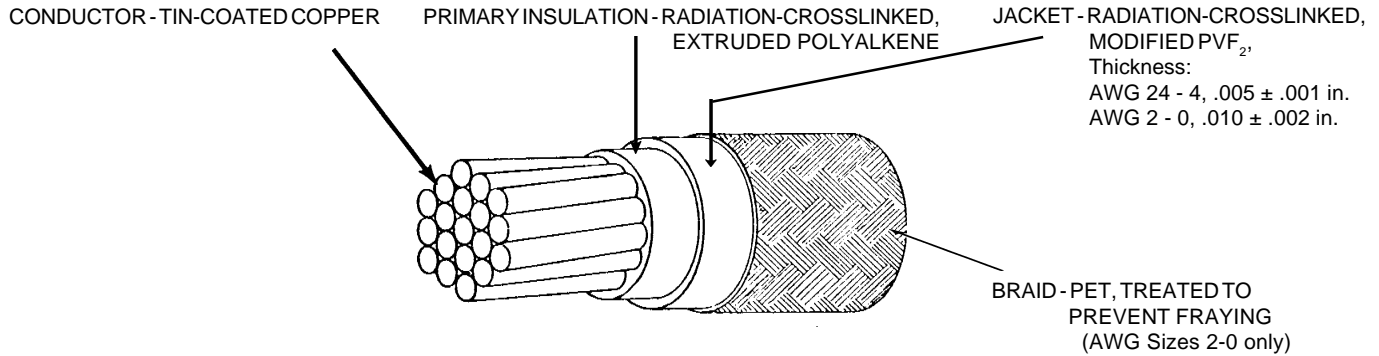

TABLE I. CONSTRUCTION DETAILS

| PART NUMBER 1/ | WIRE SIZE (AWG) | CONDUCTOR STRANDING (number x AWG) | DIAMETER OF STRANDED CONDUCTOR (in.) | | FINISHED WIRE | | |
|-------------------|--------------------|---------------------------------------|--------------------------------------|---------|--|----------------|-----------------------------|
| | | | MINIMUM | MAXIMUM | MAXIMUM RESISTANCE AT 20°C (ohms/1000ft) | DIAMETER (in.) | MAXIMUM WEIGHT (lbs/1000ft) |
| | | | | | | | |
| 44A0711-24-* | 24 | 19 x 36 | .023 | .026 | 26.2 | .057 ± .002 | 3.0 |
| 44A0711-22-* | 22 | 19 x 34 | .029 | .033 | 16.2 | .069 ± .003 | 4.3 |
| 44A0711-20-* | 20 | 19 x 32 | .037 | .041 | 9.88 | .078 ± .003 | 6.1 |
| 44A0711-18-* | 18 | 19 x 30 | .046 | .051 | 6.23 | .088 ± .003 | 8.7 |
| 44A0711-16-* | 16 | 19 x 29 | .052 | .058 | 4.81 | .097 ± .004 | 10.9 |
| 44A0711-14-* | 14 | 19 x 27 | .065 | .073 | 3.06 | .115 ± .004 | 16.2 |
| 44A0711-12-* | 12 | 37 x 28 | .084 | .090 | 2.02 | .131 ± .004 | 24.2 |
| 44A0711-10-* | 10 | 37 x 26 | .106 | .114 | 1.26 | .161 ± .005 | 36.5 |
| 44A0711- 8-* | 8 | 133 x 29 | .158 | .173 | .701 | .219 ± .006 | 65.0 |
| 44A0711- 6-* | 6 | 133 x 27 | .198 | .217 | .445 | .269 ± .007 | 103. |
| 44A0711- 4-* | 4 | 133 x 25 | .250 | .274 | .280 | .325 ± .008 | 158. |
| 44A0711- 2-* | 2 | 665 x 30 | .320 | .340 | .183 | .418 ± .013 | 252. |
| 44A0711- 1-* | 1 | 817 x 30 | .360 | .380 | .149 | .460 ± .015 | 305. |
| 44A0711- 0-* | 0 | 1045 x 30 | .405 | .425 | .116 | .508 ± .017 | 380. |

TABLE II. PERFORMANCE DETAILS

| PART NUMBER 1/ | BEND TESTING | | | | |
|-------------------|----------------------------------|-----------|--------|----------------------------------|-----------|
| | MANDREL DIAMETER (inch) (± 3%) | | | WEIGHT (lb) (± 3%) | |
| | LIFE CYCLE AND ACCELERATED AGING | COLD BEND | + WRAP | LIFE CYCLE AND ACCELERATED AGING | COLD BEND |
| 44A0711-24-* | .500 | 1.00 | .250 | 1.00 | 3.00 |
| 44A0711-22-* | .750 | 1.00 | .250 | 3.00 | 3.00 |
| 44A0711-20-* | .750 | 1.00 | .250 | 4.00 | 4.00 |
| 44A0711-18-* | 1.00 | 1.50 | .375 | 4.00 | 4.00 |
| 44A0711-16-* | 1.00 | 1.50 | .375 | 5.00 | 5.00 |
| 44A0711-14-* | 1.50 | 2.00 | .500 | 5.00 | 5.00 |
| 44A0711-12-* | 2.00 | 2.00 | .500 | 5.00 | 5.00 |
| 44A0711-10-* | 3.00 | 3.00 | .750 | 5.00 | 5.00 |
| 44A0711- 8-* | 3.00 | 4.00 | .750 | 6.00 | 6.00 |
| 44A0711- 6-* | 4.00 | 5.00 | 1.00 | 6.00 | 10.0 |
| 44A0711- 4-* | 5.00 | 6.00 | 1.25 | 6.00 | 10.0 |
| 44A0711- 2-* | 6.00 | 8.00 | 3.00 | 6.00 | 15.0 |
| 44A0711- 1-* | 8.00 | 10.0 | 4.00 | 7.00 | 15.0 |
| 44A0711- 0-* | 8.00 | 10.0 | 4.00 | 7.00 | 15.0 |

+ See Note on Page 2

Users should evaluate the suitability of this product for their application. Specifications are subject to change without notice. Tyco Electronics also reserves the right to make changes in materials or processing, which do not affect compliance with any specification, without notification to Buyer.

1/ COLORS AND COLOR CODE DESIGNATORS SHALL BE IN ACCORDANCE WITH MIL-STD-681. OTHER CODES AND SUFFIXES MAY BE ADDED TO THE PART NUMBER, AS NECESSARY, TO CAPTURE ANY ADDITIONAL REQUIREMENTS IMPOSED BY THE PURCHASE ORDER.



Raychem Wire & Cable
501 Oakside Avenue
Redwood City, CA 94063-3800
Phone: 1-800-227-8816
Fax: 1-650-361-6297

DIMENSIONS ARE IN INCHES, AND UNLESS OTHERWISE DESIGNATED ARE NOMINAL.

THIS SPECIFICATION SHEET TAKES PRECEDENCE OVER DOCUMENTS REFERENCED HEREIN. REFERENCED DOCUMENTS SHALL BE OF THE ISSUE IN EFFECT ON DATE OF INVITATION FOR BID.

WIRE RATINGS AND ADDITIONAL REQUIREMENTS

TEMPERATURE RATING: 150°C

Maximum continuous conductor temperature

VOLTAGE RATING: 600 volts (rms) at sea level

+ ACCELERATED AGING: 300 ± 2°C for 6 hours

Identification legibility, (AWG 24-4 only) 225 ± 2°C for 6 hours

BLOCKING: 150 ± 2°C for 24 hours

BRAID COLOR: Per MIL-STD-104, Class 2, except that light brown shall

be within munsell color limits (see Table III); nominal, 2.5 YR 3/6

FLAMMABILITY: 30 seconds (maximum); 3 in. (maximum); no flaming of facial tissue

HUMIDITY RESISTANCE: Insulation Resistance, 5000 Megohms for 1000 ft. (minimum)

IDENTIFICATION, STRIPING, OR BAND DURABILITY (AWG 24-4 only):

125 cycles (250 strokes) (minimum), 500 g weight

IMMERSION: Diameter increase 5% (maximum); no cracking, no dielectric breakdown

INSULATION ELONGATION AND TENSILE STRENGTH:

Primary Insulation,

Tensile Strength, 2500 lbf/in² (minimum), AWG 24-12

2000 lbf/in² (minimum), AWG 10-0

Elongation, 150% (minimum)

INSULATION FLAWS:

Primary Insulation,

SparkTest, 3.0 kV (rms) at 60 Hz

4.2 kV (rms) at 3 kHz

Impulse DielectricTest, 6.0 kV (peak)

Finished Wire;

SparkTest, 5.7 kV (rms) at 3 kHz

Impulse DielectricTest, 8.0 kV (peak)

INSULATION RESISTANCE: 5000 Megohms for 1000 ft. (minimum)

JACKET COLOR (AWG 2-0 only): White

+ LIFE CYCLE: 200 ± 2°C for 168 hours

LOW TEMPERATURE-COLD BEND: -65 ± 2°C for 4 hours

+ SHRINKAGE: 300 ± 2°C, 0.125 in. (maximum) in 12 in., AWG 24-12

300 ± 2°C, 0.250 in. (maximum) in 12 in., AWG 10-0

SMOKE: 200 ± 2°C. No visible smoke.

SOLDERABILITY: Per MIL-STD-202, Method 208, except without steam aging, Type RMA Flux

+ SURFACE RESISTANCE: 500 megohms-in. (minimum), both readings

THERMAL SHOCK: 150 ± 2°C, 0.060 in. (maximum), primary insulation and jacket only.

VOLTAGE WITHSTAND (POST ENVIRONMENTAL): 2500 volts (rms), 60 Hz, 5 minutes

WICKING: 2.25 in. (maximum) between primary insulation and jacket.

PART NUMBER: The "*" in the part numbers on page 1 shall be replaced by

color code designators except that Lt. brown shall be designated as -1L

For AWG 2-0, only the braid color shall be designated.

1/ Example:

AWG 20, white: 44A0711-20-9

AWG 20, white with black stripe: 44A0711-20-90

AWG 2, white jacket, Lt. brown braid: 44A0711-2-1L

1/ See footer section on page 1

+ NOTE: For AWG 2-0, these tests are conducted prior to application of the braid.

| TABLE III. MUNSELL COLOR LIMITS | |
|------------------------------------|-----------|
| HUE | 5R - 5YR |
| VALUE | 3.0 - 5.0 |
| CHROMA | 4.0 - 6.0 |

Mouser Electronics

Authorized Distributor

Click to View Pricing, Inventory, Delivery & Lifecycle Information:

[TE Connectivity:](#)

[81044/6-0-9](#)