

PART NUMBER	REV	FIRST USED	POWER UNIT	FEED TYPE	DESCRIPTION
1855058-1	A	122500-1	LEADMAKER	POST FEED	CUTS CARRIER
1855058-2	A	565435-5	BENCH MODEL K	PRE FEED	CUTS CARRIER
1855058-3	A	354500-1	BENCH MODEL G	PRE FEED	CUTS CARRIER
1855058-6	A	122500-1	LEADMAKER	POST FEED	CONTINUOUS CARRIER
7-1855058-7	A	-	-	-	SPARE PARTS

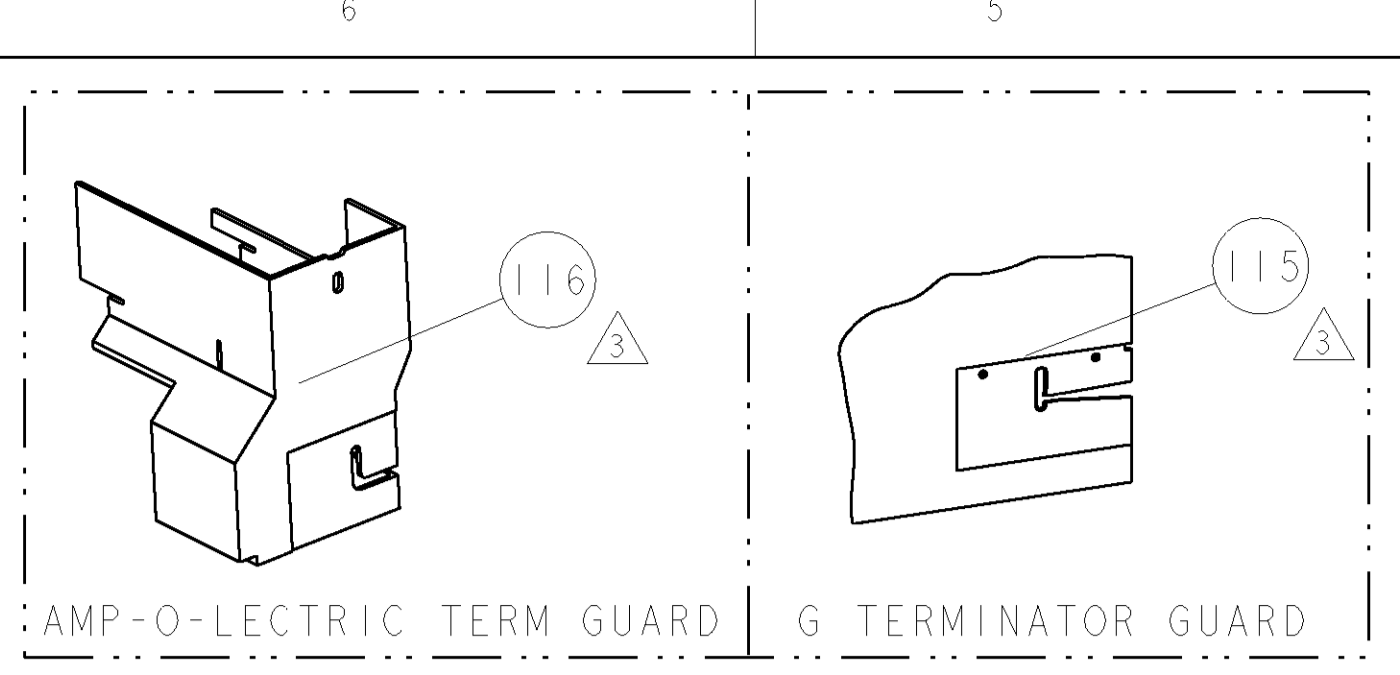

TERMINAL NAME: SHUR-PLUG				
AMP PN		AMP TERMINAL - AMP CRIMP SPECS		
42865	-			
63156	-	REF SETTING	CRIMP HEIGHT	WIRE SIZE
-	-	C1	.115±.002[2.92±0.05mm]	10 AWG $\Delta$ $\Delta$
-	-	B5	.095±.002[2.41±0.05mm]	12 AWG
-	-	D3	.083±.002[2.11±0.05mm]	14 AWG
-	-			
-	-	CRIMP	SIZE	TYPE RANGE
-	-	WIRE	.130 [3.30mm]	F 14-10 AWG
-	-	INSUL	-	-
WIRE STRIP LENGTH	TERM APPL SPEC	FEED	APPL INSTRUCTIONS	SET UP GAGE
.219 - .249	114-2017	.626	408-8040	458637-1

LOC	DIST	P	LTR	DESCRIPTION	DATE	DWN	APPR
A	66			RELEASED	20APR2006	RK	TE

- $\Delta$  RECOMMENDED SPARE PARTS
- $\Delta$  GREASE LIGHTLY
- $\Delta$  GUARD MUST BE IN PLACE WHEN OPERATING APPLICATOR IN A BENCH MACHINE
- $\Delta$  MAX CMA 9600.
- $\Delta$  GRIND AT ASSEMBLY.
- $\Delta$  REMOVE ITEM 39 WHEN RUNNING 10 AWG WIRE.

-	2	2	2	2	-	1-21000-3	SCR, SKT HD CAP 4-40 X .250	123
-	2	2	2	2	-	5-21006-6	SCR, SET, CUP POINT 10-32 X .750	122
-	1	1	1	1	-	693855-1	FRONT STRIP GUIDE	121
$\Delta$	-	-	REF	-	-	455749-1	GUARD WINDOW	116
$\Delta$	-	-	REF	-	-	679532-1	INSERT, GUARD	115
-	1	1	1	1	-	2-21002-6	SCR, BTN SKT HD CAP 10-32 X .375	114
-	-	-	-	-	-	1-465184-0	LUBRICATOR ASSY	113
-	1	1	1	1	-	1-21002-7	SCR, BTN SKT HD CAP 6-32 X .375	91
-	1	1	1	1	-	691668-1	GUARD, REAR CHIP	90
-	1	1	1	1	-	318563-1	GUARD, FRONT CHIP	89
-	1	1	1	1	-	455888-1	SPACER, CRIMPER	82
-	1	1	1	1	-	2-240641-6	SPACER	81
-	1	1	1	1	-	4088040	SF APPL INST 408-8040	72
-	1	1	1	1	-	217238-1	GENERAL INSTRUCTION PKG	71
-	2	2	2	2	-	21024-2	WASHER, SPRG LOCK, REG NO 4	68
-	1	1	1	1	-	461264-5	PLATE, IDENTIFICATION	67
-	2	2	2	2	-	21017-2	SCREW, DRIVE	66
-	1	1	1	1	-	21009-2	SCR, SET, SELF LOCKING 1/4-20 X .250	63
-	1	1	1	1	-	22733-8	SCR, BHSC, SELF-LOCKING, 8-32 X .375	60
-	1	1	1	1	-	2-22603-0	SCR, HEX HD CAP 8-32 X .312	59
-	1	1	1	1	-	458537-2	PAWL, FEED	56
$\Delta$	4	4	4	4	-	2-21002-2	SCR, BTN SKT HD CAP 8-32 X .500	54
-	2	2	2	2	-	3-21000-1	SCR, SKT HD CAP 8-32 X 1.000	53
-	-	1	-	-	-	690602-6	CAM, PRE FEED, 1 5/8	49
-	-	-	1	-	-	690602-5	CAM, PRE FEED, 1 1/8	48
-	1	1	1	1	-	690501-4	CAM, POST FEED, 1 5/8	47
-	1	1	1	1	-	459456-1	APPL. BASIC SUB ASSY (SIDE WISE MOCA)	46
-	1	1	1	1	-	690191-1	PLUG, NYLON	45
-	1	1	1	1	-	1-455673-4	RAM, SIDE FEED	44
$\Delta$	1	1	1	1	-	7-21002-9	SCR, SKT HD CAP 5/16-24 X 1.000	41
$\Delta$	1	1	1	1	-	469367-8	SHIM	39
-	1	1	1	1	-	469367-8	SHIM	38
-	1	1	1	1	-	879103-4	FINE ADJUST HEAD SUBASSY	37
-	2	2	2	2	-	2-21002-4	SCR, BTN SKT HD CAP 8-32 X .750	33
-	1	1	1	1	-	21024-5	WASHER, SPRG LOCK, REG NO 10	32
-	1	1	1	1	-	3-21000-4	SCR, SKT HD CAP 10-32 X .375	31
-	1	1	1	1	-	1320908-8	SPACER, STRIP GUIDE	30
-	1	1	1	1	-	1633091-6	ASSEMBLY, STRIP GUIDE	29
-	2	2	2	2	-	1-22284-0	SPRING, COMPRESSION	27
-	1	1	1	1	-	356835-1	LEVER, DRAG RELEASE	26
-	1	1	1	1	-	240792-5	DRAG, TERMINAL	25
-	1	1	1	1	-	1320928-1	PLATE, STRIP GUIDE	24
-	1	1	1	1	-	21989-8	SCR, SKT HD SHLDR 3/16 DIA X .250	23
-	1	1	1	1	-	690472-1	STRIPPER	22
-	1	1	1	1	-	2-21000-7	SCR, SKT HD CAP 8-32 X .500	21
-	4	4	4	4	-	21024-4	WASHER, SPRG LOCK, REG NO 8	20
-	-	1	1	1	-	691353-1	STRIPPER	19
-	1	1	1	1	-	690461-1	STOP, SHEAR	18
-	1	1	1	1	-	679625-2	SHEAR HOLDER, FRONT (NO CUT)	17
-	2	2	2	2	-	1-21000-9	SCR, SKT HD CAP 6-32 X .375	16
$\Delta$	1	1	1	1	-	690691-2	PLATE, REAR SHEAR	15
$\Delta$	1	1	1	1	-	690462-1	SHEAR HOLDER, REAR	14
$\Delta$	1	1	1	1	-	690463-1	FLOATING SHEAR, REAR	13
$\Delta$	2	2	2	2	-	3-22280-3	SPRING, COMPRESSION	12
$\Delta$	1	1	1	1	-	690461-7	STOP, SHEAR	11
$\Delta$	-	1	1	1	-	1-690459-0	SHEAR HOLDER, FRONT	10
$\Delta$	1	1	1	1	-	454276-5	FLOATING SHEAR, FRONT	9
$\Delta$	1	1	1	1	-	690512-5	ANVIL, COMBINATION	8
-	1	1	1	1	-	690468-1	DEPRESSOR SHEAR, REAR	6
-	1	1	1	1	-	1-455889-6	DEPRESSOR, SHEAR	5
-	1	1	1	1	-	455888-6	SPACER, CRIMPER	2
$\Delta$	1	1	1	1	-	456410-7	CRIMPER, WIRE PREMIUM	1

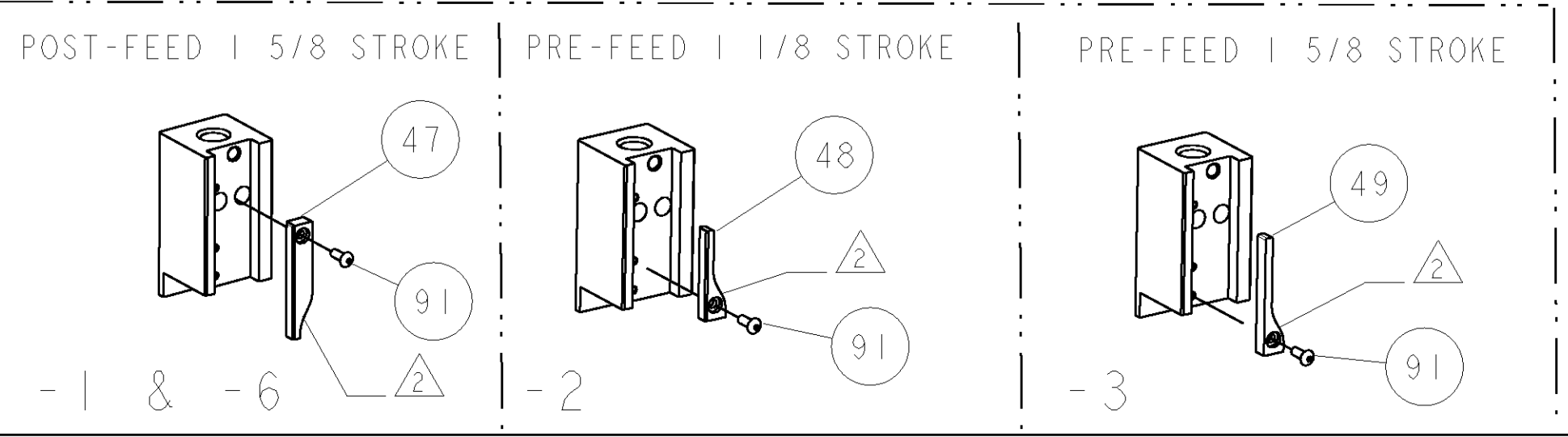
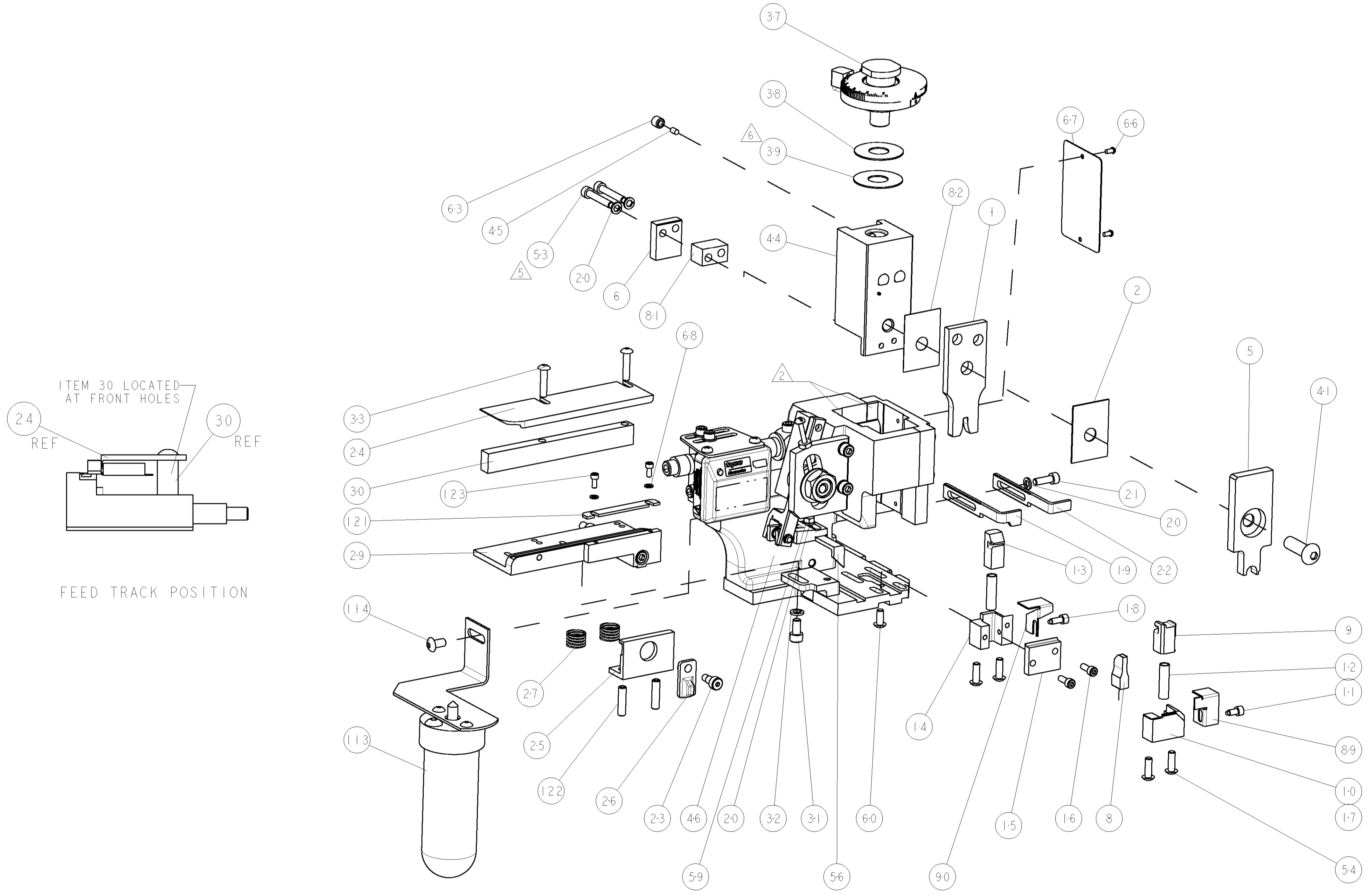

DIMENSIONS: INCHES		TOLERANCES UNLESS OTHERWISE SPECIFIED:		DWG: KNEPPER		Z2MAR2006		tyco Tyco Electronics Harrisburg, PA 17105-3608	
0 PLC	±	1 PLC	±0.1	2 PLC	±0.01	3 PLC	±0.001	4 PLC	±0.0001
MATERIAL		FINISH		APPR: BENCHOFF		NAME		PRODUCT SPEC	
				APPLICATION SPEC		SIZE: CAGE CODE: DRAWING NO		RESTRICTED TO	
				WEIGHT		A1 00779		SCALE: 3:5 SHEET 1 OF 1 REV A	
CUSTOMER DRAWING									

CUSTOMER VIEWABLE ASSEMBLY

# Mouser Electronics

Authorized Distributor

Click to View Pricing, Inventory, Delivery & Lifecycle Information:

[TE Connectivity:](#)

[1855058-2](#)