

REV. NO.	REVISIONS		
	DATE	BY	CHK
C2	REvised	ECO-11-005140	02APR2011 RK HMR
C3	REvised	ECO-11-013395	29AUG2011 YN YF
C4	REvised	ECR-13-006139	11APR2013 TS HY
C5	REvised	ECR-14-005369	10APR2014 KT RK

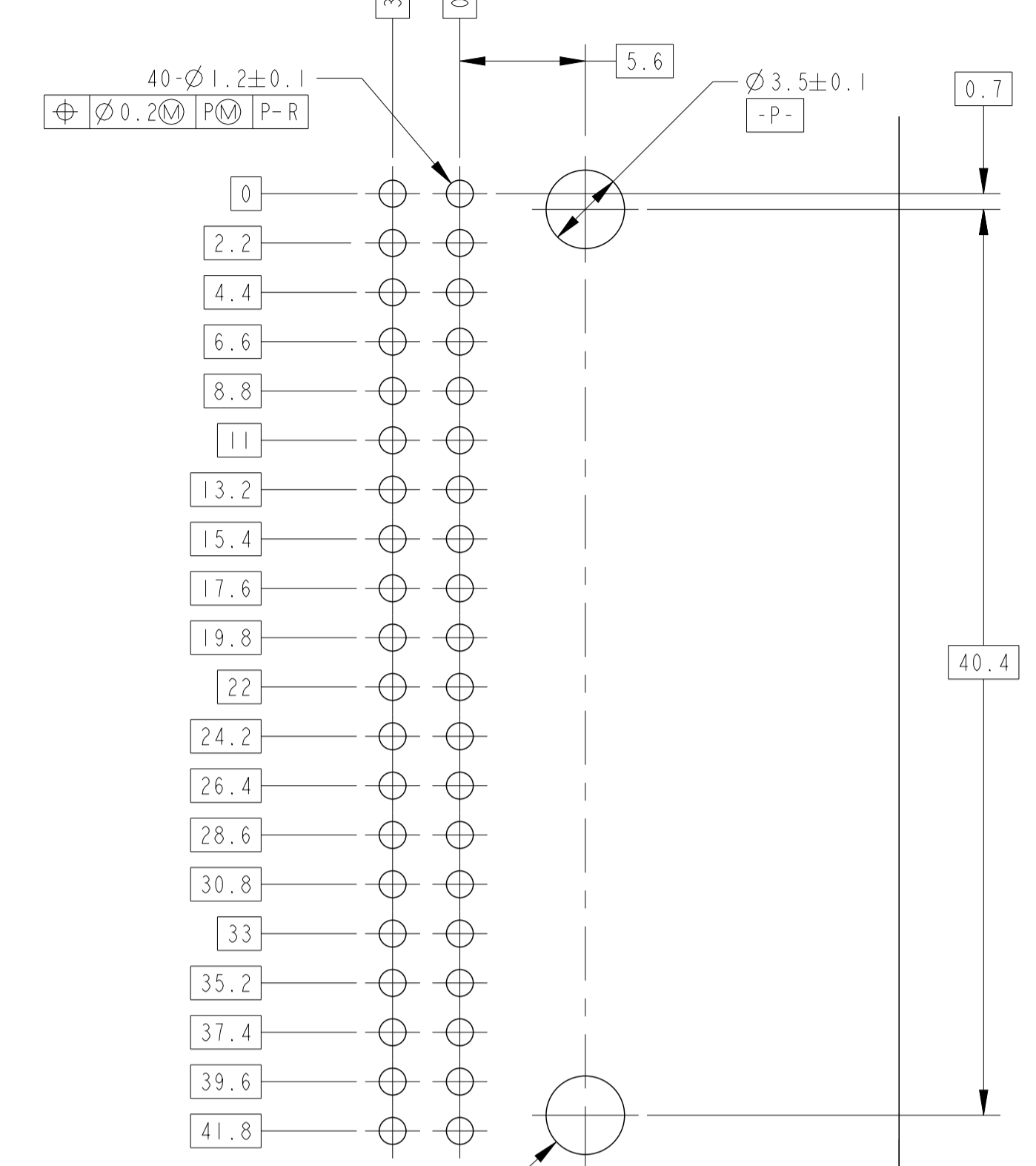

DIMENSION FOR PCB
 プリント基板取付寸法

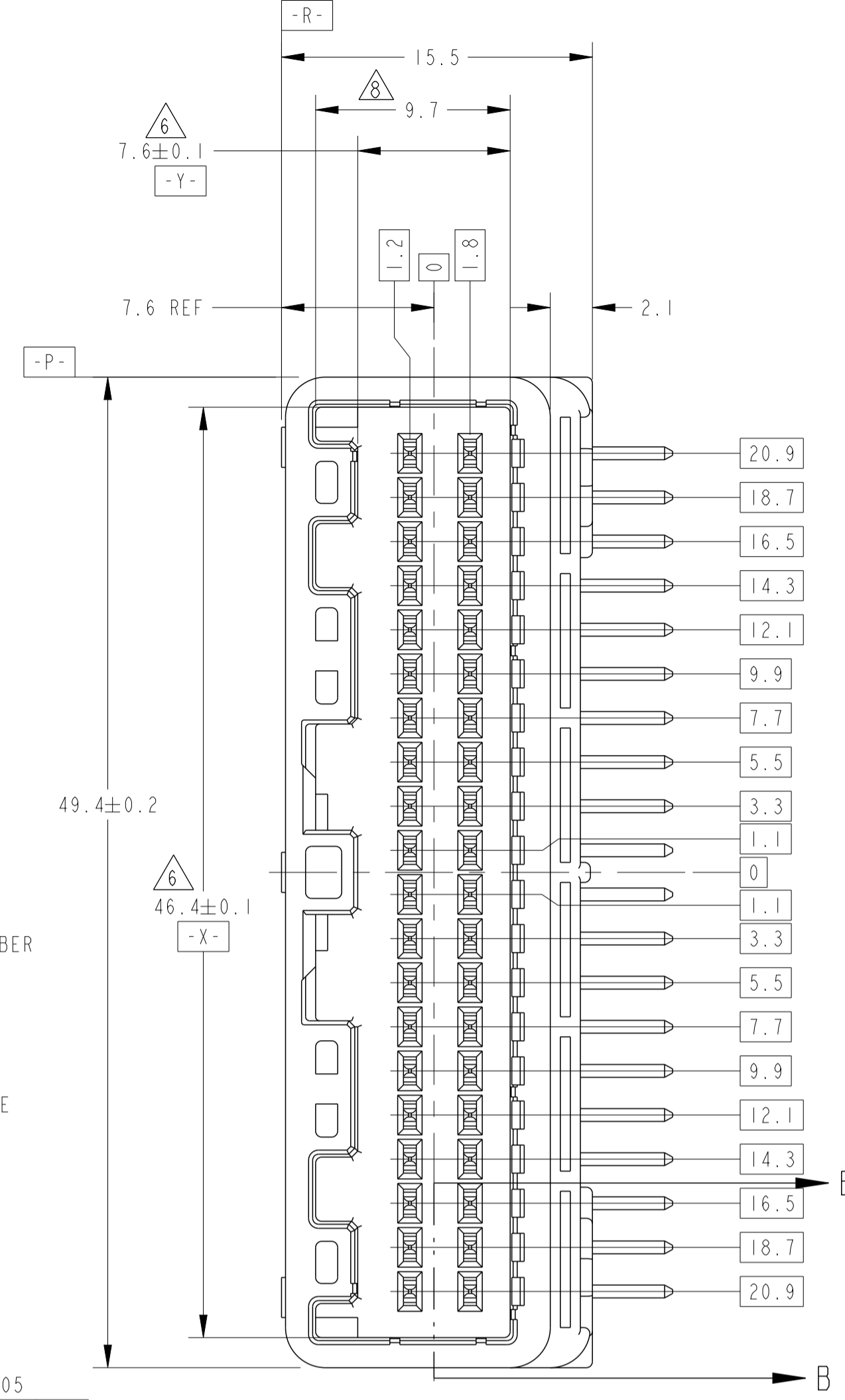
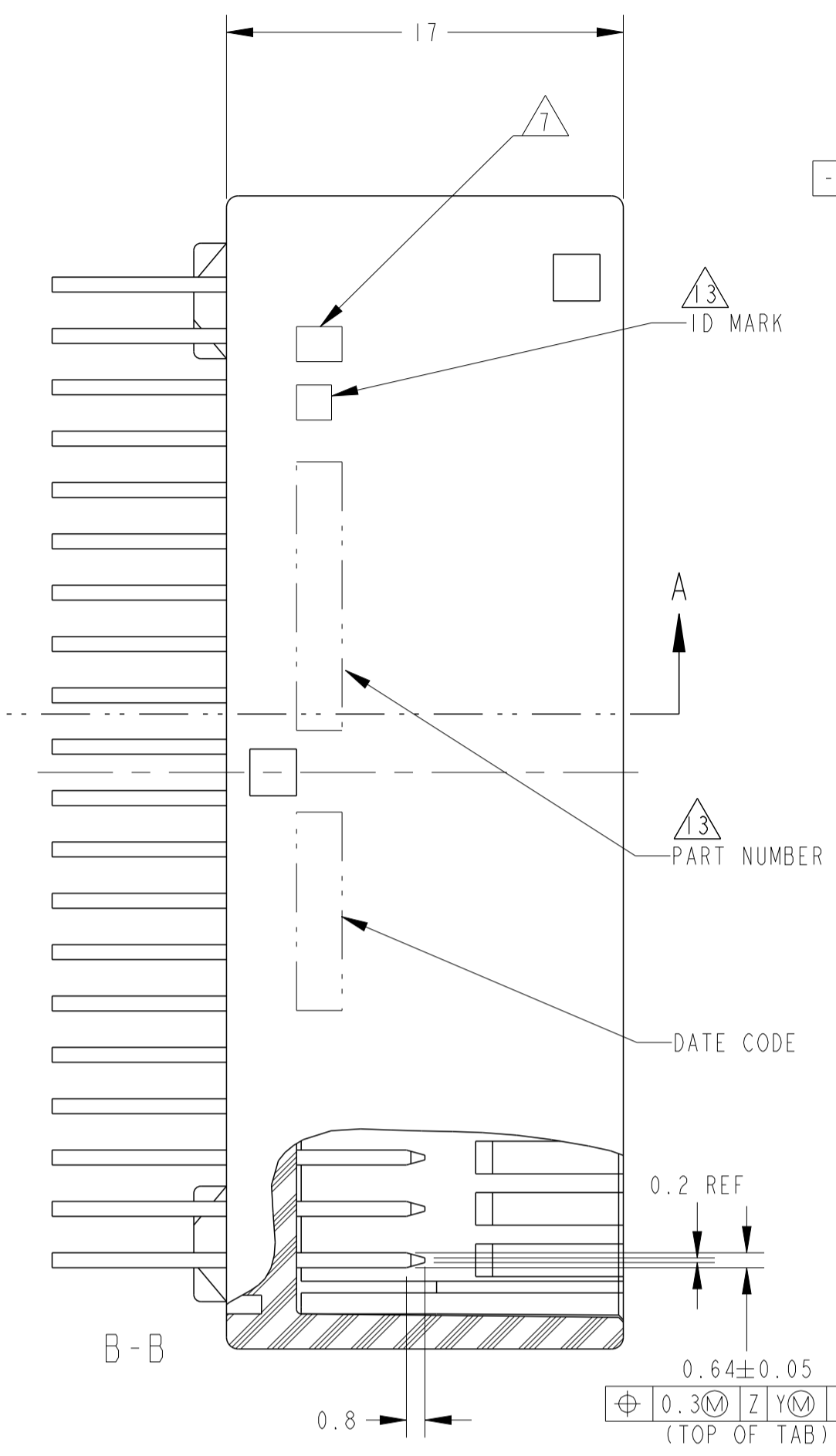
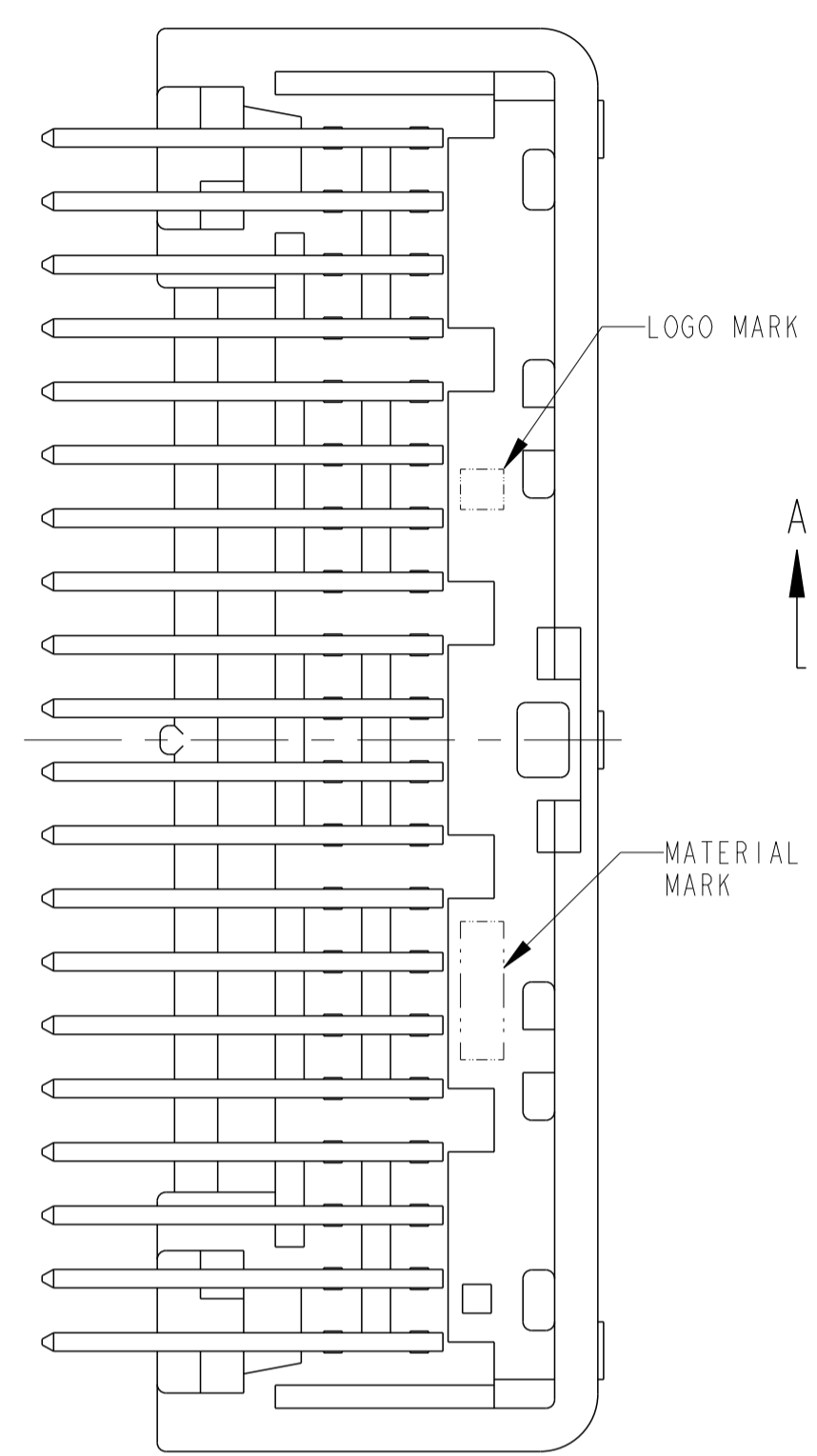
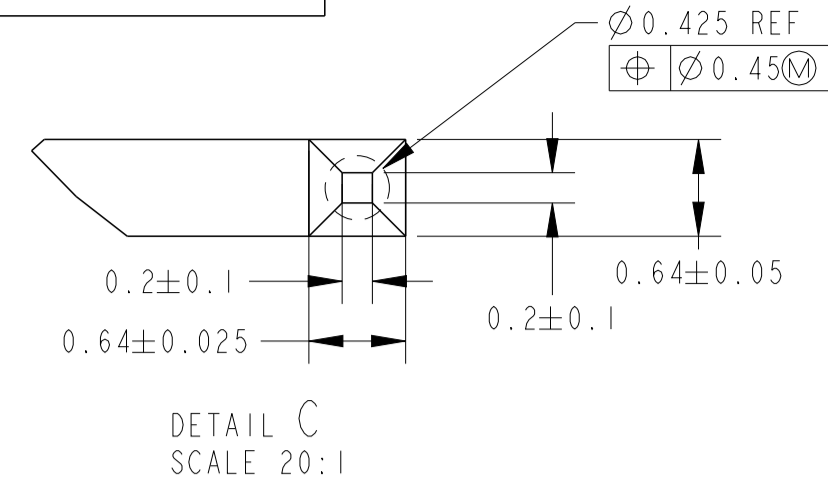
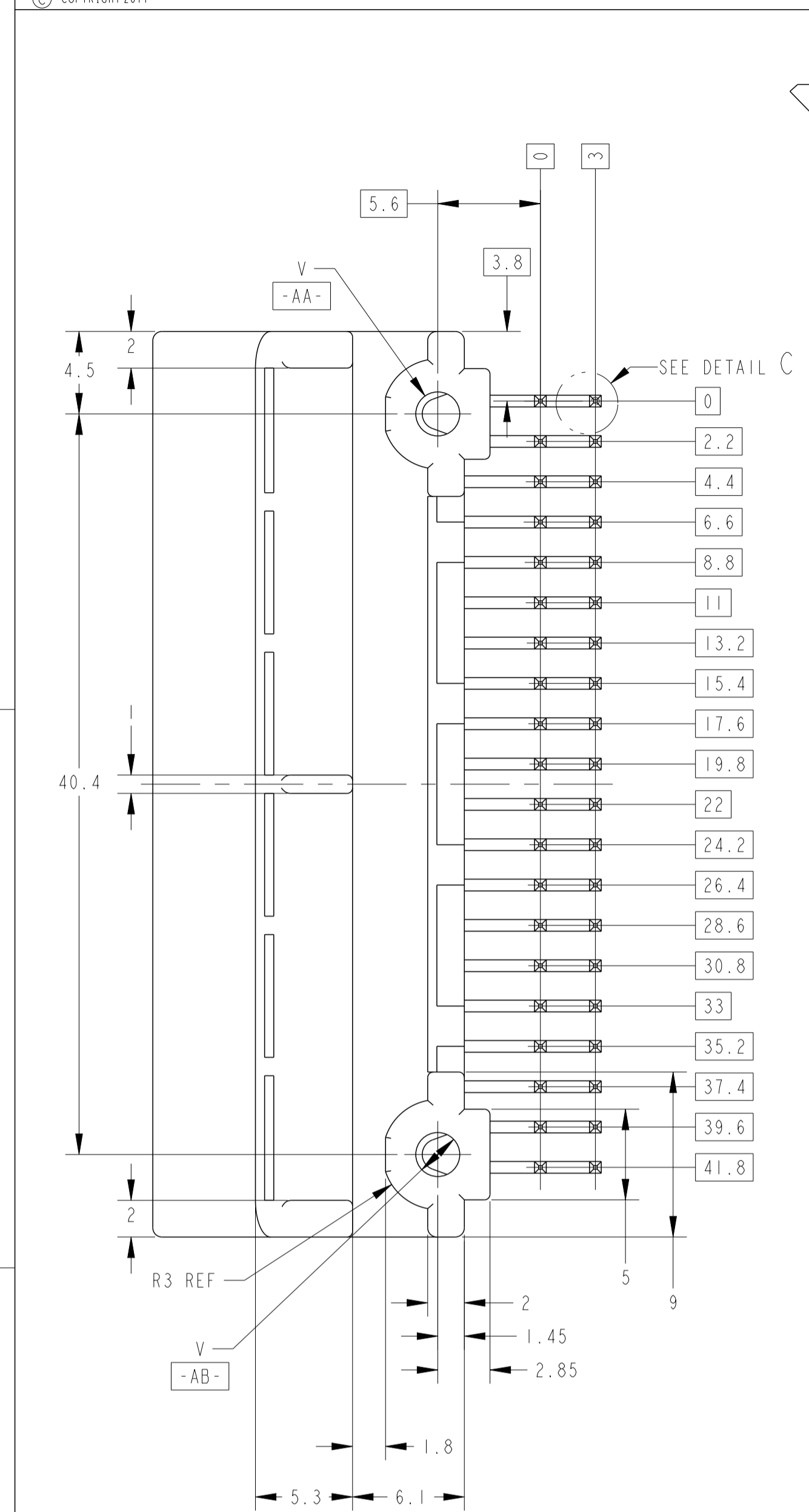
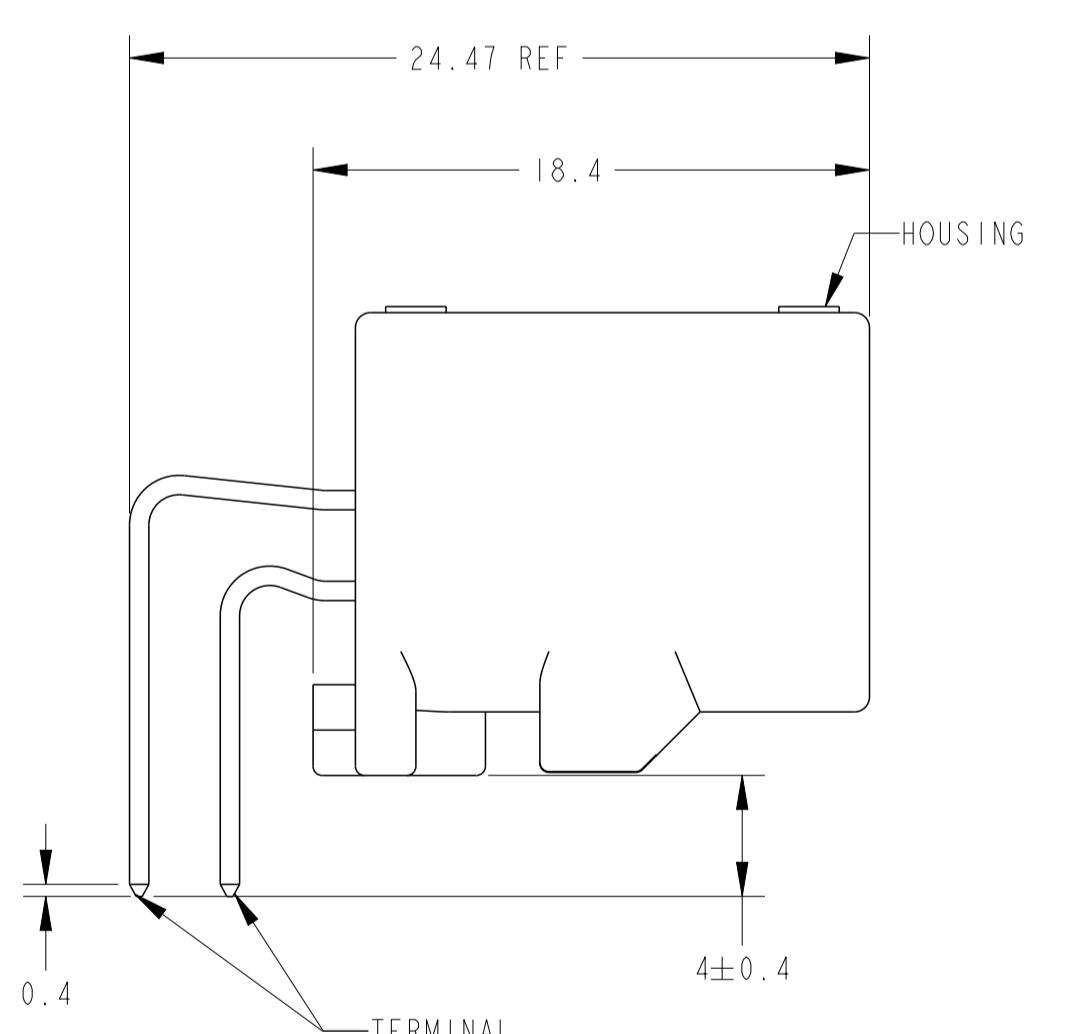
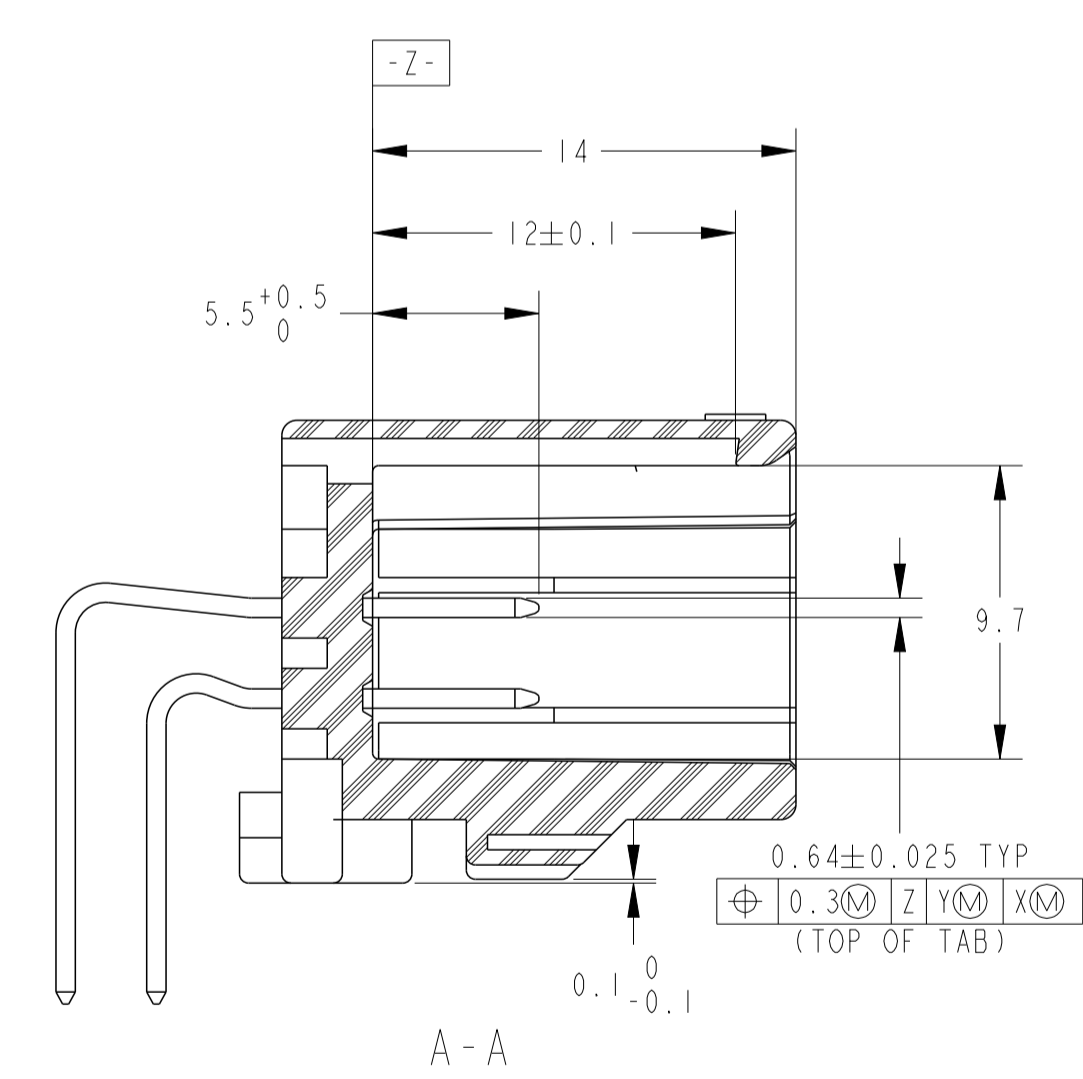

1. PLUG HOUSING TO BE MATED; SEE TABLE-1.
 2. DETAIL OF TERMINALS TO BE MATED; SEE TABLE-2.
 3. RECOMMENDED SCREW: PAN-HEADED, TYPE 2 TAPPING SCREW, NOMINAL DIAMETER 3mm LENGTH; SEE TABLE-3 (JIS B1115, B1122). FASTENING TORQUE FOR SCREW (FOR REFERENCE): 0.392N·m MAX.
 4. FASTENING TORQUE FOR SCREW (FOR REFERENCE): 0.392N·m MAX.
 5. AS FOR THE HANDLING OF THIS PRODUCT, FOLLOW THE INSTRUCTION SHEET No. 411-5928, 411-78080.
- △ MEASURED AT 6mm FROM -Z-
 - △ IDENTIFICATION MARK OF THE CONTACT FINISH; SEE TABLE.
 - △ MEASURED AT 2mm FROM -Z-
 - △ PRELIMINARY - NOT RELEASED FOR PRODUCTION.
 - △ CIRCUIT NUMBER: SEE FIG.1
 - △ NO IDENTIFICATION MARK OF CONTACT FINISH AND ID MARK
 - △ GOLD PLATING POSITION: SEE SHEET 20F3.
 - △ ID MARK, PART NUMBER INDICATED.
1. 嵌合相手ハウジング型番: TABLE-1 参照
 2. 嵌合相手端子構成: TABLE-2 参照
 3. 推奨取付ねじ: JIS B1115, B1122タッピングねじ, ねじ径3, 長さ: TABLE-3参照
 4. ねじ締付トルク(参考値): 0.392N·m MAX
 5. 本品の取扱いについては、取扱説明書 No.: 411-5928, 411-78080に準うこと
- △ -Z- より6mmの位置で測定。
 - △ コンタクト仕上識別用マーク; SEE TABLE
 - △ -Z- より2mmの位置で測定。
 - △ 試作の熱処理をされていない
 - △ 回路番号: FIG.1参照
 - △ コンタクト仕上識別用マーク及びIDマークの刻印は無し
 - △ 金のめっき位置: SHEET 20F3 参照
 - △ ID MARK, PART NUMBERを表示。

TABLE-3

プリント基板板厚 (mm)	1.2	1.6
THICKNESS OF PCB (mm)		
固定用ねじ着下長さ (mm)	5	6
NOMINAL LENGTH OF SCREW (mm)		

TABLE-1

POS 極数	TYPE	FEMALE HSG メスハウジング	
		PART NO	適用電線 (メス)
40	CRIMP	1318389(1), 1674312(111)	
40	IDC	1318691 1318695	

TABLE-2

SIGNAL	POS 極数	APPLICABLE WIRE RANGE (FEMALE)
		適用電線 (メス)
025	40	CAVS/CAVUS 0.22~0.5mm ² AVSS/AVSSH 0.3~0.5mm ²

THIS DRAWING IS A CONTROLLED DOCUMENT.

OWNER: N. YASUDA, OSMAROO
 CHK: N. SAI, TOMAROO
 APVD: N. SAI, TOMAROO

PRODUCT SPEC: 108-5660
 APPLICATION SPEC: 108-5668, 108-5931

WEIGHT: SEE TABLE
 SIZE: A1
 CAGE CODE: 00779
 DRAWING NO: 1318384

Customer Drawing
 SHEET 1 OF 3
 REV. C5

STE TE Connectivity
 025 SERIES 40P (PCB H-TYPE)
 CAP HSG ASSY

THIS DRAWING IS UNPUBLISHED. RELEASED FOR PUBLICATION 2011
 © COPYRIGHT 2011 ALL RIGHTS RESERVED.

LOC	DIST	REVISIONS					
J	-	P	LTR	DESCRIPTION	DATE	DWN	APVD
		-		SEE SHEET 1			

MARKING	WEIGHT(g)	V	GOLD PLATING POSITION	PACKING STYLE	CONTACT FINISH	HOUSING	PART NUMBER	
マ-キ-ン-グ	重-量		金-め-り-の-位-置	梱-包-形-態	接-触-部-の-仕-上	ハウ-ジ-ン-グ	製-品-型-番	
7	9.6	∅2.4	—//—	PAPER BOX ダンボール箱	PLASTIC TUBE プラスチックチューブ	PRE-TIN x 40	PBT GF15 BLACK 黒色 2-1318384-6	
16	9.6	∅2.4	6, 7, 13, 14, 20 26, 27, 33, 34, 40	PAPER BOX ダンボール箱	PLASTIC TUBE プラスチックチューブ	SELECTIVE-TIN (MATTE) SELECTIVE-TIN (BRIGHT) x 30 SELECTIVE GOLD x 10	PBT GF15 NATURAL 自然色 2-1318384-4	
15	8.4	∅2.63	9-11, 13, 14, 16 29-31, 33, 34, 36-40	PLASTIC BOX 通い箱	PLASTIC TUBE プラスチックチューブ	SELECTIVE-TIN (MATTE) SELECTIVE-TIN (BRIGHT) x 24 SELECTIVE GOLD x 16	SPS GF17 BLACK 黒色 2-1318384-3	
13	8.4	∅2.63	9-11, 13, 14, 16 29-31, 33, 34, 36	PLASTIC BOX 通い箱	PLASTIC TUBE プラスチックチューブ	SELECTIVE-TIN (MATTE) SELECTIVE-TIN (BRIGHT) x 28 SELECTIVE GOLD x 12	SPS GF17 NATURAL 自然色 2-1318384-0	
60	9.6	∅2.4	1~40	PAPER BOX ダンボール箱	PLASTIC TUBE プラスチックチューブ	SELECTIVE-TIN (MATTE) SELECTIVE GOLD x 40	PBT GF15 NATURAL 自然色 6318384-5	
9	9.6	∅2.4	—//—	PAPER BOX ダンボール箱	PLASTIC TUBE プラスチックチューブ	SELECTIVE-TIN (MATTE) SELECTIVE-TIN x 40 (BRIGHT)	PBT GF15 NATURAL 自然色 1-1318384-9	
12	9.6	∅2.4	8-13, 28-33	PAPER BOX ダンボール箱	PLASTIC TUBE プラスチックチューブ	SELECTIVE-TIN (MATTE) SELECTIVE-TIN (BRIGHT) x 28 SELECTIVE GOLD x 12	PBT GF15 NATURAL 自然色 1-1318384-8	
11	8.4	∅2.63	6-8, 10, 11, 25 27, 28, 30, 31	PLASTIC BOX 通い箱	PLASTIC TUBE プラスチックチューブ	SELECTIVE-TIN (MATTE) SELECTIVE-TIN (BRIGHT) x 30 SELECTIVE GOLD x 10	SPS GF17 NATURAL 自然色 1-1318384-7	
10	9.6	∅2.4	6-8, 10, 11, 25 27, 28, 30, 31	PLASTIC BOX 通い箱	PLASTIC TUBE プラスチックチューブ	SELECTIVE-TIN (MATTE) SELECTIVE-TIN (BRIGHT) x 30 SELECTIVE GOLD x 10	PBT GF15 NATURAL 自然色 1-1318384-6	
10	9.6	∅2.4	6-8, 10, 11, 25 27, 28, 30, 31	PAPER BOX ダンボール箱	PLASTIC TUBE プラスチックチューブ	SELECTIVE-TIN (MATTE) SELECTIVE-TIN (BRIGHT) x 30 SELECTIVE GOLD x 10	PBT GF15 NATURAL 自然色 1-1318384-5	
9	9.6	∅2.4	—//—	PAPER BOX ダンボール箱	PLASTIC TUBE プラスチックチューブ	SELECTIVE-TIN (MATTE) SELECTIVE-TIN x 40 (BRIGHT)	PBT GF15 BLACK 黒色 1-1318384-4	
8	8.4	∅2.63	—//—	PAPER BOX ダンボール箱	PLASTIC TUBE プラスチックチューブ	SELECTIVE-TIN (MATTE) SELECTIVE-TIN x 40 (BRIGHT)	SPS GF17 NATURAL 自然色 1-1318384-3	
8	8.4	∅2.63	—//—	PLASTIC BOX 通い箱	PLASTIC TUBE プラスチックチューブ	SELECTIVE-TIN (MATTE) SELECTIVE-TIN x 40 (BRIGHT)	SPS GF17 NATURAL 自然色 1-1318384-2	
OBSOLETE	—6—	∅2.4	//	PAPER BOX ダンボール箱	PLASTIC TUBE プラスチックチューブ	SELECTIVE-TIN PRE-TIN x 40	PBT GF15 NATURAL 自然色 1-1612446-0	
	7	9.6	∅2.4	PLASTIC BOX 通い箱	PLASTIC TUBE プラスチックチューブ	PRE-TIN x 40	PBT GF15 BLACK 黒色 1-1318384-0	
OBSOLETE	6	9.6	∅2.4	PLASTIC BOX 通い箱	PLASTIC TUBE プラスチックチューブ	SELECTIVE-TIN PRE-TIN x 40	PBT GF15 NATURAL 自然色 1318384-9	
OBSOLETE	—5—	9.6	∅2.4	8-13, 28-33	PAPER BOX ダンボール箱	PLASTIC TUBE プラスチックチューブ	SELECTIVE-TIN PRE-TIN x 28 SELECTIVE GOLD x 12	PBT GF15 NATURAL 自然色 1318384-8
	//	9.6	∅2.4	1~40	PAPER BOX ダンボール箱	PLASTIC TUBE プラスチックチューブ	TIN LEAD SELECTIVE GOLD x 40	PBT GF15 NATURAL 自然色 1318384-5
	4	9.6	∅2.4	6-8, 10, 11, 25 27, 28, 30, 31	PLASTIC BOX 通い箱	PLASTIC TUBE プラスチックチューブ	SELECTIVE-TIN PRE-TIN x 30 SELECTIVE GOLD x 10	PBT GF15 NATURAL 自然色 1318384-7
OBSOLETE	—4—	9.6	∅2.4	6-8, 10, 11, 25 27, 28, 30, 31	PAPER BOX ダンボール箱	PLASTIC TUBE プラスチックチューブ	SELECTIVE-TIN PRE-TIN x 30 SELECTIVE GOLD x 10	PBT GF15 NATURAL 自然色 1318384-6
	3	9.6	∅2.4	—//—	PAPER BOX ダンボール箱	PLASTIC TUBE プラスチックチューブ	POST-TIN x 40	PBT GF15 NATURAL 自然色 1318384-4
	//	9.6	∅2.4	—//—	—//—	—//—	—//—	1318384-3
	1	9.6	∅2.4	—//—	PAPER BOX ダンボール箱	PLASTIC TUBE プラスチックチューブ	PRE-TIN x 40	PBT GF15 NATURAL 自然色 1318384-2
	1	9.6	∅2.4	—//—	PLASTIC BOX 通い箱	PLASTIC TUBE プラスチックチューブ	PRE-TIN x 40	PBT GF15 NATURAL 自然色 1318384-1

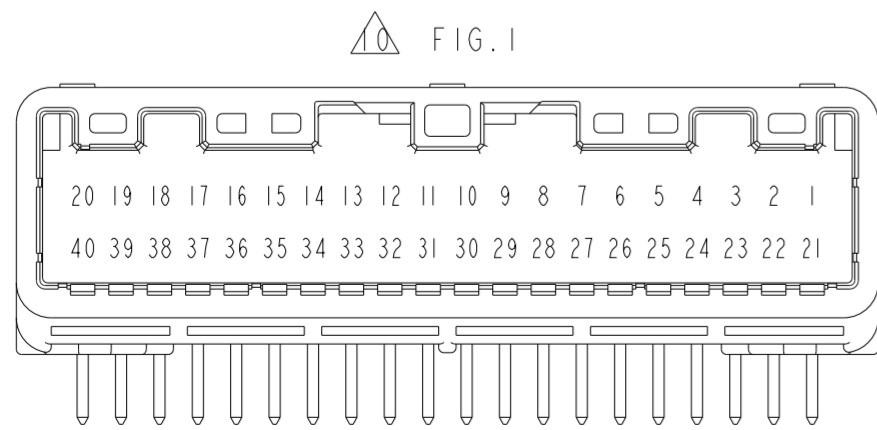

THIS DRAWING IS A CONTROLLED DOCUMENT.

DWN	N. YASUDA	08MAR00
CHK	N. SAI	10MAR00
APVD	N. SAI	10MAR00

PRODUCT SPEC: SEE SHEET 1 OF 3
 APPLICATION SPEC: SEE SHEET 1 OF 3
 WEIGHT: SEE SHEET 1 OF 3

MATERIAL: SEE SHEET 1 OF 3
 FINISH: SEE SHEET 1 OF 3

NAME: 025 SERIES 40P (PCB H-TYPE) CAP HSG ASSY
 SIZE: A2
 CAGE CODE: 00779
 DRAWING NO: C-1318384
 RESTRICTED TO: C5

SCALE: 4:1
 SHEET: 2 OF 3
 REV: C5

THIS DRAWING IS UNPUBLISHED.

RELEASED FOR PUBLICATION

2011

LOC

DIST

REVISIONS

© COPYRIGHT 2011

ALL RIGHTS RESERVED.

J

P	LTR	DESCRIPTION	DATE	DWN	APVD
	-	SEE SHEET 1	-	-	-

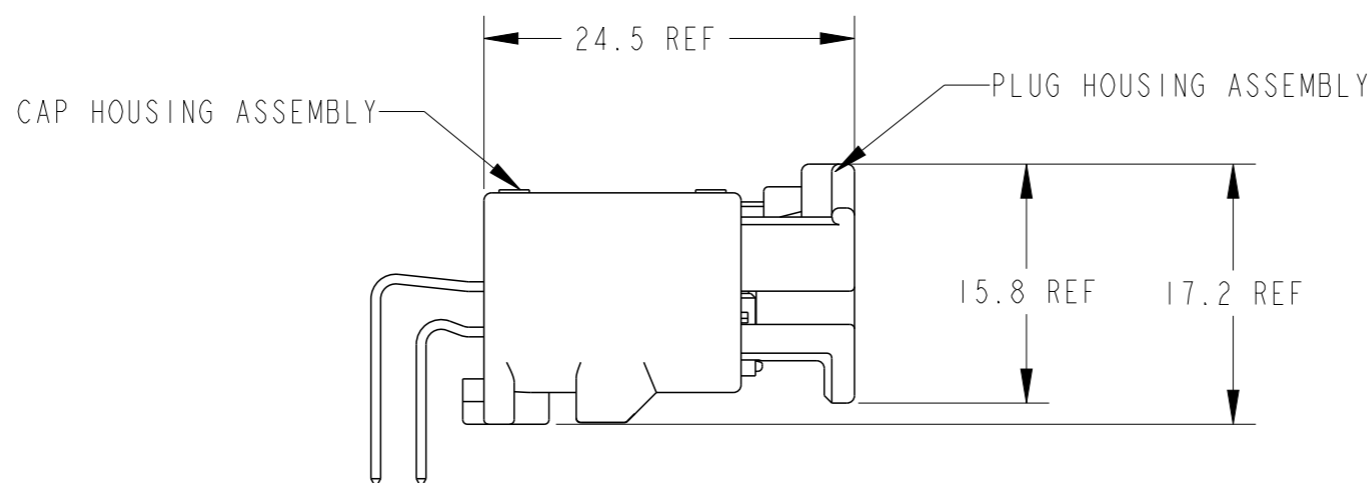
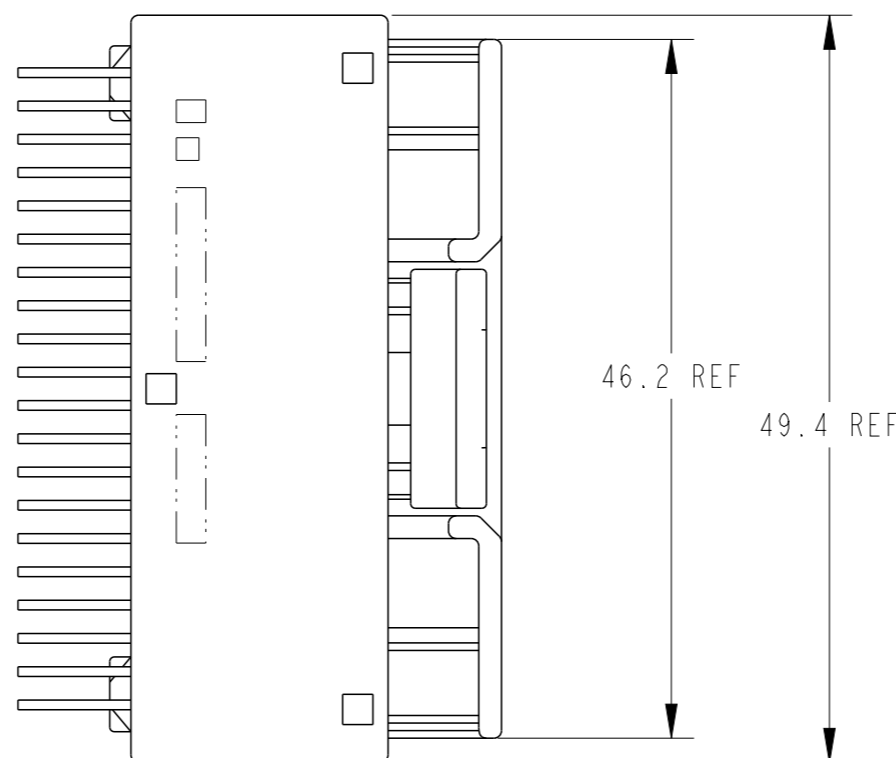

CAP ASSEMBLY & PLUG ASSEMBLY ENGAGEMENT DRAWING
 キャップアッセンブリ & プラグアッセンブリ 嵌合図

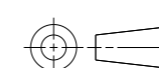
THIS DRAWING IS A CONTROLLED DOCUMENT.		DWN	08MAR00		 TE Connectivity
		CHK	10MAR00		
		APVD	10MAR00		
DIMENSIONS: 単位: 耗 mm		TOLERANCES UNLESS OTHERWISE SPECIFIED: ±0.3		NAME 名称 025 SERIES 40P (PCB H-TYPE) CAP HSG ASSY	
		一般公差 ±0.3		PRODUCT SPEC 製品規格 SEE SHEET 1 OF 3	
MATERIAL 材料 SEE SHEET 1 OF 3		FINISH 仕上 SEE SHEET 1 OF 3		APPLICATION SPEC 取付適用規格 SEE SHEET 1 OF 3	
		WEIGHT 重量 SEE SHEET 1 OF 3		SIZE 寸法 A3	CAGE CODE 番号 00779
		CUSTOMER DRAWING		DRAWING NO 番号 C-1318384	RESTRICTED TO
		SCALE 尺度 4:1		SHEET 3 OF 3	REV C5

Mouser Electronics

Authorized Distributor

Click to View Pricing, Inventory, Delivery & Lifecycle Information:

[TE Connectivity:](#)

[1318384-2](#)