

THIS DRAWING IS UNPUBLISHED. RELEASED FOR PUBLICATION
 © COPYRIGHT - By - ALL RIGHTS RESERVED.

LOC	DIST	REVISIONS					
		P	LTR	DESCRIPTION	DATE	DWN	APVD
G	14		P	REVISED PER ECO-14-015277	17FEB2015	NK	DR

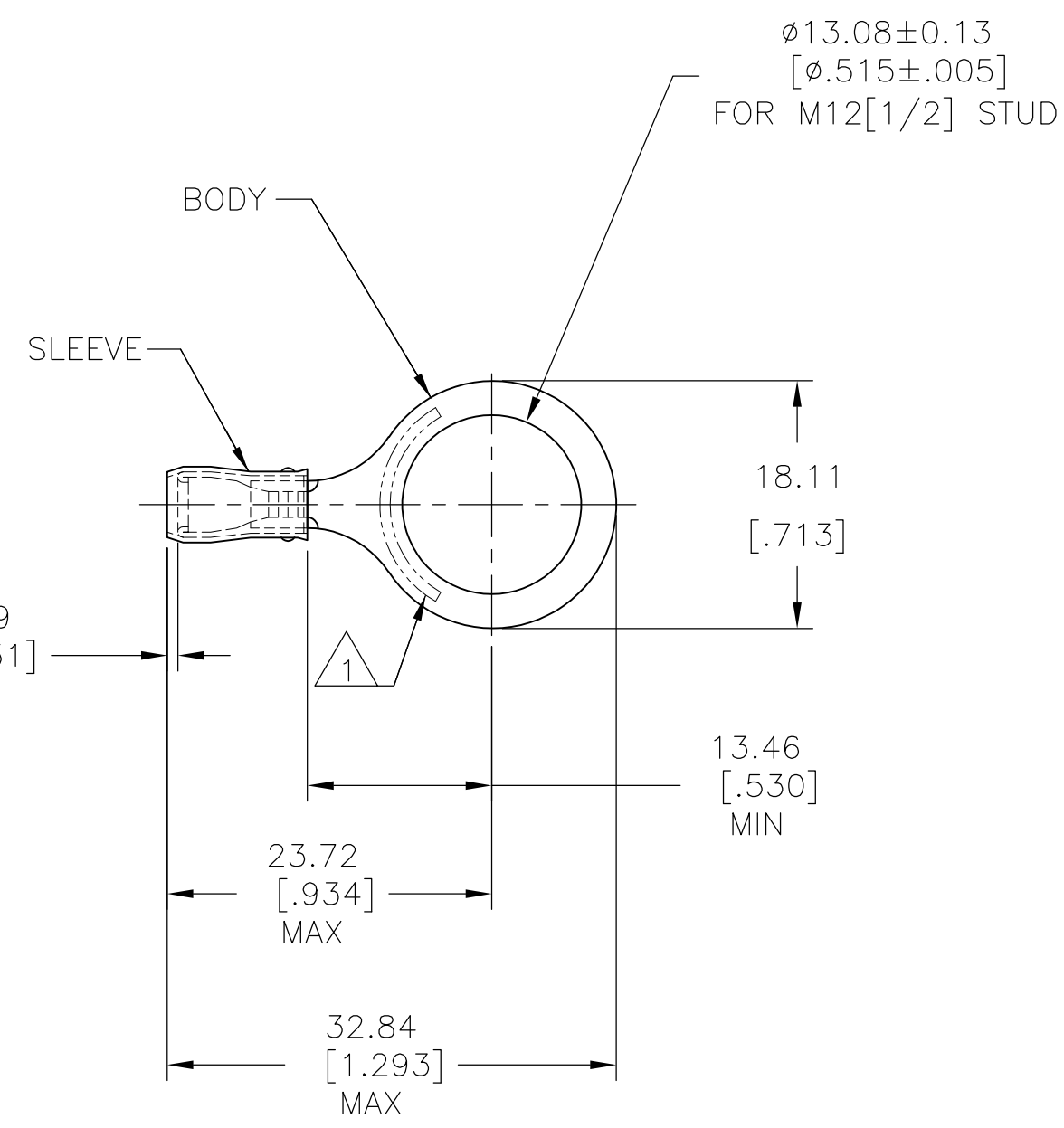

AMP WIRE RANGE	E13288 Listed	LR7189 Certified
22-16 AWG SOLID OR STRANDED	22-16 AWG SOLID OR STRANDED	22-16 AWG SOLID OR STRANDED

- 1 STAMP AMP 22-18* APPROX AS SHOWN
22-16 TERMINALS ARE STAMPED 22-18 IN
ACCORDANCE WITH MILITARY SPEC SAE AS7928
COMMERCIAL WIRE RANGE IS 22-16.
- 2 WIRE INSULATION DIA: 2.03-3.18[.080-.125].
- 3 TONGUE MATERIAL THK: 0.79±0.05[.031±.002].

-	100	LOOSE PIECE, BOX	8-328975-1
MS25036-151 CLASS 1 & 2	1000	LOOSE PIECE	328975
MILITARY P/N AND CLASS	QUANTITY	PACKAGE TYPE	PART NO

AMP INCORPORATED CUSTOMER SERVICE SYSTEMS		MAX RECOMMENDED OPERATING TEMPERATURE: 105°C[221°F] MAX	THIS DRAWING IS A CONTROLLED DOCUMENT.		DWN DK SCHRUM 9/8/93	TE Connectivity				
FOR ADDITIONAL PRODUCT INFORMATION OR COPIES OF DRAWINGS AND TECHNICAL DOCUMENTS	PRODUCT INFORMATION CENTER 1-800-522-6752	VOLTAGE RATING: 300 V MAX	DIMENSIONS: mm [INCHES]	TOLERANCES UNLESS OTHERWISE SPECIFIED:	CHK RE HERSEY 9/8/93					NAME TERMINAL, RING TONGUE, PIDG™, WIRE SIZE, 22-16 AWG
FOR APPLICATION TOOLING INFORMATION	TOOLING ASSISTANCE CENTER 1-800-722-1111	CIRCULAR MIL AREA: 0.26-1.65mm²[509-3,260] CIR MILS SOLID OR STRANDED		0 PLC ± - 1 PLC ± - 2 PLC ± 0.20[.008] 3 PLC ± - 4 PLC ± - ANGLES ± -	APVD ML ELLIS 9/8/93	PRODUCT SPEC UL 486A				
FOR ORDER ENTRY	1-800-526-5142		MATERIAL COPPER PER ASTM B-152 SLEEVE, RED NYLON	FINISH TIN PLATE PER ASTM B545	APPLICATION SPEC NOT AVAILABLE	SIZE A3	CAGE CODE 00779	DRAWING NO C-328975	RESTRICTED TO -	
CUSTOMER DRAWING					WEIGHT -	SCALE NTS	SHEET 1 OF 2	REV P		

THIS DRAWING IS UNPUBLISHED. RELEASED FOR PUBLICATION
 © COPYRIGHT - By - ALL RIGHTS RESERVED.

LOC	DIST	REVISIONS			
P	LTR	DESCRIPTION	DATE	DWN	APVD
G	14	-	SEE SHEET 1	-	-

AMP
WIRE RANGE

SEE TABLE
STRANDED

$\phi 13.08 \pm 0.13$
 $[\phi .515 \pm .005]$
 FOR M12[1/2] STUD

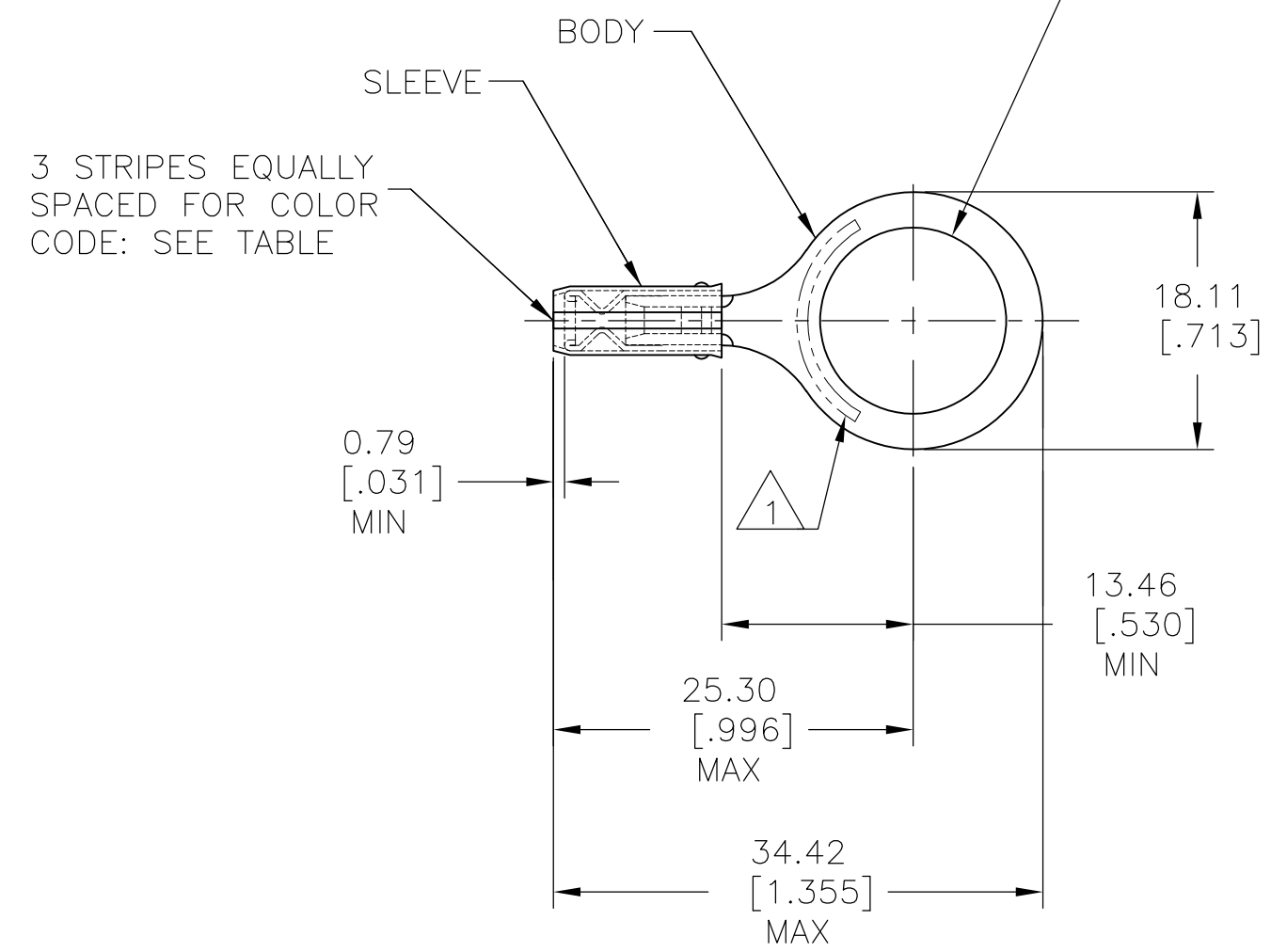

- 1 STAMP AMP APPROX AS SHOWN SEE TABLE BELOW.
- 2 WIRE INSULATION DIA: 0.97-2.79 [.038-.110] FOR 22 AWG
 1.17-2.79 [.046-.110] FOR 20 AWG
 1.42-2.79 [.056-.110] FOR 18 AWG
- 3 TONGUE MATERIAL THK: 0.79±0.05 [.031±.002].

MILITARY P/N AND CLASS	STRIPE COLOR	1	STAMPING	WIRE SIZE	QUANTITY	PACKAGE TYPE	PART NO
M7928/1-37 CLASS 1 & 2	WHITE	18*	18	1000	LOOSE PIECE	2-328975-3	
M7928/1-28 CLASS 1 & 2	RED	20*	20	1000	LOOSE PIECE	2-328975-2	
M7928/1-19 CLASS 1 & 2	GREEN	22*	22	1000	LOOSE PIECE	2-328975-1	

AMP INCORPORATED CUSTOMER SERVICE SYSTEMS		MAX RECOMMENDED OPERATING TEMPERATURE: 105°C [221°F] MAX	THIS DRAWING IS A CONTROLLED DOCUMENT.		DWN DK SCHRUM 9/8/93	STE TE Connectivity				
FOR ADDITIONAL PRODUCT INFORMATION OR COPIES OF DRAWINGS AND TECHNICAL DOCUMENTS	PRODUCT INFORMATION CENTER 1-800-522-6752	VOLTAGE RATING: 300 V MAX	DIMENSIONS: mm [INCHES]	TOLERANCES UNLESS OTHERWISE SPECIFIED:	CHK RE HERSEY 9/8/93				NAME	
FOR APPLICATION TOOLING INFORMATION	TOOLING ASSISTANCE CENTER 1-800-722-1111	WIRE RANGE: CIRC MIL AREA		0 PLC ± - 1 PLC ± - 2 PLC ± 0.20 [.008] 3 PLC ± - 4 PLC ± - ANGLES ± -	APVD ML ELLIS 9/8/93	TERMINAL, RING TONGUE, PIDG™, WIRE SIZE, 22-16 AWG				
FOR ORDER ENTRY	1-800-526-5142	STRANDED	MATERIAL COPPER PER ASTM B-152 SLEEVE, RED NYLON	FINISH TIN PLATE PER ASTM B545	PRODUCT SPEC -	APPLICATION SPEC NOT AVAILABLE	SIZE A3	CAGE CODE 00779	DRAWING NO C-328975	RESTRICTED TO -
CUSTOMER DRAWING					WEIGHT -	SCALE NTS	SHEET 2 OF 2	REV P		

Mouser Electronics

Authorized Distributor

Click to View Pricing, Inventory, Delivery & Lifecycle Information:

[TE Connectivity:](#)

[8-328975-1](#)