

DESIGNED FOR USE WITH RG-142/U (DOUBLE BRAID CABLE)	
CABLE ENTRY DIAMETER MINIMUM	
FERRULE	.216
HOUSING	.121
CONTACT	.042

REVISIONS			
REV	DESCRIPTION	DATE	APPROVED
01	RELEASED	12/15/92	<i>D. Cornelli</i>

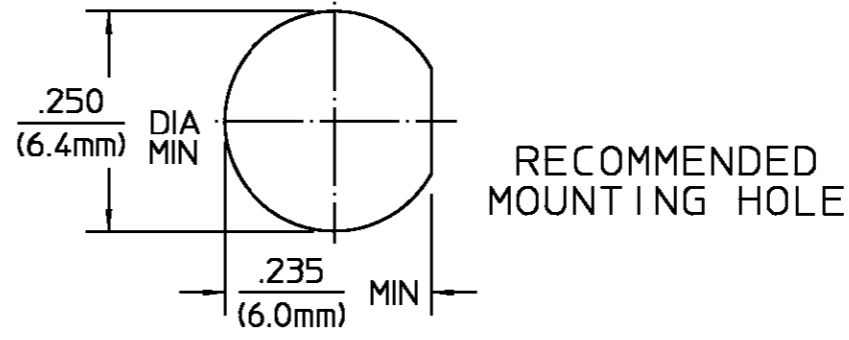

ELECTRICAL	MECHANICAL	ENVIRONMENTAL
Nominal Impedance (Ohms) <u>50</u>	Interface Dimensions MIL-STD-348A, Fig. <u>310.2</u>	Temperature Rating <u>-65°C to +165°C</u>
Frequency Range (GHz) DC to <u>12.4</u>	Recommended Mating	Vibration MIL-STD-202, Method 204, Condition D
Volt Rating (VRMS MAX) @ Sea Level <u>375</u>	Torque <u>N/A</u>	Shock MIL-STD-202, Method 213, Condition I
VSWR <u>1.30 : 1</u>	Mating Characteristics:	Thermal Shock MIL-STD-202, Method 107, Condition B,
Insertion Loss (dB MAX) <u>.06√f(GHz)</u>	Insertion (MAX lbs) <u>3.0</u>	Except High Temp shall be +85°C
RF Leakage (dB MIN) <u>-[60-f(GHz)]</u>	Withdrawal (MIN oz) <u>1.0</u>	Moisture Resistance MIL-STD-202, Method 106
Corona, 70,000 Ft (VRMS MIN) <u>250</u>	Force to Engage and Disengage (in-lbs MAX) <u>2.0</u>	Corrosion - MIL-STD-202, Method 101, Condition B, 5% salt spray
Dielectric Withstanding Voltage (VRMS MIN) @ Sea Level <u>1,000</u>	Center Contact Captivation	
Contact Resistance (Milliohms MAX)	Axial (lbs) <u>6.0</u>	
Center Contact <u>2.0</u>	Radial (in-oz) <u>N/A</u>	
Outer Contact <u>2.0</u>	Cable Retention	
Cable to Housing <u>0.5</u>	Axial Force (lbs MIN) <u>45.0</u>	
RF High Potential @ Sea Level (VRMS MIN @ 5 MHz) <u>670</u>	Torque (in-oz MIN) <u>N/A</u>	
I.R.(Megohms MIN) <u>10,000</u>	Weight (Grams) <u>TBD</u>	

COMPONENT	MATERIAL	FINISH
HOUSING MOUNTING NUT LOCKWASHER	STAINLESS STEEL PER ASTM-A484 AND ASTM- A582, TYPE 303	PASSIVATE PER ASTM-A380
DIELECTRIC	TFE FLUOROCARBON PER ASTM-D-1457	N/A
CENTER CONTACT	BERYLLIUM COPPER PER ASTM B 196, ALLOY C17300, CONDITION H	GOLD PLATE PER MIL-G-45204 OVER NICKEL PLATE PER QQ-N-290
FERRULE	COPPER OR BRASS ALLOY ROCKWELL F65 MAXIMUM	NICKEL PLATE PER QQ-N-290 OVER COPPER PLATE PER MIL-C-14550

UNLESS OTHERWISE SPECIFIED DIMENSIONS ARE IN INCHES TOLERANCE ON FRAC. DEC. ANGLES ± 1/64 ±.005 ± 1°	DRAWN BY <i>A. Davis</i> DATE 11/16/92	AMP Incorporated 140 Fourth Avenue Waltham, MA 02451-7599	
	CHECKED BY		
These drawings and specifications are the property of Omni Spectra Incorporated and shall not be reproduced or copied or used in whole or in part as the basis for the manufacture or sale of items without written permission.	APPD BY <i>D. Cornelli</i> 12/15/92	TITLE OSM LOW COST BULKHEAD CABLE JACK CRIMP ATTACHMENT	
	USE ASS'Y PROCEDURE 408-04661 NO. AP. (28-001)	SIZE B	CODE IDENT NO. 26805
		2834-7341-02	REV 01
	SCALE 4 : 1	SHEET 1 OF 1	

Mouser Electronics

Authorized Distributor

Click to View Pricing, Inventory, Delivery & Lifecycle Information:

[TE Connectivity:](#)

[1056447-1](#)