

# TPS74701-Q1 500-mA Low-Dropout Linear Regulator With Programmable Soft Start

## 1 Features

- Qualified for Automotive Applications
- AEC-Q100 Test Guidance With the Following:
  - Device Temperature Grade 1:  $-40^{\circ}\text{C}$  to  $125^{\circ}\text{C}$
  - Device HBM ESD Classification Level 2
  - Device CDM ESD Classification C4A
- $V_{\text{OUT}}$  Range: 0.8 V to 3.6 V
- Ultra-Low  $V_{\text{IN}}$  Range: 0.8 V to 5.5 V
- $V_{\text{BIAS}}$  Range: 2.7 V to 5.5 V
- Low Dropout: 50 mV Typical at 500 mA,  $V_{\text{BIAS}} = 5\text{ V}$
- Power Good (PG) Output Allows Supply Monitoring or Provides a Sequencing Signal for Other Supplies
- 2% Accuracy Over Line, Load, and Temperature
- Programmable Soft Start Provides Linear Voltage Start-Up
- $V_{\text{BIAS}}$  Permits Low  $V_{\text{IN}}$  Operation With Good Transient Response
- Stable With Any Output Capacitor  $\geq 2.2\ \mu\text{F}$
- Available in a Small 3-mm  $\times$  3-mm  $\times$  1-mm 10-Pin VSON Package

## 2 Applications

- FPGA Applications
- DSP Core and I/O Voltages
- Post-Regulation Applications
- Applications With Special Start-Up Time or Sequencing Requirements
- Hot-Swap and Inrush Controls

### Typical Application Circuit (Adjustable)

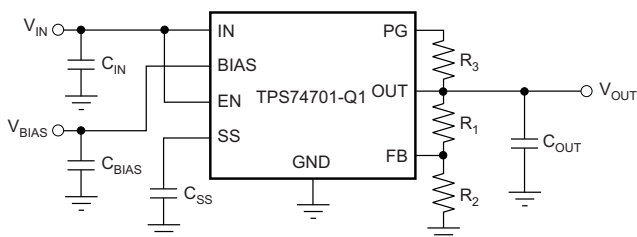

Copyright © 2016, Texas Instruments Incorporated

## 3 Description

The TPS74701-Q1 low-dropout (LDO) linear regulator provides an easy-to-use, robust power management solution for a wide variety of applications. User-programmable soft start minimizes stress on the input power source by reducing capacitive inrush current on start-up. The soft start is monotonic and well-suited for powering many different types of processors and ASICs. The enable input and power good output allow easy sequencing with external regulators. This complete flexibility permits the user to configure a solution that meets the sequencing requirements of FPGAs, DSPs, and other applications with special start-up requirements.

A precision reference and error amplifier deliver 2% accuracy over load, line, temperature, and process. The device is stable with any type of capacitor greater than or equal to  $2.2\ \mu\text{F}$ , and is fully specified from  $-40^{\circ}\text{C}$  to  $125^{\circ}\text{C}$ . The TPS74701-Q1 is offered in a small 3-mm  $\times$  3-mm 10-pin VSON package for compatibility with the [TPS74801-Q1](#).

### Device Information<sup>(1)</sup>

| PART NUMBER | PACKAGE   | BODY SIZE (NOM)          |
|-------------|-----------|--------------------------|
| TPS74701-Q1 | VSON (10) | 3.00 mm $\times$ 3.00 mm |

(1) For all available packages, see the orderable addendum at the end of the data sheet.

### Turnon Response

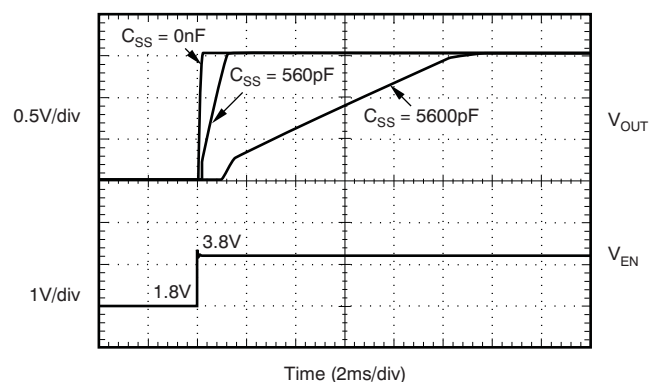

## Table of Contents

|   |  |
|---|--|
| <b>1 Features</b> ..... 1<br><b>2 Applications</b> ..... 1<br><b>3 Description</b> ..... 1<br><b>4 Revision History</b> ..... 2<br><b>5 Pin Configuration and Functions</b> ..... 3<br><b>6 Specifications</b> ..... 4<br>6.1 Absolute Maximum Ratings ..... 4<br>6.2 ESD Ratings..... 4<br>6.3 Recommended Operating Conditions ..... 4<br>6.4 Thermal Information ..... 5<br>6.5 Electrical Characteristics..... 5<br>6.6 Typical Characteristics ..... 7<br><b>7 Detailed Description</b> ..... 11<br>7.1 Overview ..... 11<br>7.2 Functional Block Diagram ..... 11<br>7.3 Feature Description..... 11<br>7.4 Device Functional Modes..... 14 | <b>8 Application and Implementation</b> ..... 15<br>8.1 Application Information..... 15<br>8.2 Typical Application ..... 15<br><b>9 Power Supply Recommendations</b> ..... 19<br><b>10 Layout</b> ..... 19<br>10.1 Layout Guidelines ..... 19<br>10.2 Layout Example ..... 19<br>10.3 Power Dissipation ..... 19<br><b>11 Device and Documentation Support</b> ..... 23<br>11.1 Device Support..... 23<br>11.2 Receiving Notification of Documentation Updates 23<br>11.3 Community Resources..... 23<br>11.4 Trademarks ..... 23<br>11.5 Electrostatic Discharge Caution..... 23<br>11.6 Glossary ..... 23<br><b>12 Mechanical, Packaging, and Orderable Information</b> ..... 23 |
|---|--|

## 4 Revision History

NOTE: Page numbers for previous revisions may differ from page numbers in the current version.

| Changes from Revision A (September 2010) to Revision B   | Page |
|--|------|
| <ul style="list-style-type: none"> <li>• Added <i>ESD Ratings</i> table, <i>Recommended Operating Conditions</i> table, <i>Feature Description</i> section, <i>Device Functional Modes</i>, <i>Application and Implementation</i> section, <i>Power Supply Recommendations</i> section, <i>Layout</i> section, <i>Device and Documentation Support</i> section, and <i>Mechanical, Packaging, and Orderable Information</i> section. ....</li> </ul> | 1    |
| <ul style="list-style-type: none"> <li>• Deleted <i>Ordering Information</i> table; see POA at the end of the data sheet.....</li> </ul>   | 1    |

## 5 Pin Configuration and Functions

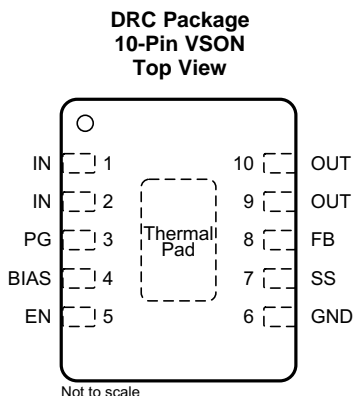

### Pin Functions

| PIN         |       | I/O | DESCRIPTION  |
|-------------|-------|-----|--|
| NAME        | NO.   |     |  |
| BIAS        | 4     | I   | Bias input voltage for error amplifier, reference, and internal control circuits.  |
| EN          | 5     | I   | Enable pin. Driving this pin high enables the regulator. Driving this pin low puts the regulator into shutdown mode. This pin must not be left unconnected.  |
| FB          | 8     | I   | Feedback pin. The feedback connection to the center tap of an external resistor divider network that sets the output voltage. This pin must not be left floating.  |
| GND         | 6     | —   | Ground   |
| IN          | 1, 2  | I   | Input to the device.   |
| OUT         | 9, 10 | O   | Regulated output voltage. A small capacitor (total typical capacitance $\geq 2.2 \mu\text{F}$ , ceramic) is needed from this pin to ground to assure stability.  |
| PG          | 3     | O   | Power Good pin. An open-drain, active-high output that indicates the status of $V_{\text{OUT}}$ . When $V_{\text{OUT}}$ exceeds the PG trip threshold, the PG pin goes into a high-impedance state. When $V_{\text{OUT}}$ is below this threshold the pin is driven to a low-impedance state. A pullup resistor from $10 \text{ k}\Omega$ to $1 \text{ M}\Omega$ must be connected from this pin to a supply of up to 5.5 V. The supply can be higher than the input voltage. Alternatively, the PG pin can be left unconnected if output monitoring is not necessary. |
| SS          | 7     | —   | Soft-Start pin. A capacitor connected on this pin to ground sets the start-up time. If this pin is left unconnected, the regulator output soft-start ramp time is typically $200 \mu\text{s}$ .  |
| Thermal Pad | —     | —   | Must be soldered to the ground plane for increased thermal performance.  |

## 6 Specifications

### 6.1 Absolute Maximum Ratings

At  $T_J = -40^{\circ}\text{C}$  to  $125^{\circ}\text{C}$ , unless otherwise noted. All voltages are with respect to GND.<sup>(1)</sup>

|                    |                                    | MIN                                     | MAX            | UNIT               |
|--------------------|------------------------------------|---|----------------|--------------------|
| $V_{IN}, V_{BIAS}$ | Input voltage                      | -0.3                                    | 6              | V                  |
| $V_{EN}$           | Enable voltage                     | -0.3                                    | 6              | V                  |
| $V_{PG}$           | Power good voltage                 | -0.3                                    | 6              | V                  |
| $V_{SS}$           | Soft-start voltage                 | -0.3                                    | 6              | V                  |
| $V_{FB}$           | Feedback voltage                   | -0.3                                    | 6              | V                  |
| $V_{OUT}$          | Output voltage                     | -0.3                                    | $V_{IN} + 0.3$ | V                  |
| $I_{PG}$           | PG sink current                    | 0                                       | 1.5            | mA                 |
| $I_{OUT}$          | Maximum output current             | Internally limited                      |                |                    |
|                    | Output short-circuit duration      | Indefinite                              |                |                    |
| $P_{DISS}$         | Continuous total power dissipation | See <a href="#">Thermal Information</a> |                |                    |
| $T_J$              | Operating junction temperature     | -40                                     | 125            | $^{\circ}\text{C}$ |
| $T_{stg}$          | Storage temperature                | -55                                     | 150            | $^{\circ}\text{C}$ |

(1) Stresses beyond those listed under *Absolute Maximum Ratings* may cause permanent damage to the device. These are stress ratings only and functional operation of the device at these conditions is not implied. Exposure to absolute-maximum-rated conditions for extended periods may affect device reliability.

### 6.2 ESD Ratings

|             |                         | VALUE   | UNIT       |
|-------------|-------------------------|---|------------|
| $V_{(ESD)}$ | Electrostatic discharge | Human-body model (HBM), per AEC Q100-002 <sup>(1)</sup> | $\pm 2000$ |
|             |                         | Charged-device model (CDM), per AEC Q100-011            | $\pm 500$  |

(1) AEC Q100-002 indicates that HBM stressing shall be in accordance with the ANSI/ESDA/JEDEC JS-001 specification.

### 6.3 Recommended Operating Conditions

over operating free-air temperature range (unless otherwise noted)

|                  |                                | MIN                                 | MAX      | UNIT               |
|------------------|--------------------------------|-------------------------------------|----------|--------------------|
| $V_{IN}$         | Input supply voltage           | $V_{OUT} + V_{DO} (V_{IN})$         |          | 5.5<br>V           |
| $V_{EN}$         | Enable supply voltage          | 0                                   | $V_{IN}$ | V                  |
| $V_{BIAS}^{(1)}$ | BIAS supply voltage            | $V_{OUT} + V_{DO} (V_{BIAS})^{(2)}$ |          | 5.5<br>V           |
| $V_{OUT}$        | Output voltage                 | 0.8                                 | 3.3      | V                  |
| $I_{OUT}$        | Output current                 | 0                                   | 500      | mA                 |
| $C_{OUT}$        | Output capacitor               | 2.2                                 |          | $\mu\text{F}$      |
| $C_{IN}^{(3)}$   | Input capacitor                | 1                                   |          | $\mu\text{F}$      |
| $C_{BIAS}$       | BIAS capacitor                 | 0.1                                 |          | $\mu\text{F}$      |
| $T_J$            | Operating junction temperature | -40                                 | 125      | $^{\circ}\text{C}$ |

(1) BIAS supply is required when  $V_{IN}$  is below  $V_{OUT} + 1.62$  V.

(2)  $V_{BIAS}$  has a minimum voltage of 2.7 V or  $V_{OUT} + V_{DO} (V_{BIAS})$ , whichever is higher.

(3) If  $V_{IN}$  and  $V_{BIAS}$  are connected to the same supply, the recommended minimum capacitor for the supply is 4.7  $\mu\text{F}$ .

## 6.4 Thermal Information

| THERMAL METRIC <sup>(1)(2)</sup> |  | TPS74701-Q1 | UNIT |
|----------------------------------|--|-------------|------|
|                                  |  | DRC (VSON)  |      |
|                                  |  | 10 PINS     |      |
| R <sub>θJA</sub>                 | Junction-to-ambient thermal resistance       | 50.4        | °C/W |
| R <sub>θJC(top)</sub>            | Junction-to-case (top) thermal resistance    | 70          | °C/W |
| R <sub>θJB</sub>                 | Junction-to-board thermal resistance         | 17.7        | °C/W |
| ψ <sub>JT</sub>                  | Junction-to-top characterization parameter   | 0.7         | °C/W |
| ψ <sub>JB</sub>                  | Junction-to-board characterization parameter | 16.9        | °C/W |
| R <sub>θJC(bot)</sub>            | Junction-to-case (bottom) thermal resistance | 5.9         | °C/W |

(1) For more information about traditional and new thermal metrics, see the [Semiconductor and IC Package Thermal Metrics](#) application report.

(2) For thermal estimates of this device based on PCB copper area, see the [TI PCB Thermal Calculator](#).

## 6.5 Electrical Characteristics

At V<sub>EN</sub> = 1.1 V, V<sub>IN</sub> = V<sub>OUT</sub> + 0.3 V, C<sub>BIAS</sub> = 0.1 μF, C<sub>IN</sub> = C<sub>OUT</sub> = 10 μF, C<sub>NR</sub> = 1 nF, I<sub>OUT</sub> = 50 mA, V<sub>BIAS</sub> = 5 V, and T<sub>J</sub> = –40°C to 125°C, unless otherwise noted. Typical values are at T<sub>J</sub> = 25°C.

| PARAMETER                          |   | TEST CONDITIONS  | MIN                                | TYP                   | MAX   | UNIT              |
|------------------------------------|---|--|------------------------------------|-----------------------|-------|-------------------|
| V <sub>IN</sub>                    | Input voltage range   |  | V <sub>OUT</sub> + V <sub>DO</sub> |                       | 5.5   | V                 |
| V <sub>BIAS</sub>                  | Bias pin voltage range  |  | 2.7                                |                       | 5.5   | V                 |
| V <sub>REF</sub>                   | Internal reference (Adj.)                                       | T <sub>J</sub> = 25°C  | 0.796                              | 0.8                   | 0.804 | V                 |
| V <sub>OUT</sub>                   | Output voltage range  | V <sub>IN</sub> = 5 V, I <sub>OUT</sub> = 500 mA   | V <sub>REF</sub>                   |                       | 3.6   | V                 |
|                                    | Accuracy <sup>(1)</sup>   | 2.97 V ≤ V <sub>BIAS</sub> ≤ 5.5 V,<br>50 mA ≤ I <sub>OUT</sub> ≤ 500 mA                         | –2%                                | ±0.5%                 | 2%    |                   |
| V <sub>OUT</sub> /V <sub>IN</sub>  | Line regulation   | V <sub>OUT</sub> (NOM) + 0.3 ≤ V <sub>IN</sub> ≤ 5.5 V   |                                    | 0.03                  |       | %/V               |
| V <sub>OUT</sub> /I <sub>OUT</sub> | Load regulation   | 50 mA ≤ I <sub>OUT</sub> ≤ 500 mA  |                                    | 0.09                  |       | %/A               |
| V <sub>DO</sub>                    | V <sub>IN</sub> dropout voltage <sup>(2)</sup>                  | I <sub>OUT</sub> = 500 mA,<br>V <sub>BIAS</sub> – V <sub>OUT</sub> (NOM) ≥ 1.62 V <sup>(3)</sup> |                                    | 50                    | 120   | mV                |
|                                    | V <sub>BIAS</sub> dropout voltage <sup>(2)</sup>                | I <sub>OUT</sub> = 500 mA, V <sub>IN</sub> = V <sub>BIAS</sub>                                   |                                    | 1.31                  | 1.39  | V                 |
| I <sub>CL</sub>                    | Current limit   | V <sub>OUT</sub> = 80% × V <sub>OUT</sub> (NOM)  | 800                                |                       | 1350  | mA                |
| I <sub>BIAS</sub>                  | Bias pin current  |  |                                    | 1                     | 2     | mA                |
| I <sub>SHDN</sub>                  | Shutdown supply current (I <sub>GND</sub> )                     | V <sub>EN</sub> ≤ 0.4 V  |                                    | 1                     | 50    | μA                |
| I <sub>FB</sub>                    | Feedback pin current  |  | –1                                 | 0.15                  | 1     | μA                |
| PSRR                               | Power-supply rejection (V <sub>IN</sub> to V <sub>OUT</sub> )   | 1 kHz, I <sub>OUT</sub> = 500 mA,<br>V <sub>IN</sub> = 1.8 V, V <sub>OUT</sub> = 1.5 V           |                                    | 60                    |       | dB                |
|                                    |   | 300 kHz, I <sub>OUT</sub> = 500 mA,<br>V <sub>IN</sub> = 1.8 V, V <sub>OUT</sub> = 1.5 V         |                                    | 30                    |       |                   |
|                                    | Power-supply rejection (V <sub>BIAS</sub> to V <sub>OUT</sub> ) | 1 kHz, I <sub>OUT</sub> = 500 mA,<br>V <sub>IN</sub> = 1.8 V, V <sub>OUT</sub> = 1.5 V           |                                    | 50                    |       | dB                |
|                                    |   | 300 kHz, I <sub>OUT</sub> = 500 mA,<br>V <sub>IN</sub> = 1.8 V, V <sub>OUT</sub> = 1.5 V         |                                    | 30                    |       |                   |
| Noise                              | Output noise voltage  | 100 Hz to 100 kHz,<br>I <sub>OUT</sub> = 500 mA, C <sub>SS</sub> = 0.001 μF                      |                                    | 25 × V <sub>OUT</sub> |       | μV <sub>RMS</sub> |
| t <sub>STR</sub>                   | Minimum start-up time   | R <sub>LOAD</sub> for I <sub>OUT</sub> = 1 A, C <sub>SS</sub> = open                             |                                    | 200                   |       | μs                |
| I <sub>SS</sub>                    | Soft-start charging current                                     | V <sub>SS</sub> = 0.4 V  |                                    | 440                   |       | nA                |
| V <sub>EN, HI</sub>                | Enable input high level   |  | 1.1                                |                       | 5.5   | V                 |
| V <sub>EN, LO</sub>                | Enable input low level  |  | 0                                  |                       | 0.4   | V                 |
| V <sub>EN, HYS</sub>               | Enable pin hysteresis   |  |                                    | 50                    |       | mV                |
| V <sub>EN, DG</sub>                | Enable pin deglitch time  |  |                                    | 20                    |       | μs                |
| I <sub>EN</sub>                    | Enable pin current  | V <sub>EN</sub> = 5 V  |                                    | 0.1                   | 1     | μA                |

(1) Adjustable devices tested at 0.8 V; resistor tolerance is not taken into account.

(2) Dropout is defined as the voltage from V<sub>IN</sub> to V<sub>OUT</sub> when V<sub>OUT</sub> is 3% below nominal.

(3) 1.62 V is a test condition of this device and can be adjusted by referring to [Figure 6](#).

**Electrical Characteristics (continued)**

At  $V_{EN} = 1.1\text{ V}$ ,  $V_{IN} = V_{OUT} + 0.3\text{ V}$ ,  $C_{BIAS} = 0.1\text{ }\mu\text{F}$ ,  $C_{IN} = C_{OUT} = 10\text{ }\mu\text{F}$ ,  $C_{NR} = 1\text{ nF}$ ,  $I_{OUT} = 50\text{ mA}$ ,  $V_{BIAS} = 5\text{ V}$ , and  $T_J = -40^\circ\text{C}$  to  $125^\circ\text{C}$ , unless otherwise noted. Typical values are at  $T_J = 25^\circ\text{C}$ .

| PARAMETER     |                                | TEST CONDITIONS                                      | MIN | TYP | MAX | UNIT             |
|---------------|--------------------------------|--|-----|-----|-----|------------------|
| $V_{IT}$      | PG trip threshold              | $V_{OUT}$ decreasing                                 | 85  | 90  | 94  | % $V_{OUT}$      |
| $V_{HYS}$     | PG trip hysteresis             |  |     | 3   |     | % $V_{OUT}$      |
| $V_{PG, LO}$  | PG output low voltage          | $I_{PG} = 1\text{ mA}$ (sinking), $V_{OUT} < V_{IT}$ |     |     | 0.3 | V                |
| $I_{PG, LKG}$ | PG leakage current             | $V_{PG} = 5.25\text{ V}$ , $V_{OUT} > V_{IT}$        |     | 0.1 | 1   | $\mu\text{A}$    |
| $T_J$         | Operating junction temperature |  | -40 |     | 125 | $^\circ\text{C}$ |
| $T_{SD}$      | Thermal shutdown temperature   | Shutdown, temperature increasing                     |     | 165 |     | $^\circ\text{C}$ |
|               |                                | Reset, temperature decreasing                        |     | 140 |     |                  |

## 6.6 Typical Characteristics

At  $T_J = 25^\circ\text{C}$ ,  $V_{IN} = V_{OUT(TYP)} + 0.3\text{ V}$ ,  $V_{BIAS} = 5\text{ V}$ ,  $I_{OUT} = 50\text{ mA}$ ,  $V_{EN} = V_{IN}$ ,  $C_{IN} = 1\ \mu\text{F}$ ,  $C_{BIAS} = 4.7\ \mu\text{F}$ , and  $C_{OUT} = 10\ \mu\text{F}$ , unless otherwise noted.

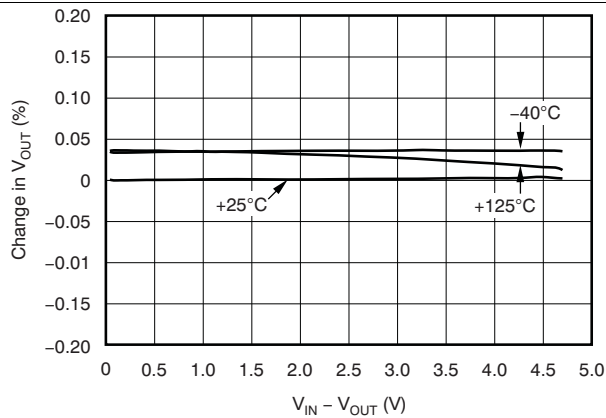

Figure 1.  $V_{IN}$  Line Regulation

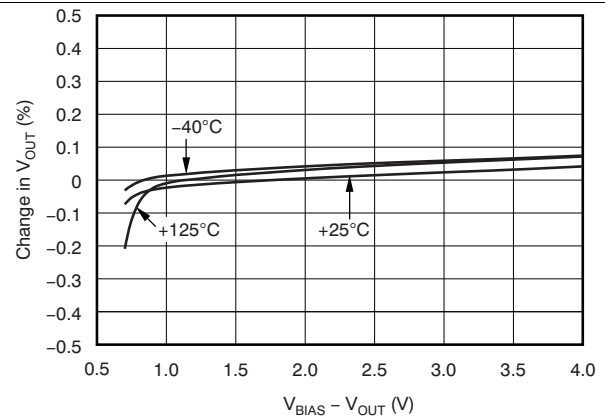

Figure 2.  $V_{BIAS}$  Line Regulation

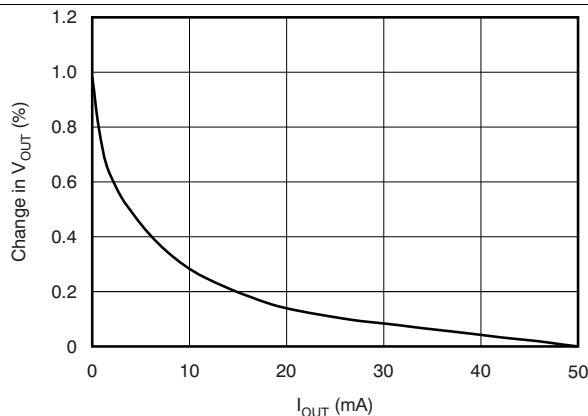

Figure 3. Load Regulation

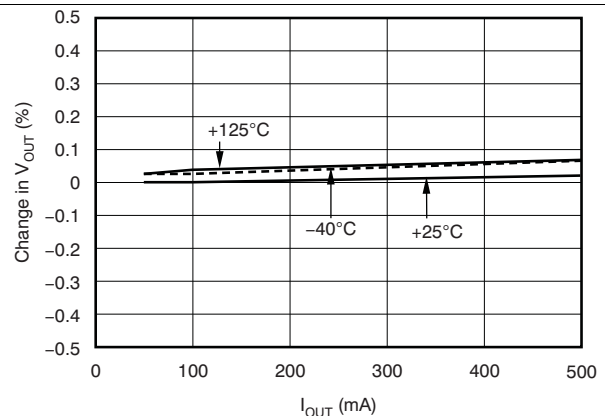

Figure 4. Load Regulation

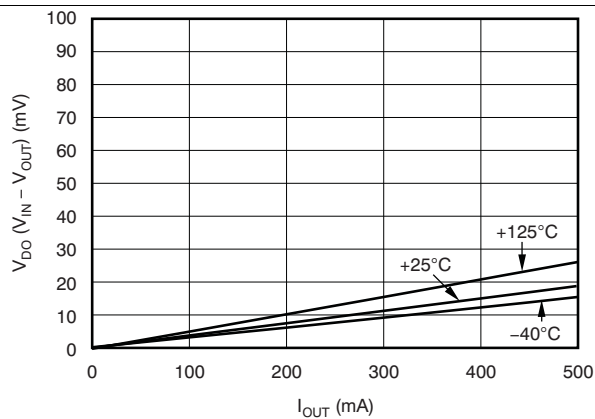

Figure 5. Dropout Voltage vs  $I_{OUT}$  and Temperature ( $T_J$ )

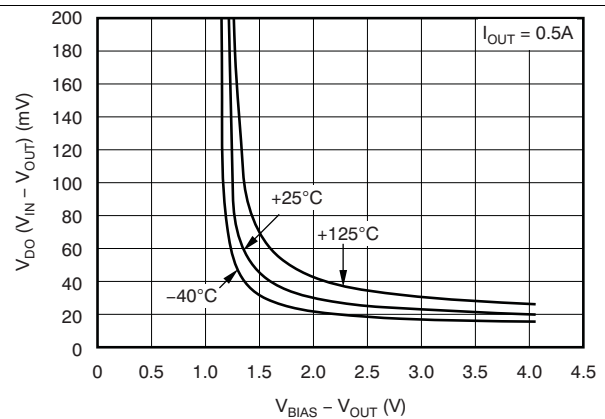

Figure 6. Dropout Voltage vs  $(V_{BIAS} - V_{OUT})$  and Temperature ( $T_J$ )

Typical Characteristics (continued)

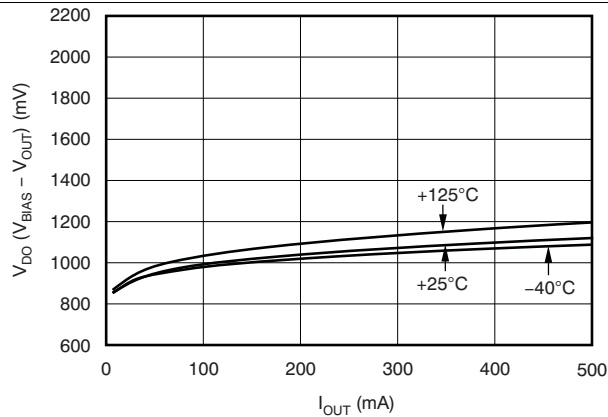

Figure 7.  $V_{BIAS}$  Dropout Voltage vs  $I_{OUT}$  and Temperature ( $T_J$ )

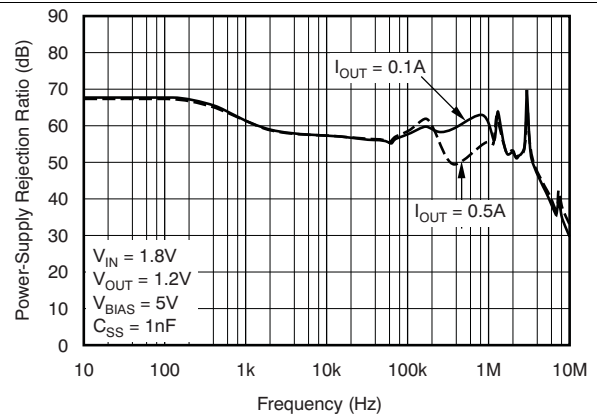

Figure 8.  $V_{BIAS}$  PSRR vs Frequency

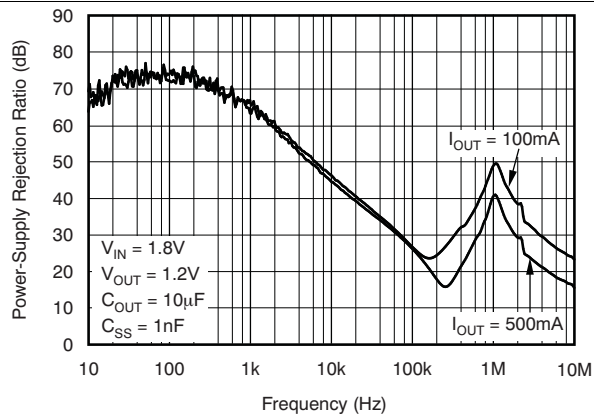

Figure 9.  $V_{IN}$  PSRR vs Frequency

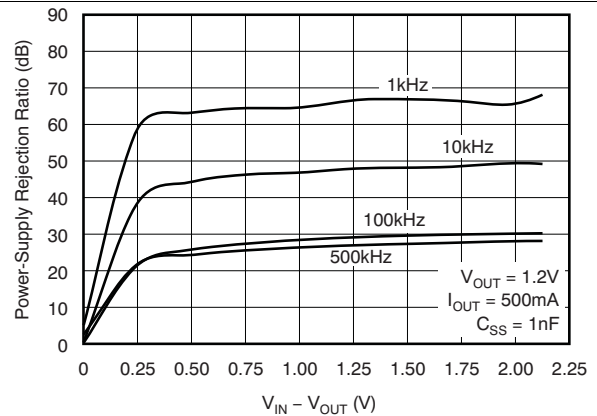

Figure 10.  $V_{IN}$  PSRR vs  $(V_{IN} - V_{OUT})$

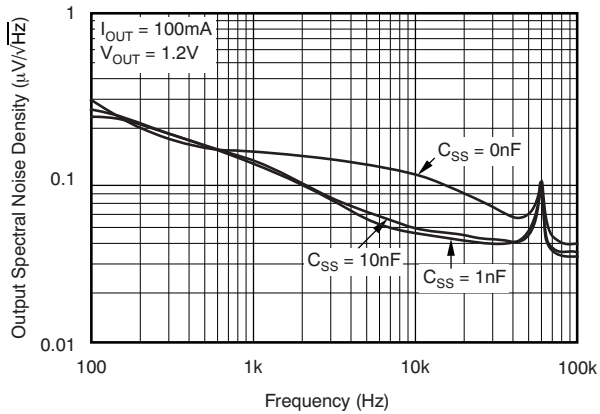

Figure 11. Noise Spectral Density

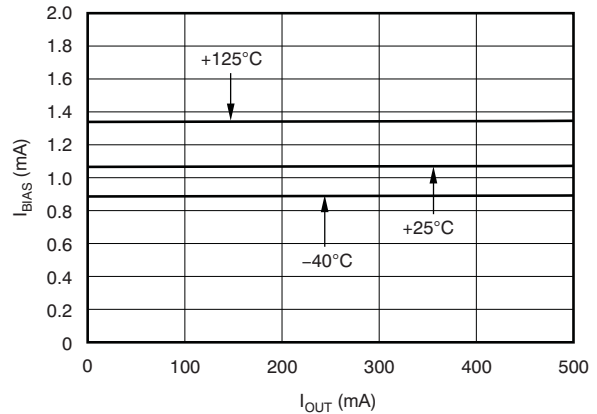

Figure 12. Bias Pin Current vs  $I_{OUT}$  and Temperature ( $T_J$ )



Typical Characteristics (continued)

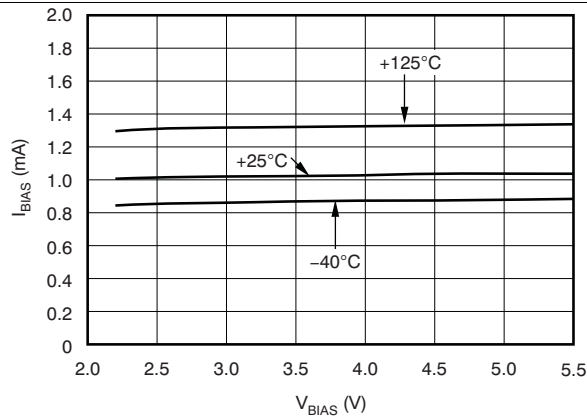

Figure 13. Bias Pin Current vs  $V_{BIAS}$  and Temperature ( $T_J$ )

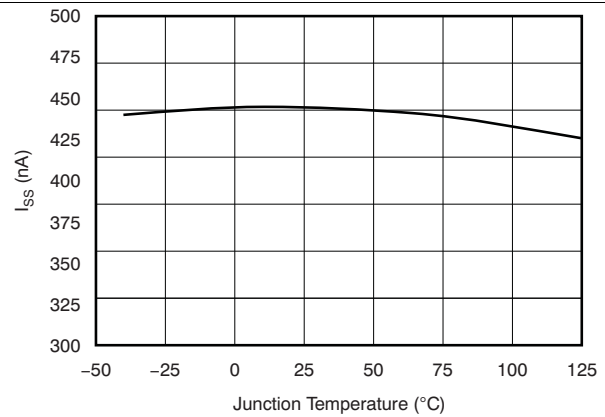

Figure 14. Soft-Start Charging Current ( $I_{SS}$ ) vs Temperature ( $T_J$ )

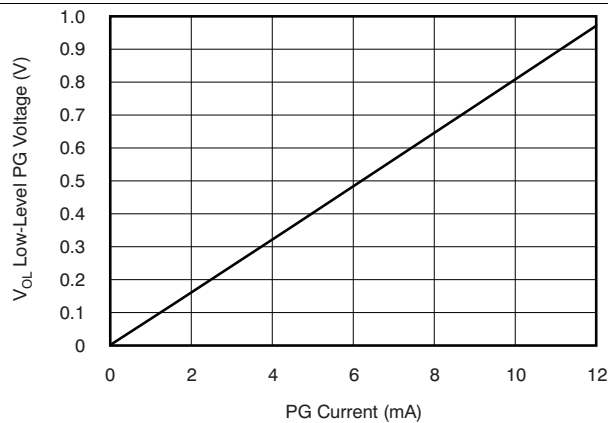

Figure 15. Low-Level PG Voltage vs Current

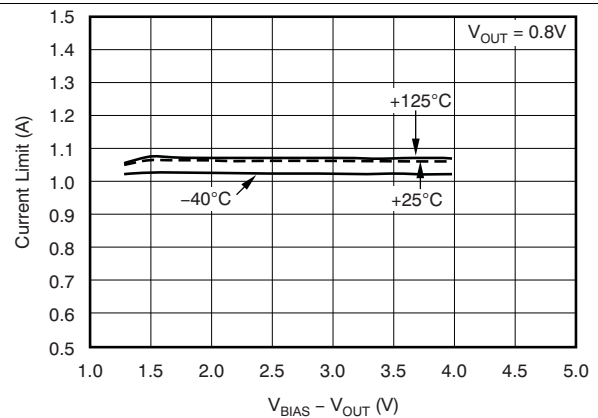
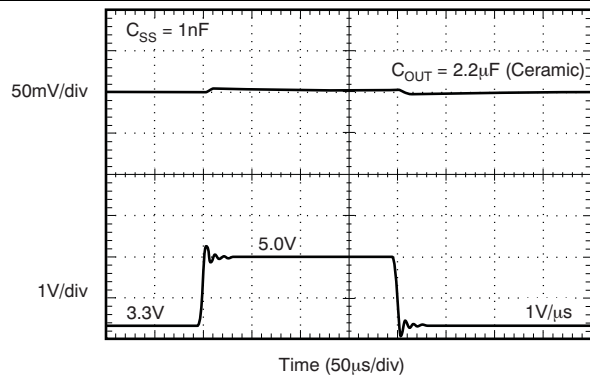
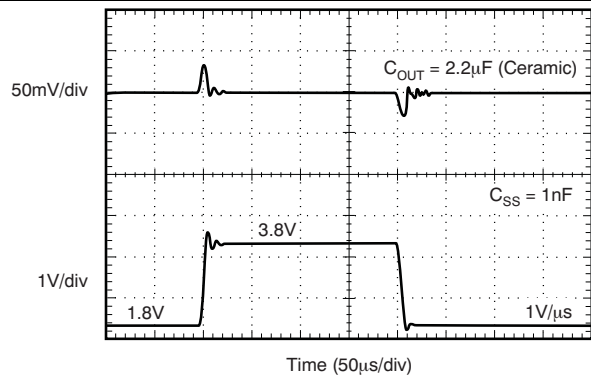

Figure 16. Current Limit vs ( $V_{BIAS} - V_{OUT}$ )



$I_{OUT} = 1\text{ A}$ ,  $V_{EN} = V_{IN} = 1.8\text{ V}$ ,  $V_{OUT} = 1.5\text{ V}$

Figure 17.  $V_{BIAS}$  Line Transient



$I_{OUT} = 1\text{ A}$ ,  $V_{EN} = V_{IN} = 1.8\text{ V}$ ,  $V_{OUT} = 1.5\text{ V}$

Figure 18.  $V_{IN}$  Line Transient

Typical Characteristics (continued)

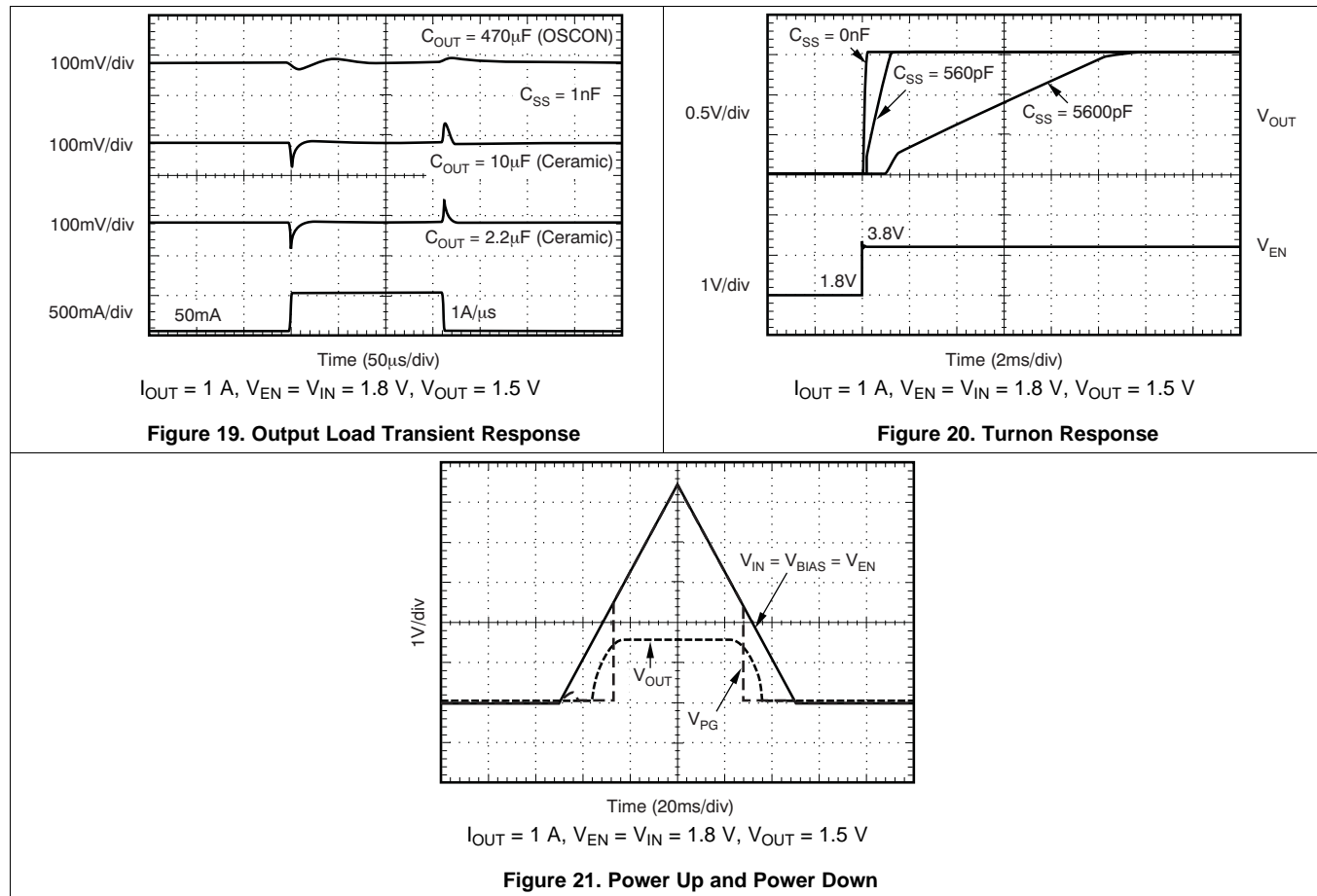

## 7 Detailed Description

### 7.1 Overview

The TPS74701-Q1 is a low-dropout regulator that features soft-start capability. This regulator use a low current bias input to power all internal control circuitry, allowing the NMOS pass transistor to regulate very low input and output voltages.

The use of an NMOS-pass FET offers several critical advantages for many applications. Unlike a PMOS topology device, the output capacitor has little effect on loop stability. This architecture allows the TPS74701 to be stable with any capacitor type of value 2.2  $\mu\text{F}$  or greater. Transient response is also superior to PMOS topologies, particularly for low  $V_{\text{IN}}$  applications.

The TPS74701-Q1 features a programmable voltage-controlled soft-start circuit that provides a smooth, monotonic start-up and limits start-up inrush currents that may be caused by large capacitive loads. A power good (PG) output is available to allow supply monitoring and sequencing of other supplies. An enable (EN) pin with hysteresis and deglitch allows slow-ramping signals to be used for sequencing the device. The low  $V_{\text{IN}}$  and  $V_{\text{OUT}}$  capability allows for inexpensive, easy-to-design, and efficient linear regulation between the multiple supply voltages often present in processor-intensive systems.

### 7.2 Functional Block Diagram

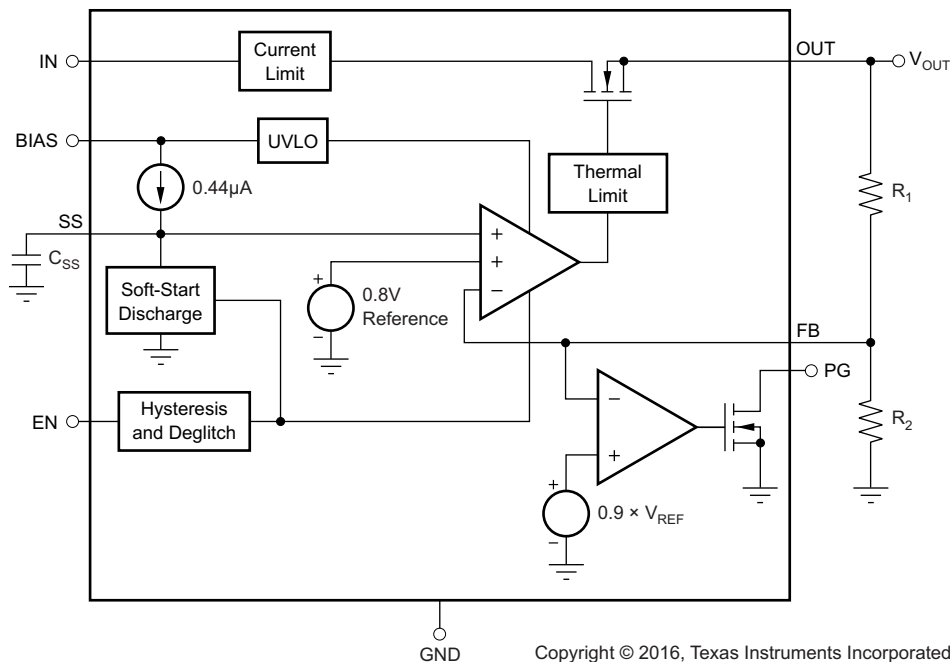

### 7.3 Feature Description

#### 7.3.1 Transient Response

The TPS74701-Q1 was designed to have excellent transient response for most applications with a small amount of output capacitance. In some cases, the transient response may be limited by the transient response of the input supply. This limitation is especially true in applications where the difference between the input and output is less than 300 mV. In this case, adding additional input capacitance improves the transient response much more than just adding additional output capacitance would do. With a solid input supply, adding additional output capacitance reduces undershoot and overshoot during a transient event; see [Figure 19](#). Because the TPS74701-Q1 is stable with output capacitors as low as 2.2  $\mu\text{F}$ , many applications may then need very little capacitance at the LDO output. For these applications, local bypass capacitance for the powered device may be sufficient to meet the transient requirements of the application. This design reduces the total solution cost by avoiding the need to use expensive, high-value capacitors at the LDO output.

## Feature Description (continued)

### 7.3.2 Dropout Voltage

The TPS74701-Q1 offers very low dropout performance, making it well-suited for high-current, low  $V_{IN}$ /low  $V_{OUT}$  applications. The low dropout of the TPS74701-Q1 allows the device to be used in place of a DC-DC converter and still achieve good efficiency. This feature provides designers with the power architecture for their applications to achieve the smallest, simplest, and lowest cost solution.

There are two different specifications for dropout voltage with the TPS74701-Q1. The first specification (shown in [Figure 22](#)) is referred to as  $V_{IN}$  Dropout and is used when an external bias voltage is applied to achieve low dropout. This specification assumes that  $V_{BIAS}$  is at least  $1.62\text{ V}^{(1)}$  above  $V_{OUT}$ , which is the case for  $V_{BIAS}$  when powered by a 3.3-V rail with 5% tolerance and with  $V_{OUT} = 1.5\text{ V}$ . If  $V_{BIAS}$  is higher than  $V_{OUT} + 1.62\text{ V}^{(1)}$ ,  $V_{IN}$  dropout is less than specified.

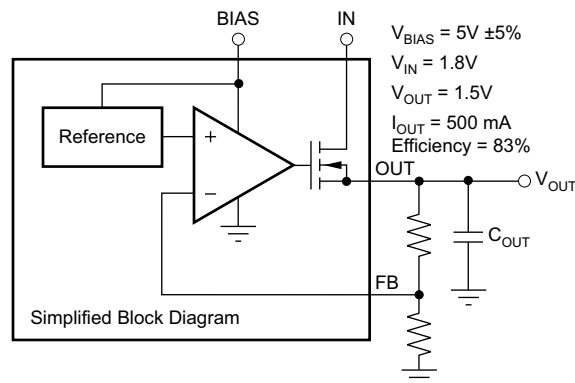

**Figure 22. Typical Application of the TPS74701-Q1 Using an Auxiliary Bias Rail**

The second specification (shown in [Figure 23](#)) is referred to as  $V_{BIAS}$  Dropout and applies to applications where  $IN$  and  $BIAS$  are tied together. This option allows the device to be used in applications where an auxiliary bias voltage is not available or low dropout is not required. Dropout is limited by  $BIAS$  in these applications because  $V_{BIAS}$  provides the gate drive to the pass FET; therefore,  $V_{BIAS}$  must be  $1.39\text{ V}$  above  $V_{OUT}$ . Because of this usage,  $IN$  and  $BIAS$  tied together easily consume huge power. Pay attention not to exceed the power rating of the IC package.

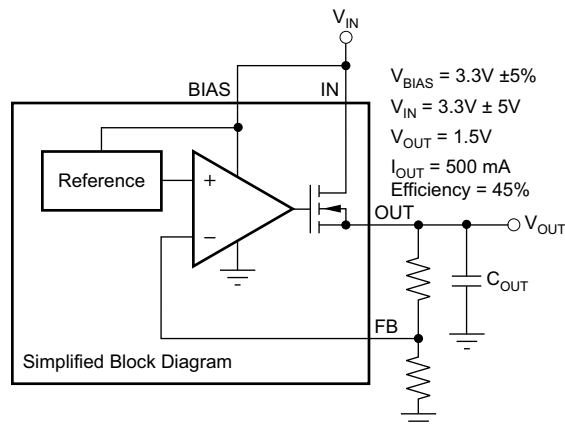

**Figure 23. Typical Application of the TPS74701-Q1 Without an Auxiliary Bias Rail**

(1)  $1.62\text{ V}$  is a test condition of this device and can be adjusted by referring to [Figure 6](#).

## Feature Description (continued)

### 7.3.3 Output Noise

The TPS74701-Q1 provides low output noise when a soft-start capacitor is used. When the device reaches the end of the soft-start cycle, the soft-start capacitor serves as a filter for the internal reference. By using a 0.001- $\mu\text{F}$  soft-start capacitor, the output noise is reduced by half and is typically 30  $\mu\text{V}_{\text{RMS}}$  for a 1.2-V output (10 Hz to 100 kHz). Further increasing  $C_{\text{SS}}$  has little effect on noise. Because most of the output noise is generated by the internal reference, the noise is a function of the set output voltage. The RMS noise with a 0.001- $\mu\text{F}$  soft-start capacitor is given in Equation 1:

$$V_{\text{N}}(\mu\text{V}_{\text{RMS}}) = 25 \left( \frac{\mu\text{V}_{\text{RMS}}}{\text{V}} \right) \times V_{\text{OUT}}(\text{V}) \quad (1)$$

The low output noise of the TPS74701-Q1 makes it a good choice for powering transceivers, PLLs, or other noise-sensitive circuitry.

### 7.3.4 Enable and Shutdown

The enable (EN) pin is active high and is compatible with standard digital signaling levels.  $V_{\text{EN}}$  below 0.4 V turns the regulator off, while  $V_{\text{EN}}$  above 1.1 V turns the regulator on. Unlike many regulators, the enable circuitry has hysteresis and deglitching for use with relatively slowly ramping analog signals. This configuration allows the TPS74701-Q1 to be enabled by connecting the output of another supply to the EN pin. The enable circuitry typically has 50 mV of hysteresis and a deglitch circuit to help avoid ON and OFF cycling as a result of small glitches in the  $V_{\text{EN}}$  signal.

The enable threshold is typically 0.8 V and varies with temperature and process variations. Temperature variation is approximately  $-1 \text{ mV}/^\circ\text{C}$ ; process variation accounts for most of the rest of the variation to the 0.4-V and 1.1-V limits. If precise turnon timing is required, a fast rise-time signal must be used to enable the TPS74701-Q1.

If not used, EN can be connected to either IN or BIAS. If EN is connected to IN, it must be connected as close as possible to the largest capacitance on the input to prevent voltage droops on that line from triggering the enable circuit.

### 7.3.5 Power Good

The power good (PG) pin is an open-drain output and can be connected to any 5.5 V or lower rail through an external pullup resistor. This pin requires at least 1.1 V on  $V_{\text{BIAS}}$  to have a valid output. The PG output is high-impedance when  $V_{\text{OUT}}$  is greater than  $V_{\text{IT}} + V_{\text{HYS}}$ . If  $V_{\text{OUT}}$  drops below  $V_{\text{IT}}$  or if  $V_{\text{BIAS}}$  drops below 1.9 V, the open-drain output turns on and pulls the PG output low. The PG pin also asserts when the device is disabled. The recommended operating condition of the PG pin sink current is up to 1 mA, so the pullup resistor for PG must be in the range of 10 k $\Omega$  to 1 M $\Omega$ . If output voltage monitoring is not needed, the PG pin can be left floating.

### 7.3.6 Internal Current Limit

The TPS74701-Q1 features a factory-trimmed, accurate current limit that is flat over temperature and supply voltage. The current limit allows the device to supply surges of up to 1 A and maintain regulation. The current limit responds in about 10  $\mu\text{s}$  to reduce the current during a short-circuit fault.

The internal current limit protection circuitry of the TPS74701-Q1 is designed to protect against overload conditions. It is not intended to allow operation above the rated current of the device. Continuously running the TPS74701-Q1 above the rated current degrades device reliability.

### 7.3.7 Thermal Protection

Thermal protection disables the output when the junction temperature rises to approximately 160 $^\circ\text{C}$ , allowing the device to cool. When the junction temperature cools to approximately 140 $^\circ\text{C}$ , the output circuitry is enabled. Depending on power dissipation, thermal resistance, and ambient temperature the thermal protection circuit may cycle ON and OFF. This cycling limits the dissipation of the regulator, protecting it from damage as a result of overheating.

## Feature Description (continued)

Activation of the thermal protection circuit indicates excessive power dissipation or inadequate heat sinking. For reliable operation, junction temperature should be limited to 125°C maximum. To estimate the margin of safety in a complete design (including heat sink), increase the ambient temperature until thermal protection is triggered; use worst-case loads and signal conditions. For good reliability, thermal protection should trigger at least 40°C above the maximum expected ambient condition of the application. This condition produces a worst-case junction temperature of 125°C at the highest expected ambient temperature and worst-case load.

The internal protection circuitry of the TPS74701-Q1 is designed to protect against overload conditions. It is not intended to replace proper heat sinking. Continuously running the TPS74701-Q1 into thermal shutdown degrades device reliability.

## 7.4 Device Functional Modes

### 7.4.1 Normal Operation

The device regulates to the nominal output voltage under the following conditions:

- The input voltage and bias voltage are both at least at the respective minimum specifications.
- The enable voltage has previously exceeded the enable rising threshold voltage and has not decreased below the enable falling threshold.
- The output current is less than the current limit.
- The device junction temperature is less than the maximum specified junction temperature.

### 7.4.2 Dropout Operation

If the input voltage is lower than the nominal output voltage plus the specified dropout voltage, but all other conditions are met for normal operation, the device operates in dropout mode. In this condition, the output voltage is the same as the input voltage minus the dropout voltage. The transient performance of the device is significantly degraded because the pass device is in a triode state and no longer controls the current through the LDO. Line or load transients in dropout can result in large output voltage deviations.

### 7.4.3 Disabled

The device is disabled under the following conditions:

- The input or bias voltages are below the respective minimum specifications.
- The enable voltage is less than the enable falling threshold voltage or has not yet exceeded the enable rising threshold.
- The device junction temperature is greater than the thermal shutdown temperature.

[Table 1](#) shows the conditions that lead to the different modes of operation.

**Table 1. Device Functional Mode Comparison**

| OPERATING MODE                                | PARAMETER                                |                       |                                  |                    |                     |
|---|--|-----------------------|----------------------------------|--------------------|---------------------|
|   | V <sub>IN</sub>                          | V <sub>EN</sub>       | V <sub>BIAS</sub>                | I <sub>OUT</sub>   | T <sub>J</sub>      |
| Normal mode                                   | $V_{IN} > V_{OUT(nom)} + V_{DO}(V_{IN})$ | $V_{EN} > V_{EN, HI}$ | $V_{BIAS} \geq V_{OUT} + 1.39 V$ | $I_{OUT} < I_{CL}$ | $T_J < 125^\circ C$ |
| Dropout mode                                  | $V_{IN} < V_{OUT(nom)} + V_{DO}(V_{IN})$ | $V_{EN} > V_{EN, HI}$ | $V_{BIAS} < V_{OUT} + 1.39 V$    | —                  | $T_J < 125^\circ C$ |
| Disabled mode (any true condition the device) | $V_{IN} < V_{IN(min)}$                   | $V_{EN} < V_{EN, LO}$ | $V_{BIAS} < V_{BIAS(min)}$       | —                  | $T_J > 165^\circ C$ |

## 8 Application and Implementation

### NOTE

Information in the following applications sections is not part of the TI component specification, and TI does not warrant its accuracy or completeness. TI's customers are responsible for determining suitability of components for their purposes. Customers should validate and test their design implementation to confirm system functionality.

### 8.1 Application Information

The TPS74701-Q1 device is a 500-mA low-dropout regulator with soft-start function integrated. Based on the end-application, different output voltage could be achieved with different values of external components.

### 8.2 Typical Application

Figure 24 illustrates the typical application circuit for the TPS74701-Q1 adjustable output device.

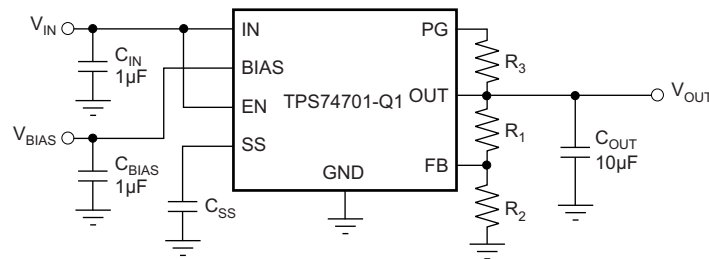

$$V_{OUT} = 0.8 \times \left( 1 + \frac{R_1}{R_2} \right)$$

Copyright © 2016, Texas Instruments Incorporated

Figure 24. Typical Application Circuit for the TPS74701-Q1

$R_1$  and  $R_2$  can be calculated for any output voltage using the formula shown in Figure 24. See Table 3 for sample resistor values of common output voltages. To achieve the maximum accuracy specifications,  $R_2$  must be less than or equal to 4.99 k $\Omega$ .

#### 8.2.1 Design Requirements

For this design example, use the parameters in Table 2.

Table 2. Design Parameters

| PARAMETER        | EXAMPLE VALUE   |
|------------------|-----------------|
| Input voltage    | 1.8 V $\pm$ 10% |
| Output voltage   | 1.5 V $\pm$ 3%  |
| Enable voltage   | 1.8 V $\pm$ 10% |
| BIAS voltage     | 3.3 V $\pm$ 10% |
| Output current   | 500 mA          |
| Output capacitor | 10 $\mu$ F      |
| Start-up time    | <2 ms           |

#### 8.2.2 Detailed Design Procedure

1. Select  $R_1$  and  $R_2$  based on the required output voltage. Table 3 gives example calculations for many common output voltages.
2. Select  $C_{SS}$  to be the highest capacitance while still achieving the desired start-up time. Table 4 gives examples of this calculation. Figure 26 gives examples of turnon response with different  $C_{SS}$  capacitor value.
3. Select a minimum of a 2.2- $\mu$ F ceramic output capacitor. Increased output capacitance helps the output load

transient response. [Figure 27](#) gives examples of the load transient response with different output capacitor values and types.

### 8.2.2.1 Input, Output, and Bias Capacitor Requirements

The device is designed to be stable for all available types and values of output capacitors greater than or equal to 2.2  $\mu\text{F}$ . The device is also stable with multiple capacitors in parallel, which can be of any type or value.

The capacitance required on the IN and BIAS pins strongly depends on the input supply source impedance. To counteract any inductance in the input, the minimum recommended capacitor for  $V_{\text{IN}}$  and  $V_{\text{BIAS}}$  is 1  $\mu\text{F}$ . If  $V_{\text{IN}}$  and  $V_{\text{BIAS}}$  are connected to the same supply, the recommended minimum capacitor for  $V_{\text{BIAS}}$  is 4.7  $\mu\text{F}$ . Good-quality, low-ESR capacitors should be used on the input; ceramic X5R and X7R capacitors are preferred. These capacitors must be placed as close to the pins as possible for optimum performance.

**Table 3. Standard 1% Resistor Values for Programming the Output Voltage<sup>(1)</sup>**

| $R_1$ (k $\Omega$ ) | $R_2$ (k $\Omega$ ) | $V_{\text{OUT}}$ (V) |
|---------------------|---------------------|----------------------|
| Short               | Open                | 0.8                  |
| 0.619               | 4.99                | 0.9                  |
| 1.13                | 4.53                | 1                    |
| 1.37                | 4.42                | 1.05                 |
| 1.87                | 4.99                | 1.1                  |
| 2.49                | 4.99                | 1.2                  |
| 4.12                | 4.75                | 1.5                  |
| 3.57                | 2.87                | 1.8                  |
| 3.57                | 1.69                | 2.5                  |
| 3.57                | 1.15                | 3.3                  |

(1)  $V_{\text{OUT}} = 0.8 \times (1 + R_1 / R_2)$ .

**Table 4. Standard Capacitor Values for Programming the Soft-Start Time<sup>(1)</sup>**

| $C_{\text{SS}}$    | SOFT-START TIME |
|--------------------|-----------------|
| Open               | 0.1 ms          |
| 270 pF             | 0.5 ms          |
| 560 pF             | 1 ms            |
| 2.7 nF             | 5 ms            |
| 5.6 nF             | 10 ms           |
| 0.01 $\mu\text{F}$ | 18 ms           |

(1)  $t_{\text{SS}}(\text{s}) = 0.8 \times C_{\text{SS}}(\text{F}) / 4.4 \times 10^{-7}$ .

### 8.2.2.2 Programmable Soft-Start

The TPS74701-Q1 features a programmable, monotonic, voltage-controlled soft start that is set with an external capacitor ( $C_{\text{SS}}$ ). This feature is important for many applications because it eliminates power-up initialization problems when powering FPGAs, DSPs, or other processors. The controlled voltage ramp of the output also reduces peak inrush current during start-up, minimizing start-up transient events to the input power bus.

To achieve a linear and monotonic soft start, the TPS74701-Q1 error amplifier tracks the voltage ramp of the external soft-start capacitor until the voltage exceeds the internal reference. The soft-start ramp time depends on the soft-start charging current ( $I_{\text{SS}}$ ), soft-start capacitance ( $C_{\text{SS}}$ ), and the internal reference voltage ( $V_{\text{REF}}$ ), and can be calculated using [Equation 2](#):

$$t_{\text{SS}} = \frac{(V_{\text{REF}} \times C_{\text{SS}})}{I_{\text{SS}}} \quad (2)$$

If large output capacitors are used, the device current limit ( $I_{\text{CL}}$ ) and the output capacitor may set the start-up time. In this case, the start-up time is given by [Equation 3](#):



$$t_{SSCL} = \frac{(V_{OUT(NOM)} \times C_{OUT})}{I_{CL(MIN)}}$$

where

- $V_{OUT(NOM)}$  is the nominal output voltage,
  - $C_{OUT}$  is the output capacitance, and
  - $I_{CL(MIN)}$  is the minimum current limit for the device.
- (3)

In applications where monotonic start-up is required, the soft-start time given by Equation 2 must be set greater than Equation 3.

The maximum recommended soft-start capacitor is 0.015  $\mu$ F. Larger soft-start capacitors can be used and do not damage the device; however, the soft-start capacitor discharge circuit may not be able to fully discharge the soft-start capacitor when enabled. Soft-start capacitors larger than 0.015  $\mu$ F could be a problem in applications where it is necessary to rapidly pulse the enable pin and still require the device to soft-start from ground.  $C_{SS}$  must be low-leakage; X7R, X5R, or C0G dielectric materials are preferred. See Table 4 for suggested soft-start capacitor values.

### 8.2.2.3 Sequencing Requirements

$V_{IN}$ ,  $V_{BIAS}$ , and  $V_{EN}$  can be sequenced in any order without causing damage to the device. However, for the soft-start function to work as intended, certain sequencing rules must be applied. Connecting EN to IN is acceptable for most applications, as long as  $V_{IN}$  is greater than 1.1 V and the ramp rate of  $V_{IN}$  and  $V_{BIAS}$  is faster than the set soft-start ramp rate. If the ramp rate of the input sources is slower than the set soft-start time, the output tracks the slower supply minus the dropout voltage until it reaches the set output voltage. If EN is connected to BIAS, the device soft-starts as programmed, provided that  $V_{IN}$  is present before  $V_{BIAS}$ . If  $V_{BIAS}$  and  $V_{EN}$  are present before  $V_{IN}$  is applied and the set soft-start time has expired, then  $V_{OUT}$  tracks  $V_{IN}$ . If the soft-start time has not expired, the output tracks  $V_{IN}$  until  $V_{OUT}$  reaches the value set by the charging soft-start capacitor. Figure 25 shows the use of an RC-delay circuit to hold off  $V_{EN}$  until  $V_{BIAS}$  has ramped. This technique can also be used to drive EN from  $V_{IN}$ . An external control signal can also be used to enable the device after  $V_{IN}$  and  $V_{BIAS}$  are present.

#### NOTE

When  $V_{BIAS}$  and  $V_{EN}$  are present and  $V_{IN}$  is not supplied, this device outputs approximately 50  $\mu$ A of current from OUT. Although this condition does not cause any damage to the device, the output current may charge up the OUT node if total resistance between OUT and GND (including external feedback resistors) is greater than 10 k $\Omega$ .

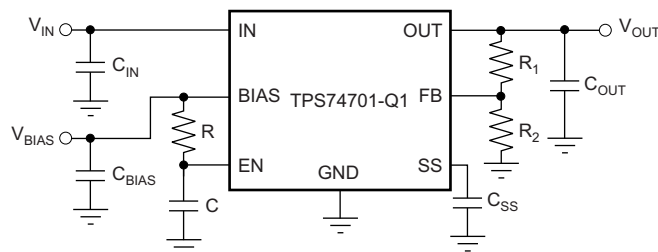

Copyright © 2016, Texas Instruments Incorporated

Figure 25. Soft-Start Delay Using an RC Circuit to Enable the Device

**8.2.3 Application Curves**

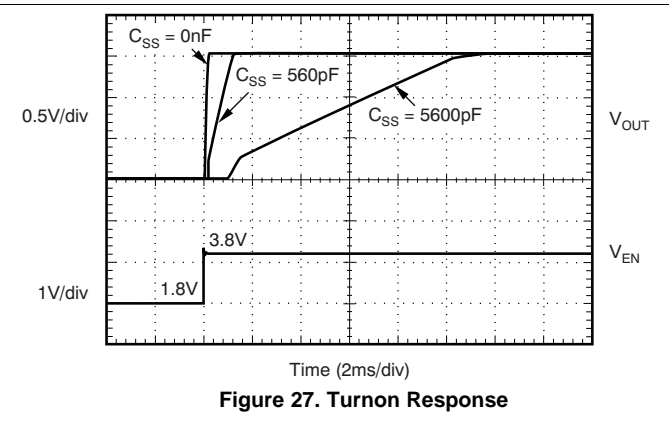
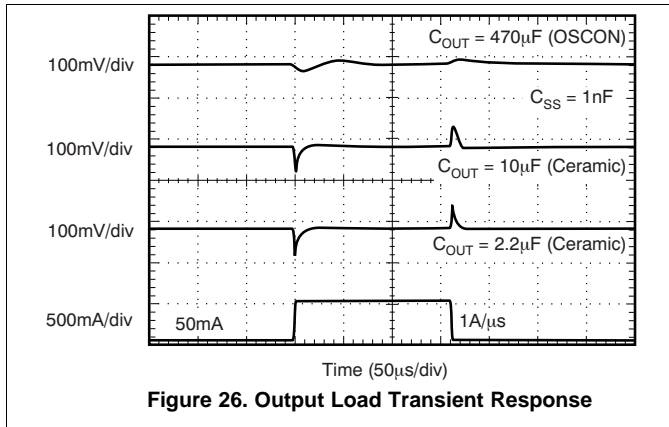

## 9 Power Supply Recommendations

The TPS74701-Q1 is designed to operate from an input voltage up to 5.5 V, provided the bias rail is at least 1.39 V higher than the input supply and dropout requirements are met. The bias rail and the input supply must both provide adequate headroom and current for the device to operate normally.

Connect a low-output impedance power supply directly to the IN pin of the TPS74701. This supply must have at least 1  $\mu\text{F}$  of capacitance near the IN pin for optimal performance. A supply with similar requirements must also be connected directly to the bias rail with a separate 1  $\mu\text{F}$  or larger capacitor. If the IN pin is tied to the bias pin, a minimum 4.7  $\mu\text{F}$  of capacitance is needed for performance. To increase the overall PSRR of the solution at higher frequencies, use a pi-filter or ferrite bead before the input capacitor.

## 10 Layout

### 10.1 Layout Guidelines

An optimal layout can greatly improve transient performance, PSRR, and noise. To minimize the voltage drop on the input of the device during load transients, the capacitance on IN and BIAS should be connected as close as possible to the device. This capacitance also minimizes the effects of parasitic inductance and resistance of the input source and can therefore improve stability. To achieve optimal transient performance and accuracy, the top side of  $R_1$  in Figure 24 should be connected as close as possible to the load. If BIAS is connected to IN, TI recommends connecting BIAS as close to the sense point of the input supply as possible. This connection minimizes the voltage drop on BIAS during transient conditions and can improve the turnon response.

### 10.2 Layout Example

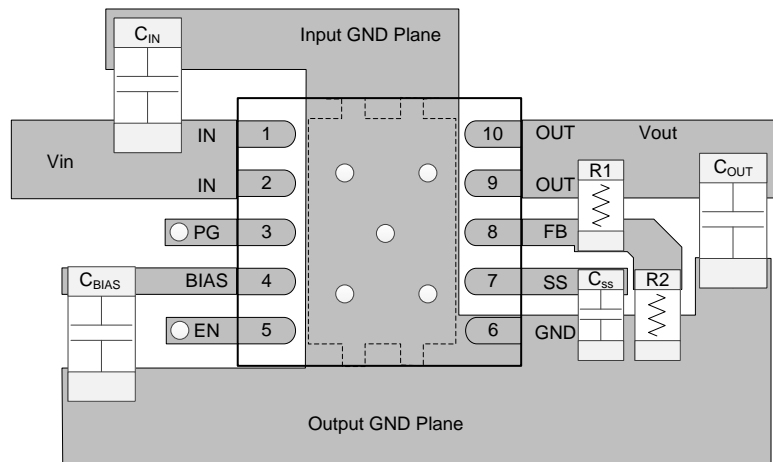

$C_{IN}$ ,  $C_{OUT}$ , and  $C_{BIAS}$  are 0603 case size capacitors, while  $C_{SS}$ ,  $R_1$ , and  $R_2$  are 0402 case size.

**Figure 28. Layout Recommendation**

### 10.3 Power Dissipation

Knowing the device power dissipation and proper sizing of the thermal plane that is connected to the thermal pad is critical to avoiding thermal shutdown and ensuring reliable operation. Power dissipation of the device depends on input voltage and load conditions and can be calculated using Equation 4:

$$P_D = (V_{IN} - V_{OUT}) \times I_{OUT} \quad (4)$$

Power dissipation can be minimized and greater efficiency can be achieved by using the lowest possible input voltage necessary to achieve the required output voltage regulation.

### Power Dissipation (continued)

On the VSON (DRC) package, the primary conduction path for heat is through the exposed pad to the printed-circuit board (PCB). The pad can be connected to ground or be left floating; however, it should be attached to an appropriate amount of copper PCB area to ensure the device does not overheat. The maximum junction to ambient thermal resistance depends on the maximum ambient temperature, maximum device junction temperature, and power dissipation of the device, and can be calculated using Equation 5:

$$R_{\theta JA} = \frac{(+125^{\circ}\text{C} - T_A)}{P_D} \tag{5}$$

Knowing the maximum  $R_{\theta JA}$  and system air flow, the minimum amount of PCB copper area needed for appropriate heat sinking can be calculated using Figure 29 through Figure 31.

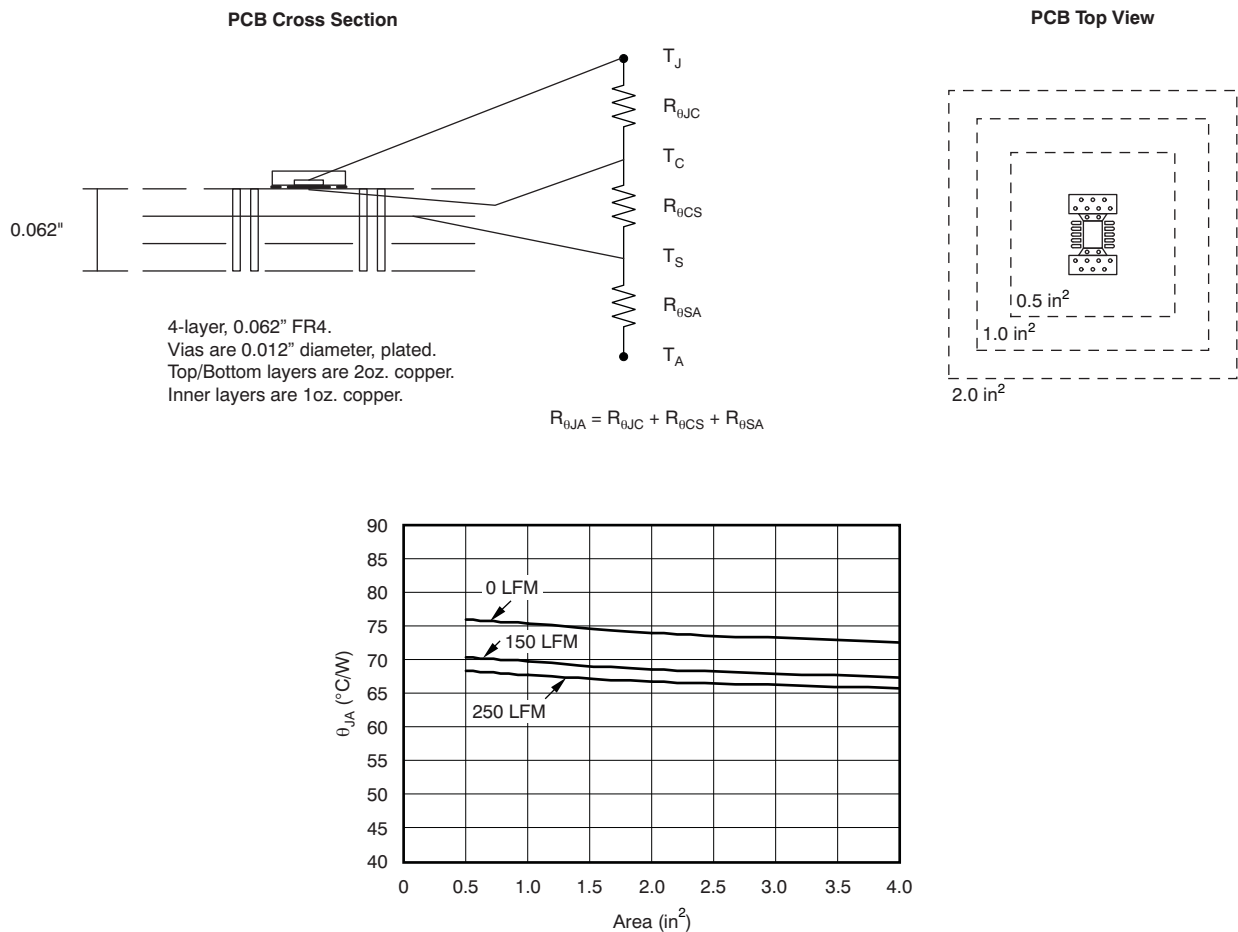

Figure 29. DRC (3 x 3 VSON) PCB Layout and Corresponding  $R_{\theta JA}$  Data, No Vias Under Thermal Pad

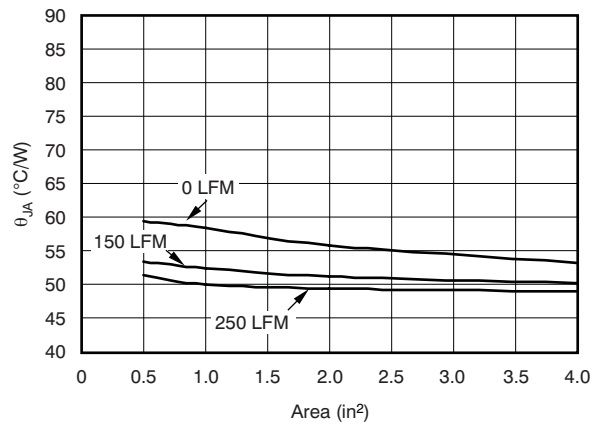
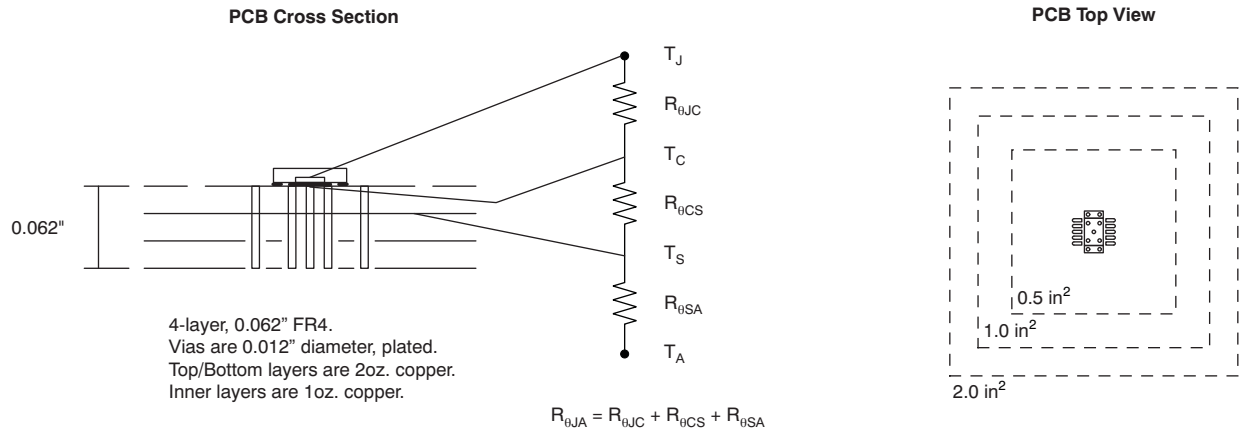

Figure 30. DRC (3 x 3 VSON) PCB Layout and Corresponding  $R_{\theta JA}$  Data, Vias Under Thermal Pad

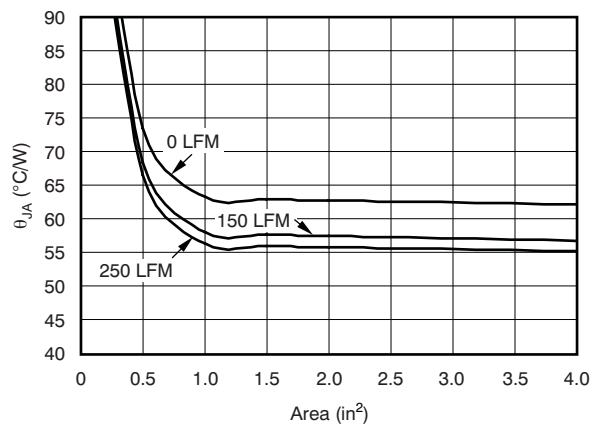
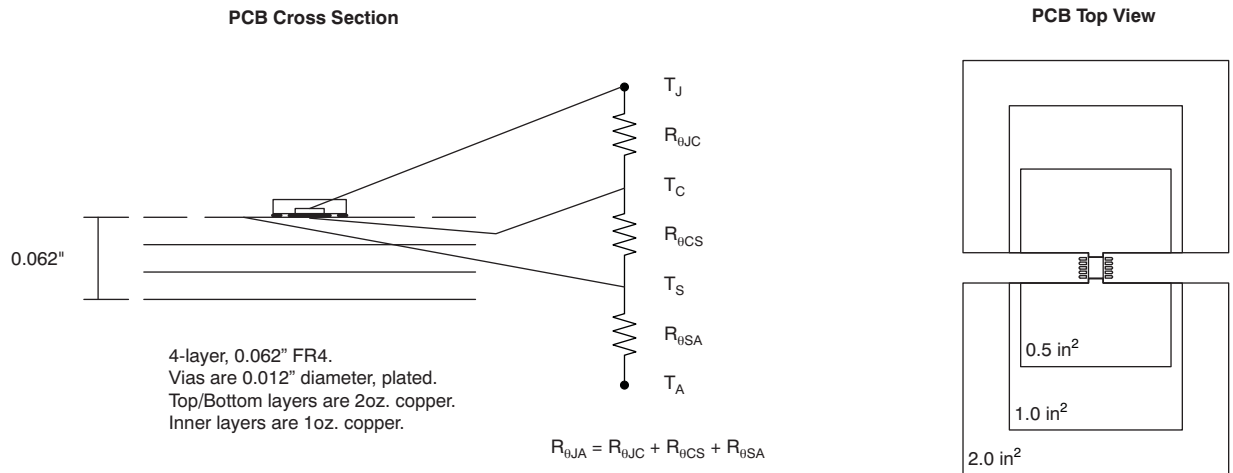

Figure 31. DRC (3 x 3 VSON) PCB Layout and Corresponding  $R_{\theta JA}$  Data, Top Layer Only

## 11 Device and Documentation Support

### 11.1 Device Support

#### 11.1.1 Development Support

For development support, see the following:

- [TPS74801-Q1](#)
- [TI PCB Thermal Calculator](#)

### 11.2 Receiving Notification of Documentation Updates

To receive notification of documentation updates, navigate to the device product folder on ti.com. In the upper right corner, click on *Alert me* to register and receive a weekly digest of any product information that has changed. For change details, review the revision history included in any revised document.

### 11.3 Community Resources

The following links connect to TI community resources. Linked contents are provided "AS IS" by the respective contributors. They do not constitute TI specifications and do not necessarily reflect TI's views; see TI's [Terms of Use](#).

**TI E2E™ Online Community** *TI's Engineer-to-Engineer (E2E) Community*. Created to foster collaboration among engineers. At e2e.ti.com, you can ask questions, share knowledge, explore ideas and help solve problems with fellow engineers.

**Design Support** *TI's Design Support* Quickly find helpful E2E forums along with design support tools and contact information for technical support.

### 11.4 Trademarks

E2E is a trademark of Texas Instruments.  
All other trademarks are the property of their respective owners.

### 11.5 Electrostatic Discharge Caution



These devices have limited built-in ESD protection. The leads should be shorted together or the device placed in conductive foam during storage or handling to prevent electrostatic damage to the MOS gates.

### 11.6 Glossary

[SLYZ022](#) — *TI Glossary*.

This glossary lists and explains terms, acronyms, and definitions.

## 12 Mechanical, Packaging, and Orderable Information

The following pages include mechanical, packaging, and orderable information. This information is the most current data available for the designated devices. This data is subject to change without notice and revision of this document. For browser-based versions of this data sheet, refer to the left-hand navigation.

**PACKAGING INFORMATION**

| Orderable Device | Status<br>(1) | Package Type | Package<br>Drawing | Pins | Package<br>Qty | Eco Plan<br>(2)            | Lead/Ball Finish<br>(6) | MSL Peak Temp<br>(3) | Op Temp (°C) | Device Marking<br>(4/5) | Samples |
|------------------|---------------|--------------|--------------------|------|----------------|----------------------------|-------------------------|----------------------|--------------|-------------------------|---------|
| TPS74701QDRCRQ1  | ACTIVE        | VSON         | DRC                | 10   | 3000           | Green (RoHS<br>& no Sb/Br) | NIPDAU                  | Level-3-260C-168 HR  | -40 to 125   | PAE                     | Samples |

(1) The marketing status values are defined as follows:

**ACTIVE:** Product device recommended for new designs.

**LIFEBUY:** TI has announced that the device will be discontinued, and a lifetime-buy period is in effect.

**NRND:** Not recommended for new designs. Device is in production to support existing customers, but TI does not recommend using this part in a new design.

**PREVIEW:** Device has been announced but is not in production. Samples may or may not be available.

**OBSELETE:** TI has discontinued the production of the device.

(2) **RoHS:** TI defines "RoHS" to mean semiconductor products that are compliant with the current EU RoHS requirements for all 10 RoHS substances, including the requirement that RoHS substance do not exceed 0.1% by weight in homogeneous materials. Where designed to be soldered at high temperatures, "RoHS" products are suitable for use in specified lead-free processes. TI may reference these types of products as "Pb-Free".

**RoHS Exempt:** TI defines "RoHS Exempt" to mean products that contain lead but are compliant with EU RoHS pursuant to a specific EU RoHS exemption.

**Green:** TI defines "Green" to mean the content of Chlorine (Cl) and Bromine (Br) based flame retardants meet JS709B low halogen requirements of <=1000ppm threshold. Antimony trioxide based flame retardants must also meet the <=1000ppm threshold requirement.

(3) MSL, Peak Temp. - The Moisture Sensitivity Level rating according to the JEDEC industry standard classifications, and peak solder temperature.

(4) There may be additional marking, which relates to the logo, the lot trace code information, or the environmental category on the device.

(5) Multiple Device Markings will be inside parentheses. Only one Device Marking contained in parentheses and separated by a "~" will appear on a device. If a line is indented then it is a continuation of the previous line and the two combined represent the entire Device Marking for that device.

(6) Lead/Ball Finish - Orderable Devices may have multiple material finish options. Finish options are separated by a vertical ruled line. Lead/Ball Finish values may wrap to two lines if the finish value exceeds the maximum column width.

**Important Information and Disclaimer:**The information provided on this page represents TI's knowledge and belief as of the date that it is provided. TI bases its knowledge and belief on information provided by third parties, and makes no representation or warranty as to the accuracy of such information. Efforts are underway to better integrate information from third parties. TI has taken and continues to take reasonable steps to provide representative and accurate information but may not have conducted destructive testing or chemical analysis on incoming materials and chemicals. TI and TI suppliers consider certain information to be proprietary, and thus CAS numbers and other limited information may not be available for release.

In no event shall TI's liability arising out of such information exceed the total purchase price of the TI part(s) at issue in this document sold by TI to Customer on an annual basis.

**OTHER QUALIFIED VERSIONS OF TPS74701-Q1 :**



- Catalog: [TPS74701](#)

NOTE: Qualified Version Definitions:

- Catalog - TI's standard catalog product

## TAPE AND REEL INFORMATION



### QUADRANT ASSIGNMENTS FOR PIN 1 ORIENTATION IN TAPE



\*All dimensions are nominal

| Device          | Package Type | Package Drawing | Pins | SPQ  | Reel Diameter (mm) | Reel Width W1 (mm) | A0 (mm) | B0 (mm) | K0 (mm) | P1 (mm) | W (mm) | Pin1 Quadrant |
|-----------------|--------------|-----------------|------|------|--------------------|--------------------|---------|---------|---------|---------|--------|---------------|
| TPS74701QDRCRQ1 | VSON         | DRC             | 10   | 3000 | 330.0              | 12.4               | 3.3     | 3.3     | 1.1     | 8.0     | 12.0   | Q2            |

TAPE AND REEL BOX DIMENSIONS



\*All dimensions are nominal

| Device          | Package Type | Package Drawing | Pins | SPQ  | Length (mm) | Width (mm) | Height (mm) |
|-----------------|--------------|-----------------|------|------|-------------|------------|-------------|
| TPS74701QDRCRQ1 | VSON         | DRC             | 10   | 3000 | 367.0       | 367.0      | 35.0        |

## GENERIC PACKAGE VIEW

DRC 10

VSON - 1 mm max height

PLASTIC SMALL OUTLINE - NO LEAD

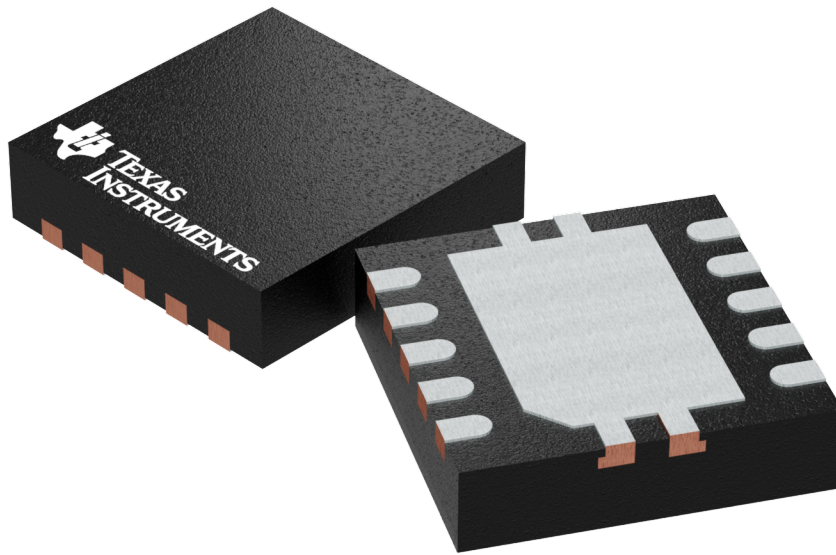

Images above are just a representation of the package family, actual package may vary.  
Refer to the product data sheet for package details.

4204102-3/M



# EXAMPLE BOARD LAYOUT

DRC0010J

VSON - 1 mm max height

PLASTIC SMALL OUTLINE - NO LEAD



LAND PATTERN EXAMPLE  
EXPOSED METAL SHOWN  
SCALE:20X



SOLDER MASK DETAILS

4218878/B 07/2018

NOTES: (continued)

4. This package is designed to be soldered to a thermal pad on the board. For more information, see Texas Instruments literature number SLUA271 ([www.ti.com/lit/sluea271](http://www.ti.com/lit/sluea271)).
5. Vias are optional depending on application, refer to device data sheet. If any vias are implemented, refer to their locations shown on this view. It is recommended that vias under paste be filled, plugged or tented.

# EXAMPLE STENCIL DESIGN

DRC0010J

VSON - 1 mm max height

PLASTIC SMALL OUTLINE - NO LEAD



SOLDER PASTE EXAMPLE  
BASED ON 0.125 mm THICK STENCIL

EXPOSED PAD 11:  
80% PRINTED SOLDER COVERAGE BY AREA  
SCALE:25X

4218878/B 07/2018

NOTES: (continued)

6. Laser cutting apertures with trapezoidal walls and rounded corners may offer better paste release. IPC-7525 may have alternate design recommendations.

## IMPORTANT NOTICE AND DISCLAIMER

TI PROVIDES TECHNICAL AND RELIABILITY DATA (INCLUDING DATASHEETS), DESIGN RESOURCES (INCLUDING REFERENCE DESIGNS), APPLICATION OR OTHER DESIGN ADVICE, WEB TOOLS, SAFETY INFORMATION, AND OTHER RESOURCES "AS IS" AND WITH ALL FAULTS, AND DISCLAIMS ALL WARRANTIES, EXPRESS AND IMPLIED, INCLUDING WITHOUT LIMITATION ANY IMPLIED WARRANTIES OF MERCHANTABILITY, FITNESS FOR A PARTICULAR PURPOSE OR NON-INFRINGEMENT OF THIRD PARTY INTELLECTUAL PROPERTY RIGHTS.

These resources are intended for skilled developers designing with TI products. You are solely responsible for (1) selecting the appropriate TI products for your application, (2) designing, validating and testing your application, and (3) ensuring your application meets applicable standards, and any other safety, security, or other requirements. These resources are subject to change without notice. TI grants you permission to use these resources only for development of an application that uses the TI products described in the resource. Other reproduction and display of these resources is prohibited. No license is granted to any other TI intellectual property right or to any third party intellectual property right. TI disclaims responsibility for, and you will fully indemnify TI and its representatives against, any claims, damages, costs, losses, and liabilities arising out of your use of these resources.

TI's products are provided subject to TI's Terms of Sale ([www.ti.com/legal/termsofsale.html](http://www.ti.com/legal/termsofsale.html)) or other applicable terms available either on [ti.com](http://ti.com) or provided in conjunction with such TI products. TI's provision of these resources does not expand or otherwise alter TI's applicable warranties or warranty disclaimers for TI products.

Mailing Address: Texas Instruments, Post Office Box 655303, Dallas, Texas 75265  
Copyright © 2020, Texas Instruments Incorporated