

### General Description

The ICS841664I is an optimized sRIO clock generator and a member of the family of high-performance clock solutions from IDT. The device uses a 25MHz parallel crystal to generate 125MHz and 156.25MHz clock signals, replacing solution requiring multiple oscillator and fanout buffer solutions. The device has excellent phase jitter (<1ps RMS) suitable to clock components requiring precise and low-jitter sRIO clock signals. Designed for telecom, networking and industrial application, the ICS841664I can also drive the high-speed sRIO SerDes clock inputs of communication processors, DSPs, switches and bridges.

### Features

- Four differential HCSL clock outputs: configurable for sRIO (125MHz or 156.25MHz) clock signals  
One REF\_OUT LVCMOS/LVTTL clock output
- Selectable crystal oscillator interface, 25MHz, 18pF parallel resonant crystal or LVCMOS/LVTTL single-ended reference clock input or LVCMOS/LVTTL single-ended input
- Supports the following output frequencies: 125MHz or 156.25MHz
- VCO: 625MHz
- Supports PLL bypass and output enable functions
- RMS phase jitter, using a 25MHz crystal (1.875MHz - 20MHz): 0.45ps (typical) @ 125MHz
- Full 3.3V power supply mode
- -40°C to 85°C ambient operating temperature
- Lead-free (RoHS 6) packaging

### Block Diagram

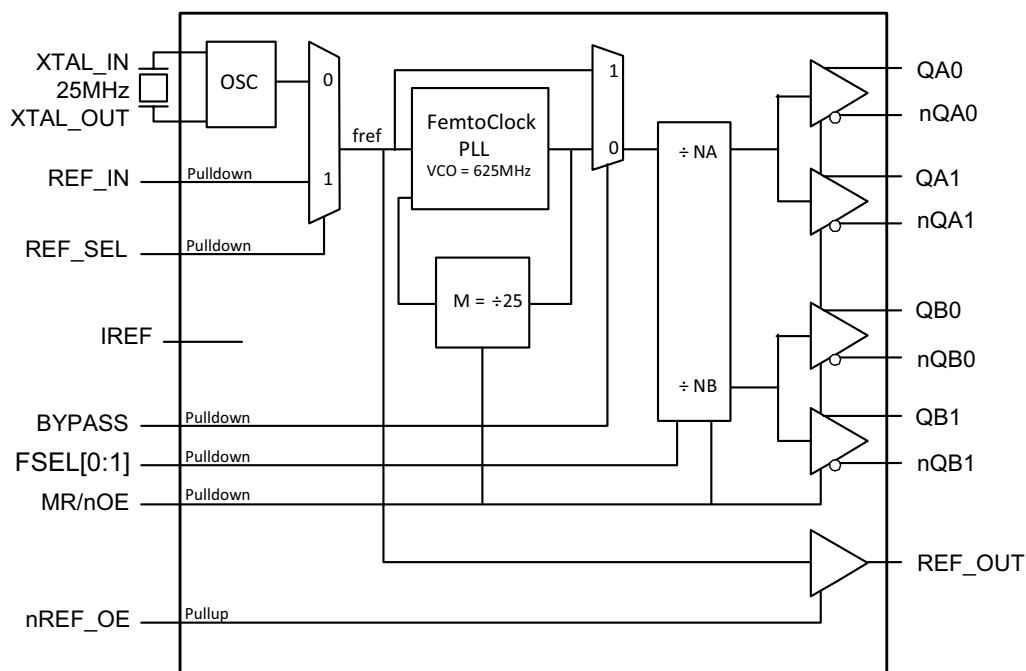

### Pin Assignment

VDD	1	28	IREF
REF_OUT	2	27	FSEL0
GND	3	26	FSEL1
QA0	4	25	QB0
nQA0	5	24	nQB0
VDDOA	6	23	VDDOB
GND	7	22	GND
QA1	8	21	QB1
nQA1	9	20	nQB1
nREF_OE	10	19	MR/nOE
BYPASS	11	18	VDD
REF_IN	12	17	XTAL_IN
REF_SEL	13	16	XTAL_OUT
VDDA	14	15	GND

**ICS841664I**  
**28-Lead TSSOP**  
**6.1mm x 9.7mm x 0.925mm**  
**package body**  
**G Package**  
**Top View**

## Pin Description and Pin Characteristic Tables

**Table 1. Pin Descriptions**

Number	Name	Type		Description
1, 18	V <sub>DD</sub>	Power		Core supply pins.
2	REF_OUT	Output		LVC MOS/LVTTL reference frequency clock output.
3, 7, 15, 22	GND	Power		Power supply ground.
4, 5, 8, 9	QA0, nQA0 QA1, nQA1	Output		Differential Bank A output pairs. HCSL interface levels.
6	V <sub>DDOA</sub>	Power		Output supply pin for Bank A outputs.
10	nREF_OE	Input	Pullup	Active low REF_OUT enable/disable. See Table 3E. LVC MOS/LVTTL interface levels.
11	BYPASS	Input	Pulldown	Selects PLL/PLL bypass mode. See Table 3C. LVC MOS/LVTTL interface levels.
12	REF_IN	Input	Pulldown	LVC MOS/LVTTL reference clock input.
13	REF_SEL	Input	Pulldown	Reference select, Selects the input reference source. See Table 3B. LVC MOS/LVTTL interface levels
14	V <sub>DDA</sub>	Power		Analog supply pin.
16, 17	XTAL_OUT, XTAL_IN	Input		Parallel resonant crystal interface. XTAL_OUT is the output, XTAL_IN is the input.
19	MR/nOE	Input	Pulldown	Active HIGH master reset. Active LOW output enable. When logic HIGH, the internal dividers are reset and the outputs are in high impedance. When logic LOW, the internal dividers and the outputs are enabled. See Table 3D. LVC MOS/LVTTL interface levels.
20, 21, 24, 25	nQB1, QB1 nQB0, QB0	Output		Differential Bank B output pairs. HCSL interface levels.
23	V <sub>DDOB</sub>	Power		Output supply pin for Bank B outputs.
26, 27	FSEL1, FSEL0	Input	Pulldown	Output frequency select pins. LVC MOS/LVTTL interface levels.
28	IREF	Output		HCSL current reference resistor output. A fixed precision resistor (475Ω) form this pin to ground provides a reference current used for differential current-mode QX[0:1], nQX[0:1] clock outputs.

NOTE: *Pullup and Pulldown* refer to internal input resistors. See Table 2, Pin Characteristics, for typical values.

**Table 2. Pin Characteristics**

Symbol	Parameter	Test Conditions	Minimum	Typical	Maximum	Units
C <sub>IN</sub>	Input Capacitance			4		pF
C <sub>PD</sub>	Power Dissipation Capacitance	V <sub>DD</sub> = 3.465V		4		pF
R <sub>PULLUP</sub>	Input Pullup Resistor			51		kΩ
R <sub>PULLDOWN</sub>	Input Pulldown Resistor			51		kΩ
R <sub>OUT</sub>	Output Impedance	REF_OUT	V <sub>DD</sub> = 3.465V	20		Ω

## Function Tables

**Table 3A. NA, NB FSELx Function Table ( $f_{ref} = 25\text{MHz}$ )**

Inputs			Outputs Frequency Settings	
FSEL1	FSEL0	M	QA[0:1], nQA[0:1]	QB[0:1], nQB[0:1]
0	0	25	VCO/5 (125MHz)	VCO/5 (125MHz)
0	1	25	VCO/5 (125MHz)	VCO/4 (156.25MHz)
1	0	25	VCO/5 (125MHz)	QB0:1 = L, nQB0:1 = H
1	1	25	VCO/4 (156.25MHz)	VCO/4 (156.25MHz)

**Table 3B. REF\_SEL Function Table**

Input	
REF_SEL	Input Reference
0	XTAL
1	REF_IN

**Table 3C. BYPASS Function Table**

Input	
BYPASS	PLL Configuration <sup>NOTE 1</sup>
0	PLL enabled
1	PLL bypassed (QA, QB = $f_{ref}/N_x$ , $x = A$ or $B$ )

NOTE 1: Asynchronous control.

**Table 3D. MR/nOE Function Table**

Input	
MR/nOE	Function <sup>NOTE 1</sup>
0	Outputs enabled
1	Internal dividers reset, outputs disabled (High impedance)

NOTE 1: Asynchronous control.

**Table 3E. nREF\_OE Function Table**

Input	
nREF_OE	Function <sup>NOTE 1</sup>
0	REF_OUT enabled
1	REF_OUT disabled (high impedance)

NOTE 1: Asynchronous control.

## Absolute Maximum Ratings

NOTE: Stresses beyond those listed under *Absolute Maximum Ratings* may cause permanent damage to the device. These ratings are stress specifications only. Functional operation of product at these conditions or any conditions beyond those listed in the *DC Characteristics* or *AC Characteristics* is not implied. Exposure to absolute maximum rating conditions for extended periods may affect product reliability.

Item	Rating
Supply Voltage, $V_{DD}$	4.6V
Inputs, $V_I$ XTAL_IN Other Inputs	0V to $V_{DD}$ -0.5V to $V_{DD} + 0.5V$
Outputs, $I_O$ Continuous Current REF_OUT Surge Current REF_OUT	$\pm 15mA$ $\pm 30mA$
Package Thermal Impedance, $\theta_{JA}$	64.5°C/W (0 mps)
Storage Temperature, $T_{STG}$	-65°C to 150°C

## DC Electrical Characteristics

**Table 4A. Power Supply DC Characteristics,  $V_{DD} = V_{DDOA} = V_{DDOB} = 3.3V \pm 5\%$ ,  $T_A = -40^\circ C$  to  $85^\circ C$**

Symbol	Parameter	Test Conditions	Minimum	Typical	Maximum	Units
$V_{DD}$	Core Supply Voltage		3.135	3.3	3.465	V
$V_{DDA}$	Analog Supply Voltage		$V_{DD} - 0.20$	3.3	3.465	V
$V_{DDOA}$ , $V_{DDOB}$	Output Supply Voltage		3.135	3.3	3.465	V
$I_{DD}$	Power Supply Current	No Load			80	mA
$I_{DDA}$	Analog Supply Current	No Load			20	mA
$I_{DDOA}$ , $I_{DDOB}$	Output Supply Current	No Load, $R_{REF} = 475\Omega \pm 1\%$			5	mA

**Table 4B. LVCMOS/LVTTL DC Characteristics,  $V_{DD} = 3.3V \pm 5\%$ ,  $T_A = -40^\circ C$  to  $85^\circ C$**

Symbol	Parameter	Test Conditions	Minimum	Typical	Maximum	Units
$V_{IH}$	Input High Voltage		2		$V_{DD} + 0.3$	V
$V_{IL}$	Input Low Voltage		-0.3		0.8	V
$I_{IH}$	Input High Current	REF_IN, REF_SEL, BYPASS, MR/nOE, FSEL0, FSEL1	$V_{DD} = V_{IN} = 3.465V$		150	$\mu A$
		nREF_OE	$V_{DD} = V_{IN} = 3.465V$		5	$\mu A$
$I_{IL}$	Input Low Current	REF_IN, REF_SEL, BYPASS, MR/nOE, FSEL0, FSEL1	$V_{DD} = 3.465V, V_{IN} = 0V$	-5		$\mu A$
		nREF_OE	$V_{DD} = 3.465V, V_{IN} = 0V$	-150		$\mu A$
$V_{OH}$	Output High Voltage; NOTE 1	REF_OUT	$V_{DD} = 3.465V$	2.6		V
$V_{OL}$	Output Low Voltage; NOTE 1	REF_OUT	$V_{DD} = 3.465V$		0.5	V

NOTE 1: Outputs termination with  $50\Omega$  to  $V_{DD}/2$ . See Parameter Measurement Information Section, *Output Load Test Circuit diagram*.

**Table 5. Crystal Characteristics**

Parameter	Test Conditions	Minimum	Typical	Maximum	Units
Mode of Oscillation		Fundamental			
Frequency			25		MHz
Equivalent Series Resistance (ESR)				50	$\Omega$
Shunt Capacitance				7	pF

NOTE: Characterized using an 18pF parallel resonant crystal.

## AC Electrical Characteristics

**Table 6A. LVCMOS AC Characteristics,  $V_{DD} = 3.3V \pm 5\%$ ,  $T_A = -40^\circ\text{C}$  to  $85^\circ\text{C}$** 

Symbol	Parameter	Test Conditions	Minimum	Typical	Maximum	Units
$f_{OUT}$	Output Frequency   REF_OUT			25		MHz
$t_R / t_F$	Output Rise/Fall Time	20% to 80%	1.5		2.2	ns
odc	Output Duty Cycle		47		53	%

**Table 6B. HCSL AC Characteristics,  $V_{DD} = V_{DDOA} = V_{DDOB} = 3.3V \pm 5\%$ ,  $T_A = -40^\circ\text{C}$  to  $85^\circ\text{C}$** 

Symbol	Parameter		Test Conditions	Minimum	Typical	Maximum	Units
$f_{OUT}$	Output Frequency		VCO/5		125		MHz
			VCO/4		156.25		MHz
$f_{jit}(\emptyset)$	RMS Phase Jitter (Random); NOTE 1		125MHz, Integration Range: 1.875MHz - 20MHz		0.45	0.55	ps
			156.25MHz, Integration Range: 1.875MHz - 20MHz		0.41	0.54	ps
$f_{jit}(cc)$	Cycle-to-Cycle Jitter; NOTE 3					60	ps
$t_{sk}(o)$	Output Skew; NOTE 2, 3	QAx, nQAx, QBx, nQBx				140	ps
$t_L$	PLL Lock Time					100	ms
$V_{HIGH}$	Voltage High			650	700	950	mV
$V_{LOW}$	Voltage Low			-150		150	mV
$V_{OVS}$	Max. Voltage, Overshoot					0.3	V
$V_{UDS}$	Min. Voltage, Undershoot			-0.3			V
$V_{RB}$	Ringback Voltage					0.2	V
$V_{CROSS}$	Absolute Crossing Voltage			200		550	mV
$\Delta V_{CROSS}$	Total Variation of $V_{CROSS}$ over all edges					160	mV
$t_R / t_F$	Output Rise/Fall Time	QAx, nQAx, QBx, nQBx	measured between 0.175V to 0.525V	100		700	ps
$\Delta t_R / \Delta t_F$	Rise/Fall Time Variation					125	ps
odc	Output Duty Cycle	QAx, nQAx, QBx, nQBx		47		53	%

NOTE: Electrical parameters are guaranteed over the specified ambient operating temperature range, which is established when the device is mounted in a test socket with maintained transverse airflow greater than 500 lpm. The device will meet specifications after thermal equilibrium has been reached under these conditions.

NOTE: All measurements are taken at 125MHz and 156.25MHz.

NOTE 1: Please refer to the Phase Noise Plot.

NOTE 2: Defined as skew between outputs at the same supply voltage and with equal load conditions. Measured at the differential cross points.

NOTE 3: This parameter is defined in accordance with JEDEC Standard 65.

### Typical Phase Noise at 125MHz At 3.3V

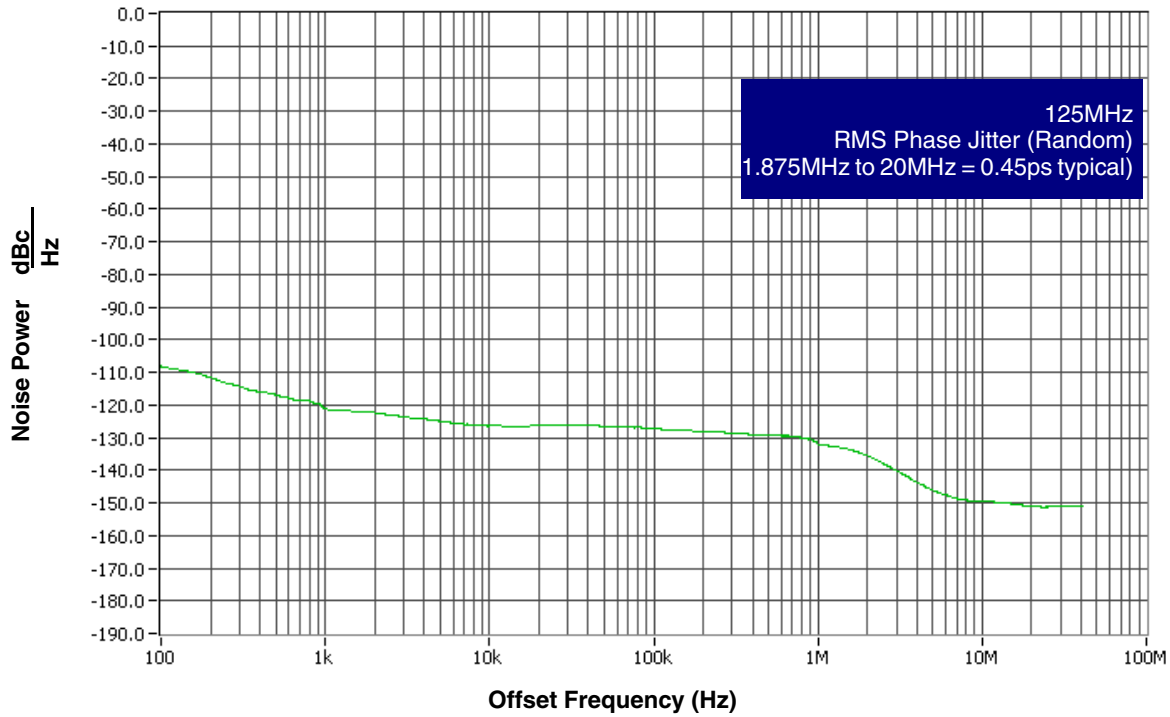

### Typical Phase Noise at 156.25MHz At 3.3V

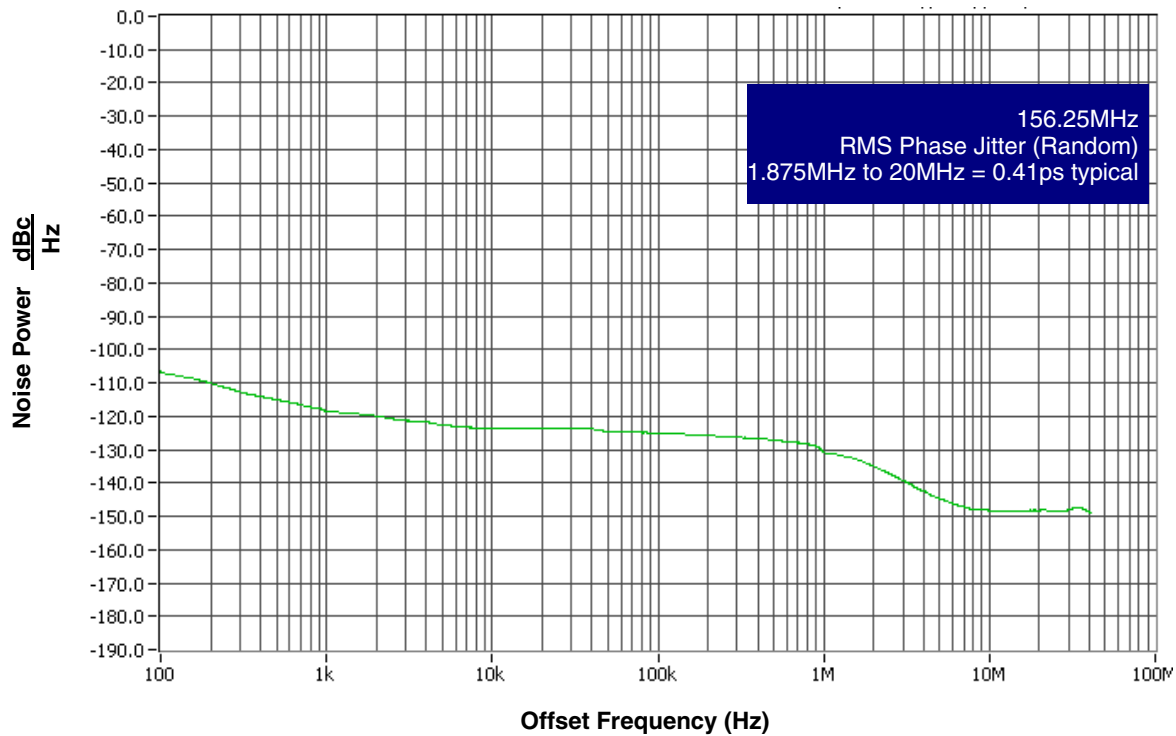

### Parameter Measurement Information

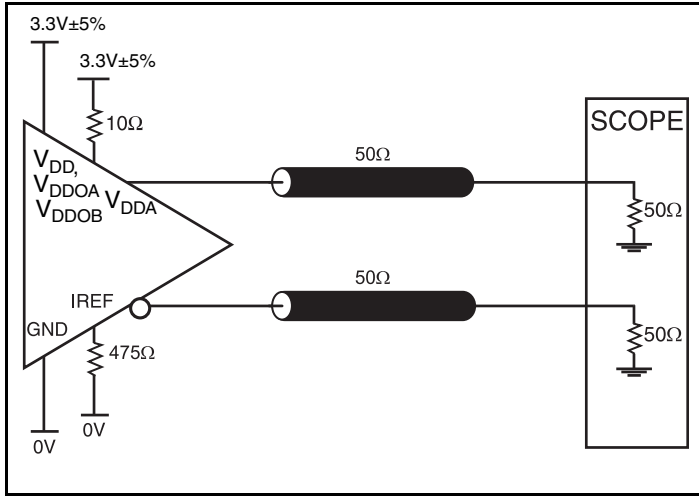

3.3V HCSL Output Load Test Circuit

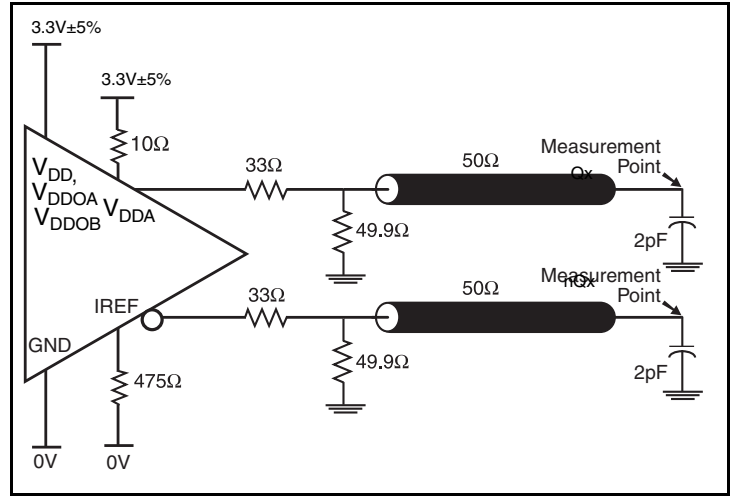

3.3V HCSL Output Load Test Circuit

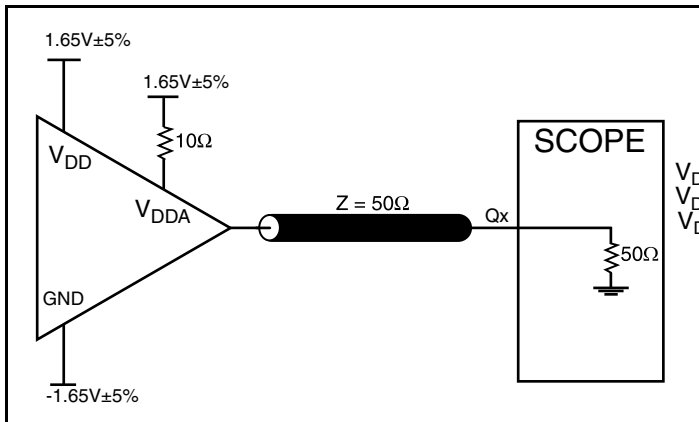

3.3V LVC MOS Output Load Test Circuit

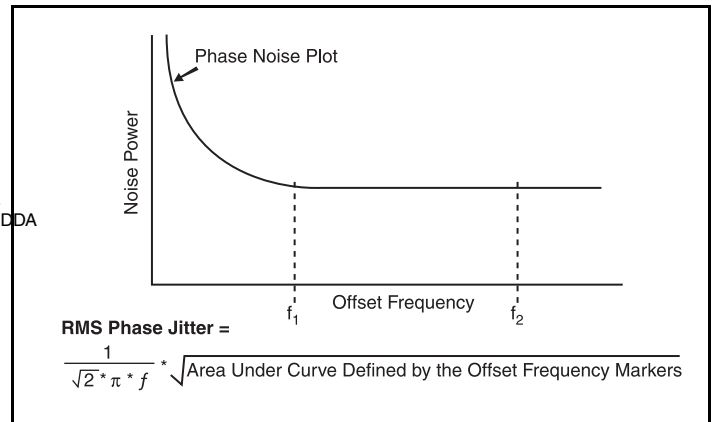

RMS Phase Jitter

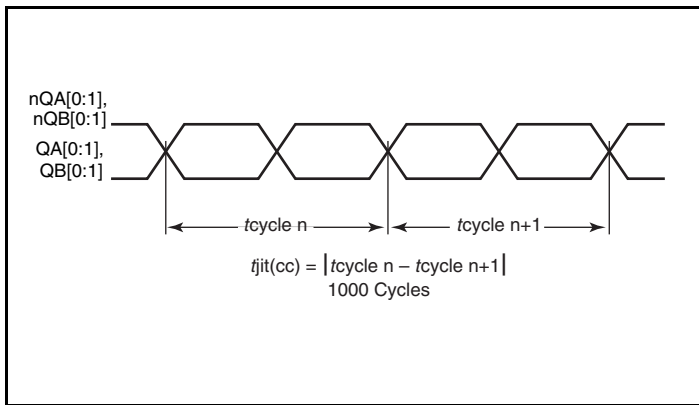

Cycle-to-Cycle Jitter

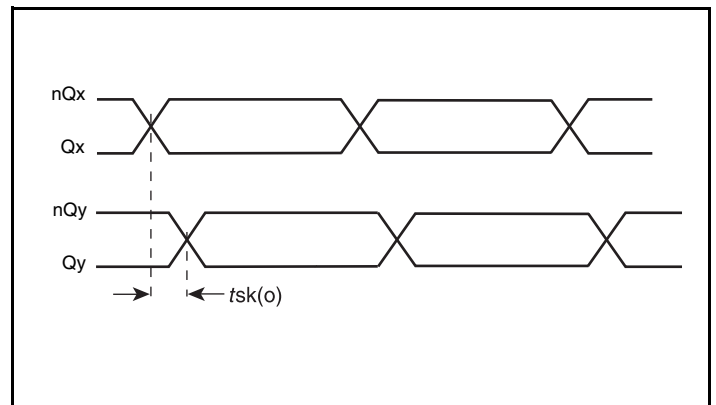

HCSL Output Skew



### Parameter Measurement Information, continued

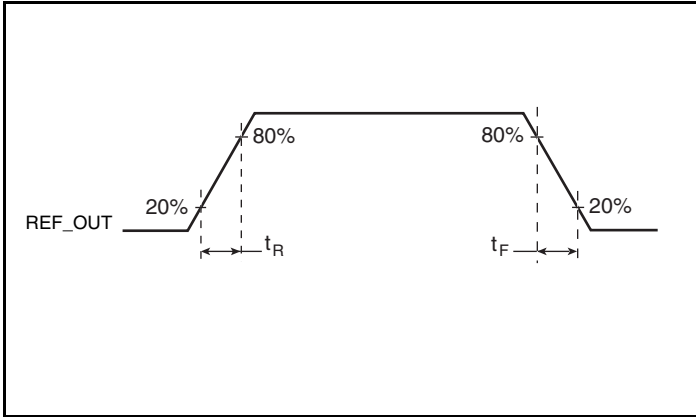

LVC MOS Output Rise/Fall Time

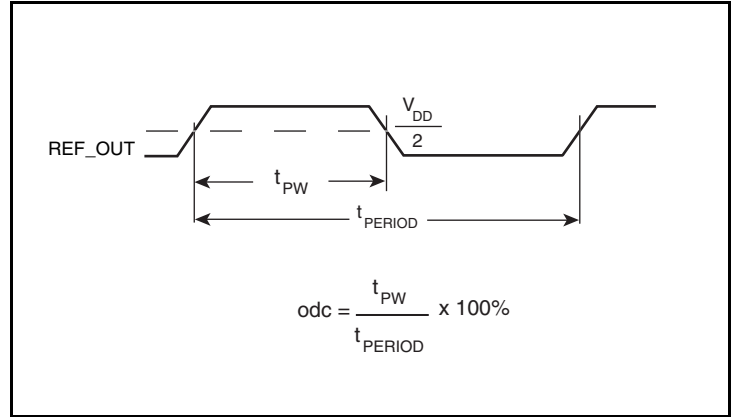

LVC MOS Output Duty Cycle/Pulse Width/Period

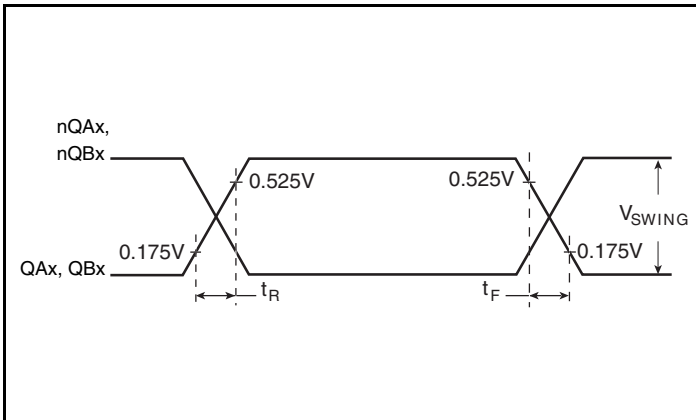

Differential Measurement Points For Rise/Fall Time

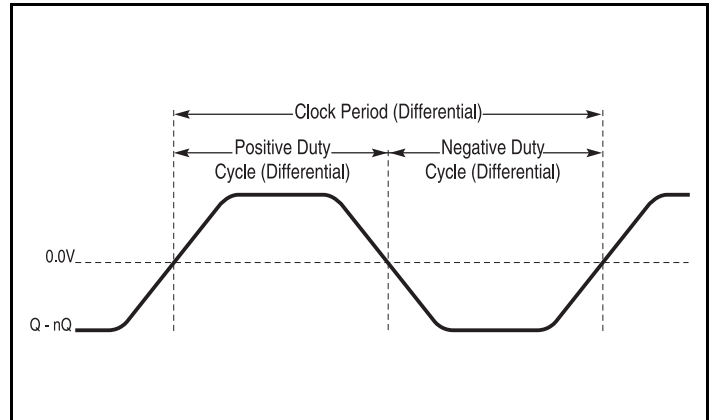

Differential Measurement Points For Duty Cycle/Period

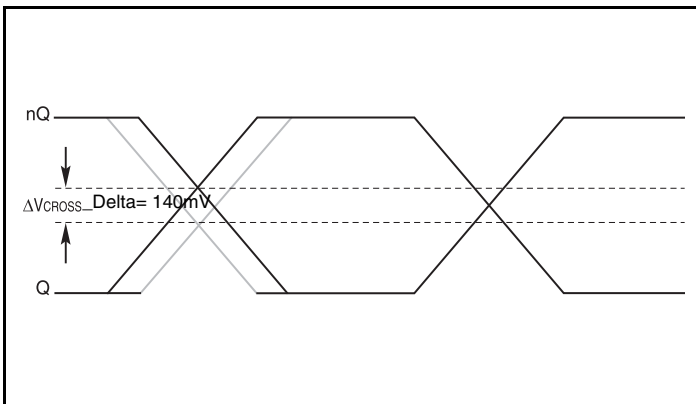

SE Measurement Points For Delta Cross Point

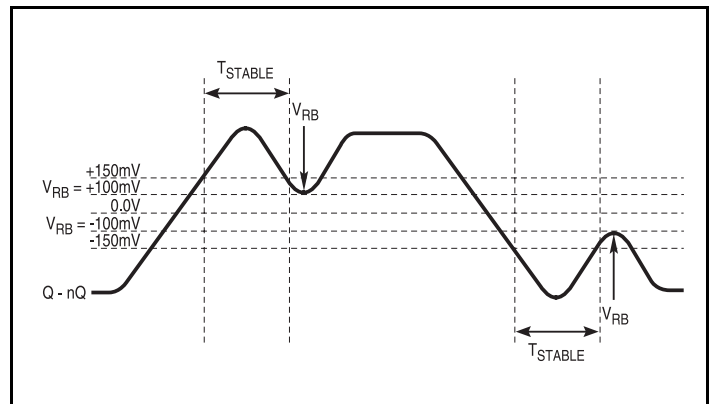

Differential Measurement Points For Ringback

## Parameter Measurement Information, continued

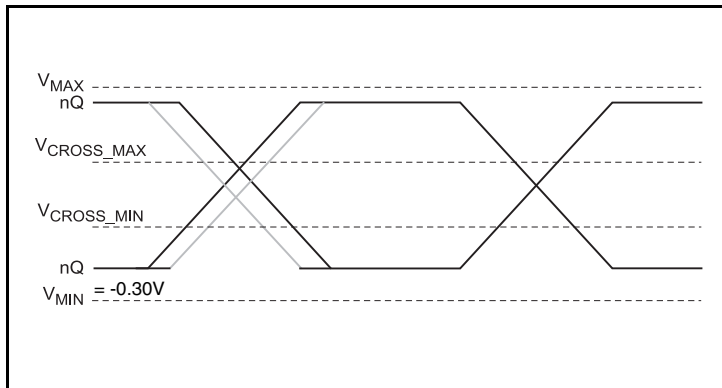

**SE Measurement Points For Absolute Cross Point/Swing**

## Applications Information

### Recommendations for Unused Input and Output Pins

#### Inputs:

##### Crystal Inputs

For applications not requiring the use of the crystal oscillator input, both XTAL\_IN and XTAL\_OUT can be left floating. Though not required, but for additional protection, a  $1k\Omega$  resistor can be tied from XTAL\_IN to ground.

##### REF\_CLK Input

For applications not requiring the use of the reference clock, it can be left floating. Though not required, but for additional protection, a  $1k\Omega$  resistor can be tied from the REF\_CLK to ground.

##### LVC MOS Control Pins

All control pins have internal pullups and pulldowns; additional resistance is not required but can be added for additional protection. A  $1k\Omega$  resistor can be used.

#### Outputs:

##### HCSL Outputs

All unused HCSL outputs can be left floating. We recommend that there is no trace attached. Both sides of the differential output pair should either be left floating or terminated.

##### LVC MOS Outputs

The unused LVC MOS output can be left floating. There should be no trace attached.

## Schematic Layout

Figure 1 shows an example of ICS841664I application schematic. In this example, the device is operated at  $V_{DD} = V_{DDA} = V_{DDOA} = V_{DDOB} = 3.3V$ . The 18pF parallel resonant 25MHz crystal is used. The load capacitance  $C1 = 27pF$  and  $C2 = 27pF$  are recommended for frequency accuracy. Depending on the parasitic of the printed circuit board layout, these values might require a slight adjustment to optimize the frequency accuracy. Crystals with other load capacitance specifications can be used. This will require

adjusting  $C1$  and  $C2$ . For this device, the crystal load capacitors are required for proper operation.

As with any high speed analog circuitry, the power supply pins are vulnerable to random noise. To achieve optimum jitter performance, power supply isolation is required. The ICS841664I provides separate power supplies to isolate any high switching noise from coupling into the internal PLL.

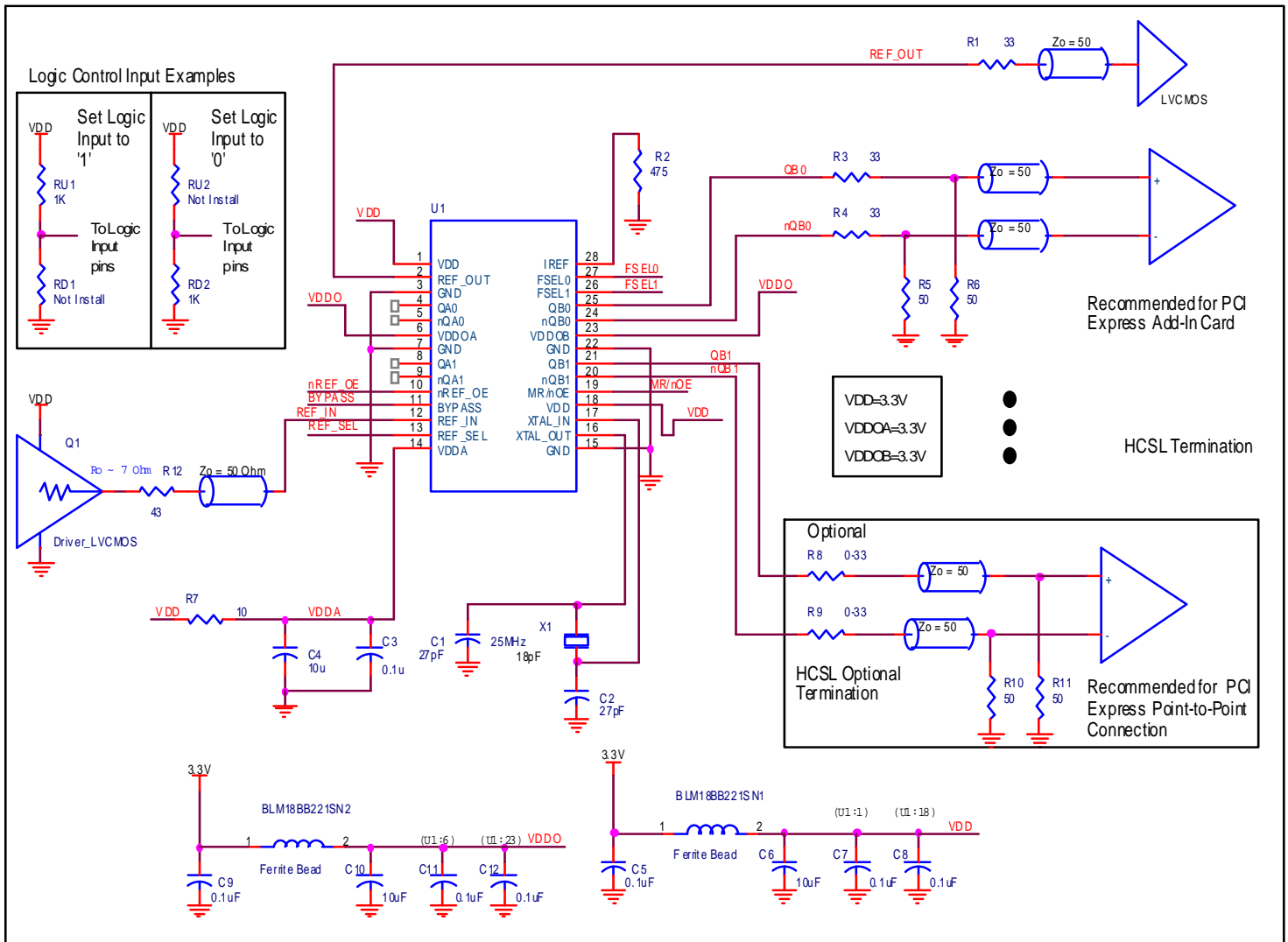

**Figure 1. ICS841664I Schematic Example**

In order to achieve the best possible filtering, it is recommended that the placement of the filter components be on the device side of the PCB as close to the power pins as possible. If space is limited, the 0.1µF capacitor in each power pin filter should be placed on the device side of the PCB and the other components can be placed on the opposite side.

Power supply filter recommendations are a general guideline to be used for reducing external noise from coupling into the devices. The filter performance is designed for wide range of noise frequency. This low-pass filter starts to attenuate noise at approximately 10kHz. If a specific frequency noise component with high amplitude interference

is known, such as switching power supplies frequencies, it is recommended that component values be adjusted and if required, additional filtering be added. Additionally general design practice for power plane voltage stability suggests adding bulk capacitances in the general area of all devices.

The schematic example focuses on functional connections and is not configuration specific. Refer to the pin description and functional tables in the datasheet to ensure the logic control inputs are properly set.

## Overdriving the XTAL Interface

The XTAL\_IN input can be overdriven by an LVCMOS driver or by one side of a differential driver through an AC coupling capacitor. The XTAL\_OUT pin can be left floating. The amplitude of the input signal should be between 500mV and 1.8V and the slew rate should not be less than 0.2V/nS. For 3.3V LVCMOS inputs, the amplitude must be reduced from full swing to at least half the swing in order to prevent signal interference with the power rail and to reduce internal noise. *Figure 2A* shows an example of the interface diagram for a high speed 3.3V LVCMOS driver. This configuration requires that the sum of the output impedance of the driver ( $R_o$ ) and the series resistance ( $R_s$ ) equals the transmission line impedance. In addition, matched termination at the crystal input will attenuate the signal in half. This

can be done in one of two ways. First,  $R_1$  and  $R_2$  in parallel should equal the transmission line impedance. For most 50Ω applications,  $R_1$  and  $R_2$  can be 100Ω. This can also be accomplished by removing  $R_1$  and changing  $R_2$  to 50Ω. The values of the resistors can be increased to reduce the loading for a slower and weaker LVCMOS driver. *Figure 2B* shows an example of the interface diagram for an LVPECL driver. This is a standard LVPECL termination with one side of the driver feeding the XTAL\_IN input. It is recommended that all components in the schematics be placed in the layout. Though some components might not be used, they can be utilized for debugging purposes. The datasheet specifications are characterized and guaranteed by using a quartz crystal as the input.

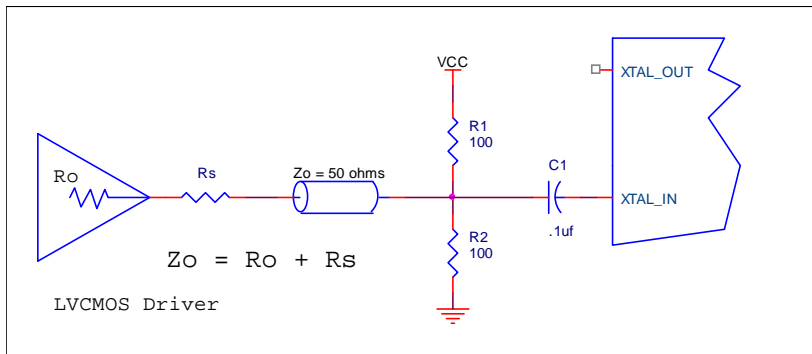

**Figure 2A. General Diagram for LVCMOS Driver to XTAL Input Interface**

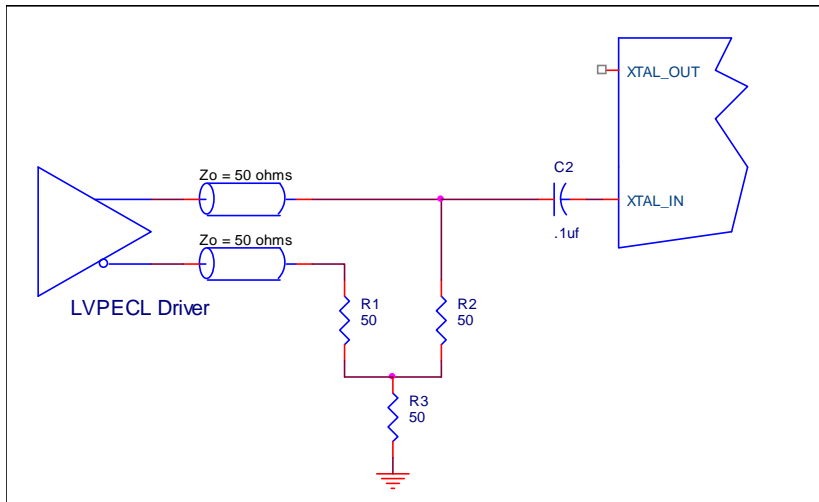

**Figure 2B. General Diagram for LVPECL Driver to XTAL Input Interface**

## Applications Information, continued

### Recommended Termination

Figure 3A is the recommended source termination for applications where the driver and receiver will be on a separate PCBs. This termination is the standard for PCI Express™ and HCSL output types.

All traces should be 50Ω impedance single-ended or 100Ω differential.

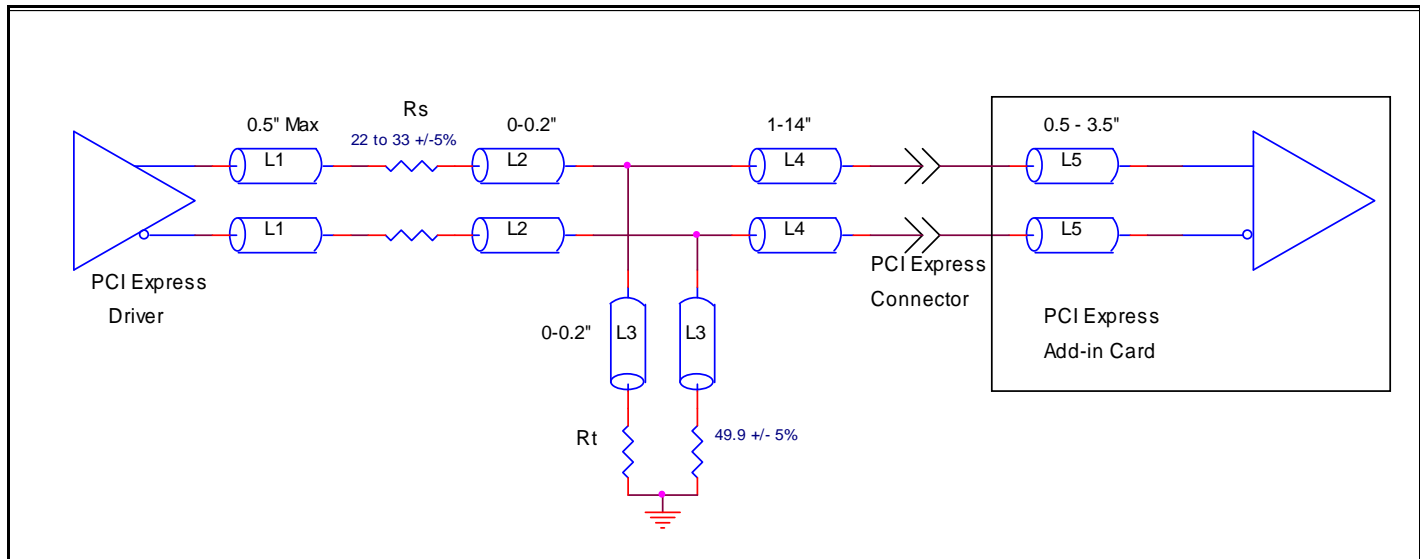

**Figure 3A. Recommended Source Termination (where the driver and receiver will be on separate PCBs)**

Figure 3B is the recommended termination for applications where a point-to-point connection can be used. A point-to-point connection contains both the driver and the receiver on the same PCB. With a matched termination at the receiver, transmission-line reflections will

be minimized. In addition, a series resistor ( $R_s$ ) at the driver offers flexibility and can help dampen unwanted reflections. The optional resistor can range from 0Ω to 33Ω. All traces should be 50Ω impedance single-ended or 100Ω differential.

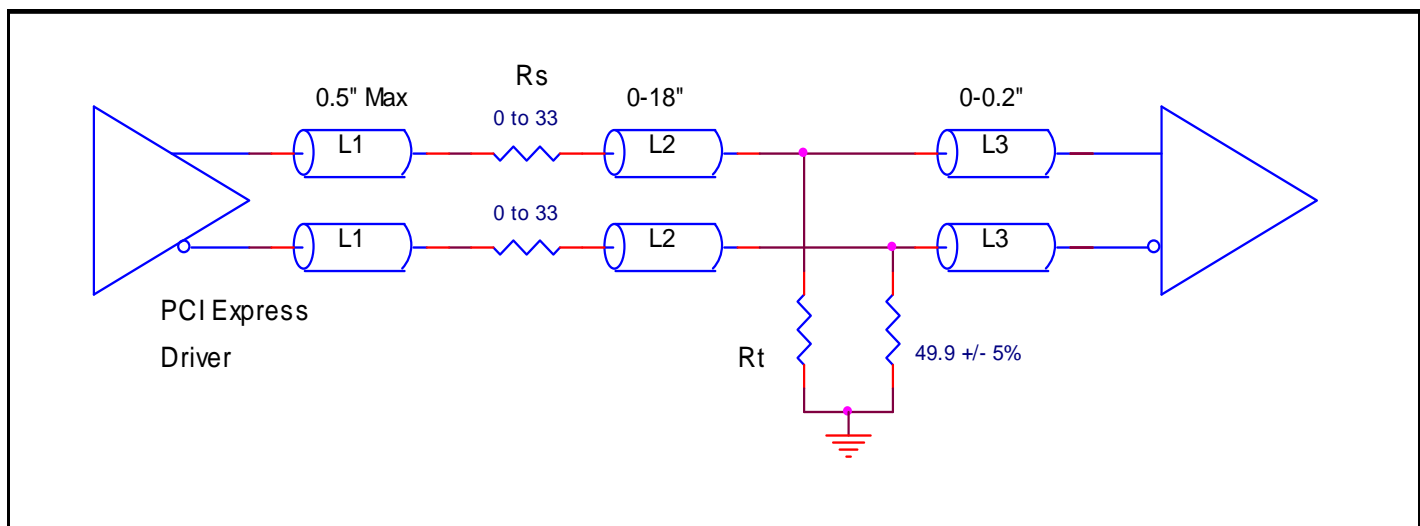

**Figure 3B. Recommended Termination (where a point-to-point connection can be used)**

## Power Considerations

This section provides information on power dissipation and junction temperature for the ICS841664I. Equations and example calculations are also provided.

### 1. Power Dissipation.

The total power dissipation for the ICS841664I is the total power minus the analog power plus the power dissipated into the load. The following is the power dissipation for  $V_{DD} = 3.3V + 5\% = 3.465V$ , which gives worst case results.

#### Core and HCSL Output Power Dissipation

- Power (core)<sub>MAX</sub> =  $V_{DD\_MAX} * (I_{DD\_MAX} + I_{DDA\_MAX}) = 3.465V * (80mA + 20mA) = \mathbf{346.5mW}$
- Power (outputs)<sub>MAX</sub> = **44.5mW/Loaded Output pair**  
If all outputs are loaded, the total power is  $4 * 44.5mW = \mathbf{178mW}$

#### LVC MOS Driver Power Dissipation

- Dynamic Power Dissipation at 25MHz  
Power (25MHz) =  $C_{PD} * \text{Frequency} * (V_{DD})^2 = 4pF * 25MHz * (3.465V)^2 = \mathbf{1.20mW \text{ per output}}$

#### Total Power Dissipation

- Total Power**  
= Power (core) + Power (Outputs) + Total Power (25MHz)  
=  $346.5mW + 178mW + 1.2mW$   
= **525.7mW**

### 2. Junction Temperature.

Junction temperature,  $T_j$ , is the temperature at the junction of the bond wire and bond pad directly affects the reliability of the device. The maximum recommended junction temperature is 125°C. Limiting the internal transistor junction temperature,  $T_j$ , to 125°C ensures that the bond wire and bond pad temperature remains below 125°C.

The equation for  $T_j$  is as follows:  $T_j = \theta_{JA} * Pd\_total + T_A$

$T_j$  = Junction Temperature

$\theta_{JA}$  = Junction-to-Ambient Thermal Resistance

$Pd\_total$  = Total Device Power Dissipation (example calculation is in section 1 above)

$T_A$  = Ambient Temperature

In order to calculate junction temperature, the appropriate junction-to-ambient thermal resistance  $\theta_{JA}$  must be used. Assuming no air flow and a multi-layer board, the appropriate value is 64.5°C/W per Table 7 below.

Therefore,  $T_j$  for an ambient temperature of 85°C with all outputs switching is:

$$85^\circ\text{C} + 0.526W * 64.3^\circ\text{C/W} = 118.9^\circ\text{C}. \text{ This is below the limit of } 125^\circ\text{C}.$$

This calculation is only an example.  $T_j$  will obviously vary depending on the number of loaded outputs, supply voltage, air flow and the type of board (multi-layer).

**Table 7. Thermal Resistance  $\theta_{JA}$  for 28 Lead TSSOP, Forced Convection**

Meters per Second	$\theta_{JA}$ by Velocity		
	0	1	2.5
Multi-Layer PCB, JEDEC Standard Test Boards	64.5°C/W	60.4°C/W	58.5°C/W

### 3. Calculations and Equations.

The purpose of this section is to calculate power dissipation on the IC per HCSL output pair.

HCSL output driver circuit and termination are shown in *Figure 4*.

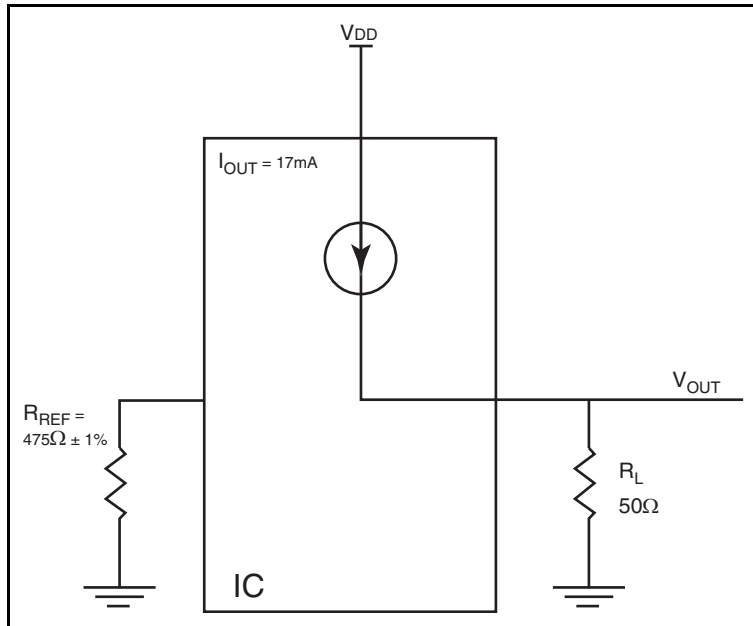

**Figure 4. HCSL Driver Circuit and Termination**

HCSL is a current steering output which sources a maximum of 17mA of current per output. To calculate worst case on-chip power dissipation, use the following equations which assume a  $50\Omega$  load to ground.

The highest power dissipation occurs when  $V_{DD\_MAX}$ .

$$\text{Power} = (V_{DD\_MAX} - V_{OUT}) * I_{OUT}$$

$$\text{since } V_{OUT} = I_{OUT} * R_L$$

$$\text{Power} = (V_{DD\_MAX} - I_{OUT} * R_L) * I_{OUT}$$

$$= (3.465\text{V} - 17\text{mA} * 50\Omega) * 17\text{mA}$$

Total Power Dissipation per output pair = **44.5mW**

## Reliability Information

Table 8.  $\theta_{JA}$  vs. Air Flow Table for a 28 Lead TSSOP

$\theta_{JA}$ by Velocity			
Meters per Second	0	1	2.5
Multi-Layer PCB, JEDEC Standard Test Boards	64.5°C/W	60.4°C/W	58.5°C/W

## Transistor Count

The transistor count for ICS841664I is: 2954

## Package Outline and Package Dimensions

Package Outline - G Suffix for 28 Lead TSSOP

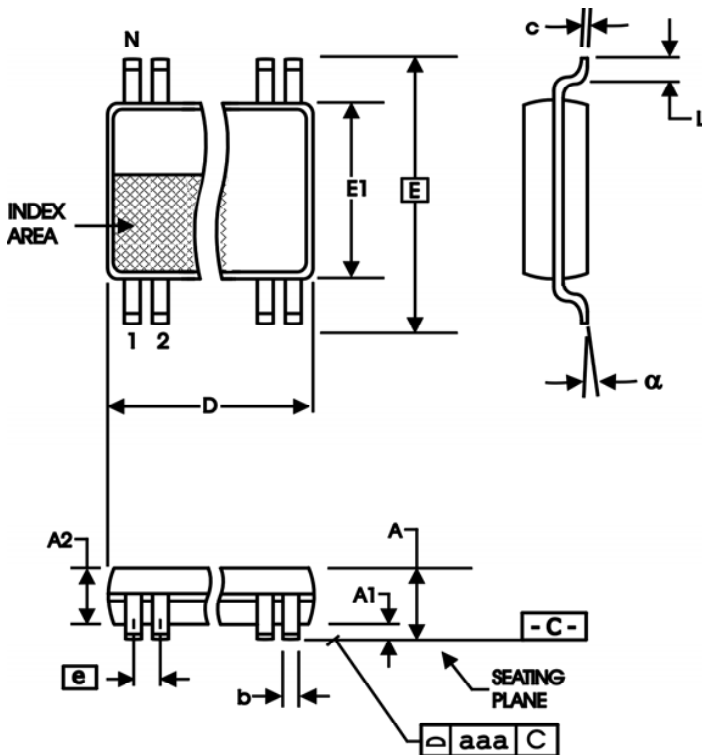

Table 9. Package Dimensions

All Dimensions in Millimeters		
Symbol	Minimum	Maximum
N	28	
A		1.20
A1	0.05	0.15
A2	0.80	1.05
b	0.19	0.30
c	0.09	0.20
D	9.60	9.80
E	8.10 Basic	
E1	6.00	6.20
e	0.65 Basic	
L	0.45	0.75
$\alpha$	0°	8°
aaa		0.10

Reference Document: JEDEC Publication 95, MO-153



## Ordering Information

**Table 10. Ordering Information**

<b>Part/Order Number</b>	<b>Marking</b>	<b>Package</b>	<b>Shipping Packaging</b>	<b>Temperature</b>
841664AGILF	ICS841664AGI	28 Lead "Lead-Free" TSSOP	Tube	-40°C to 85°C
841664AGILFT	ICS841664AGI	28 Lead "Lead-Free" TSSOP	Tape & Reel	-40°C to 85°C

## Revision History Sheet

Rev	Table	Page	Description of Change	Date
A	T1 T10	2 18	Pin Description Table - switched pin names for pins 20 through 25. Ordering Information Table - deleted Tape & Reel quantity.	7/15/13

## We've Got Your Timing Solution



6024 Silver Creek Valley Road  
San Jose, California 95138

**Sales**  
800-345-7015 (inside USA)  
+408-284-8200 (outside USA)  
Fax: 408-284-2775  
[www.IDT.com/go/contactIDT](http://www.IDT.com/go/contactIDT)

**Technical Support Sales**  
[netcom@idt.com](mailto:netcom@idt.com)  
+480-763-2056

DISCLAIMER Integrated Device Technology, Inc. (IDT) and its subsidiaries reserve the right to modify the products and/or specifications described herein at any time and at IDT's sole discretion. All information in this document, including descriptions of product features and performance, is subject to change without notice. Performance specifications and the operating parameters of the described products are determined in the independent state and are not guaranteed to perform the same way when installed in customer products. The information contained herein is provided without representation or warranty of any kind, whether express or implied, including, but not limited to, the suitability of IDT's products for any particular purpose, an implied warranty of merchantability, or non-infringement of the intellectual property rights of others. This document is presented only as a guide and does not convey any license under intellectual property rights of IDT or any third parties.

IDT's products are not intended for use in applications involving extreme environmental conditions or in life support systems or similar devices where the failure or malfunction of an IDT product can be reasonably expected to significantly affect the health or safety of users. Anyone using an IDT product in such a manner does so at their own risk, absent an express, written agreement by IDT.

Integrated Device Technology, IDT and the IDT logo are registered trademarks of IDT. Other trademarks and service marks used herein, including protected names, logos and designs, are the property of IDT or their respective third party owners.

# Mouser Electronics

Authorized Distributor

Click to View Pricing, Inventory, Delivery & Lifecycle Information:

[IDT \(Integrated Device Technology\):](#)

[841664AGILF](#) [841664AGILFT](#)