

DO NOT SCALE FROM THIS PRINT

NOTES:

1.  $\text{C}$  REPRESENTS A CRITICAL DIMENSION.
2. MINIMUM PUSHOUT FORCE SHALL BE 1 LB.
3. GOLD AREA TO APPEAR ON POST.
4. TAILS TO BE SHEARED TO DIMENSION SHOWN. (FOR HAND TOOLING ONLY)
5. TO BE VALID ALL PART NUMBERS MUST MEET THE FOLLOWING PARAMETERS: THE BOARD SPACE RANGE, POST HEIGHT MIN. AND BOARD + POST COMBINATION FOR EACH STYLE.
6. MAXIMUM BURR: .003[0.08] ON CUT TAIL.
7. MAXIMUM CUT FLASH TO BE .010[0.25] ON CRITICAL AREAS AS SHOWN.
8. AVAILABLE ONLY W/BOARD SPACE .215[5.46] TOP .610[15.49].
9. PARTS TO BE ASSEMBLED WITH ALIGNMENT HOLES (IN BODY) FACING THE TAILS
10. LOWER BODY MAY BE BLACK OR WHITE.
11. FILL BODY SO THAT THE LEAD IN OF THE CORE IS ON THE TAIL SIDE.
12. MAXIMUM HEIGHT VARIATION BETWEEN ROWS: .005[0.13].
13. FOR ADDED MECHANICAL STABILITY, SAMTEC RECOMMENDS MECHANICAL BOARD SPACERS BE USED IN APPLICATIONS WITH GOLD OR SELECTIVE GOLD PLATED CONNECTORS. CONTACT IPG@SAMTEC.COM FOR MORE INFORMATION.
14. SUB-FW-50-03-XX-D-280-015 TO USE T-1S15-08, SUB-FW-50-05-XX-D-400-065 TO USE T-1S15-03.

PATENT NUMBERS  
5713755 / 5961339

FW-XX-XX-XX-D-XXX-XXX-XX

POSITION SPEC  
No. OF POS PER ROW  
-02 THRU -50

LEAD STYLE  
-03: USE T-1S15-XX-X  
-05: USE T-1S15-XX-X  
(SEE TABLE 1)

PLATING  
-G: 10 $\mu$ " GOLD IN CONTACT AREA,  
3 $\mu$ " GOLD ON TAIL  
-F: 3 $\mu$ " SELECTIVE GOLD IN CONTACT AREA,  
MATTE TIN ON TAIL  
-L: 10 $\mu$ " SELECTIVE GOLD IN CONTACT AREA,  
MATTE TIN TAIL  
-H: 30 $\mu$ " GOLD IN CONTACT AREA,  
3 $\mu$ " GOLD ON TAIL  
-LM: 10 $\mu$ " SELECTIVE GOLD IN CONTACT AREA,  
MATTE TIN TAIL  
-FM: 3 $\mu$ " SELECTIVE GOLD IN CONTACT AREA,  
MATTE TIN ON TAIL  
-S: 30 $\mu$ " SELECTIVE GOLD IN CONTACT AREA,  
MATTE TIN ON TAIL

OPTION

- P: PICK & PLACE PAD (USE PPP-25)  
(USE PPP-25-NT WITH -TR ONLY)  
(SEE FIG. 3, SHT 2)(5 POS. MIN)
- TR: TAPE & REEL  
.740[18.80] MAX OVERALL HEIGHT AVAILABLE FOR  
-TR. MAX OVERALL HEIGHT = POST + BOARDSPACE  
+ PAD + ALIGNMENT PIN = .740[18.80]
- ES: END SHROUDS (SEE FIG. 5, SHT 2)  
(9 POS PER ROW MIN)  
(MAX POST: .075[1.91])  
(SEE NOTE 8)
- EP: GUIDE POST (FIG. 6, SHT 3)  
(9 POS PER ROW MIN)  
(MAX POST: .075[1.91])  
(USE ONLY WHEN MATING WITH CLP)  
(SEE NOTE 8)
- A: ALIGNMENT PIN (MOLDED OR STAKED, SAMTEC'S  
DISCRETION ON WHICH)  
(SEE FIG. 7 & 8 SHT 3)  
(STAKED: 6 POS. MIN)(MOLDED: 3 POS. MIN)  
(SEE NOTE 8)

POST HEIGHT (SEE NOTE 5)  
.065[1.65] MIN  
POST + BOARD SPACE = "F" =  
-03: .150-.400 [3.81-10.16]  
.401-.675 [10.19-17.15]  
-05: .150-.400 [3.81-10.16]  
.401-.675 [10.19-17.15]

BOARD SPACE OPTION (SEE NOTE 5)  
SEE TABLE 1  
-03 LEAD STYLE (.085[2.16] MIN - .335[8.51] MAX)  
-05 LEAD STYLE (.248[6.30] MIN - .610[15.49] MAX)  
MAX = "A" - POST (SEE TABLE 1)

\* = FOR EXISTING CUSTOMERS ONLY

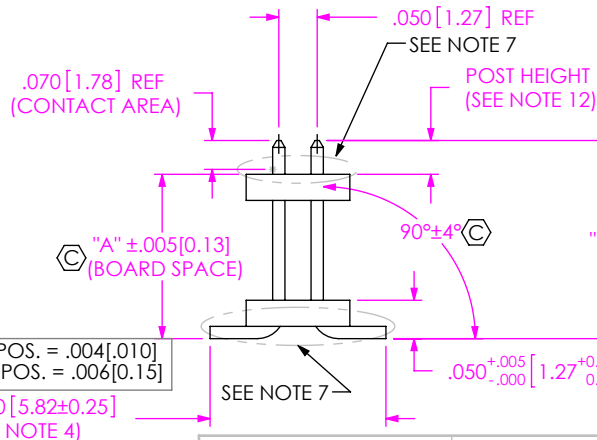
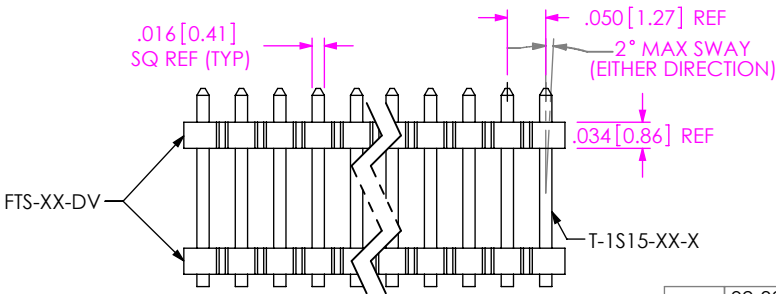
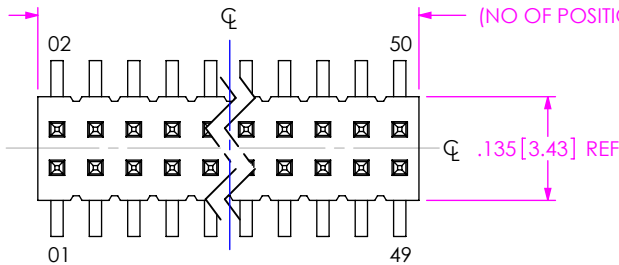

$\text{C}$  02-30 POS. = .004[0.10]  
31-50 POS. = .006[0.15]  
 $\text{C}$  .229±.010 [5.82±0.25]  
(SEE NOTE 4)

LEAD STYLE	OPTIONS	OVERALL HEIGHT	PACKAGING TUBE	PLUG
-03	-A-P	.150 - .650	PT-FW005-D-03-P	TP-03
-03	NONE, A	.150 - .225	PT-FW005-D-03-P	TP-03
-03	NONE, A	.226 - .309	PT-FW005-D-03-P	TP-03
-03	NONE, A	.310 - .400	PT-FW005-D-03-P	TP-03
-05	NONE, A	.310 - .800	PT-FW006-D-05-P	TP-03
-05	-A-P	.310 - .650	PT-FW006-D-05-P	TP-03
-05	-A-P	.651 - .800	PT-FW006-D-05-P	TP-03
-03, -05	-ES, -EP, -ES-A, -ES-A-P, -ES-P, -EP-A, -EP-P, -EP-A-P	ALL	PT-1-24-01-71	TP-03

PACKAGING NOTE:  
TUBE POSITIONS 5-50, LAYER PACKAGE ALL OTHERS

LEAD STYLE	"F" RANGE	TERMINAL PIN
-03	.150-.299	T-1S15-04-X
-03	.300-.400	T-1S15-03-X
-05	.401-.675	T-1S15-03-X

(SEE NOTE 14)

FIG 1

LEAD STYLE	"A" RANGE	"C" RANGE (SEE SHEET 2, FIG 5 & 6)	"D" RANGE (SEE SHEET 2, FIG 5 & 6)	BODY STYLE		FIG
				UPPER BODY	LOWER BODY	
-03	.085 - .214 [2.16 - 5.44]	N/A	N/A	FTS-XX-DV	FTS-XX-DV	1
-03	.215 - .335 [5.46 - 8.51]	.293 - .423 REF [7.45 - 10.75]	.413 - .543 REF [10.50 - 13.79]	FTSH-XX-D	*FTSH-XX-D	2 (SEE SHEET 2)
-05	.248 - .610 [6.30 - 15.49]	.326 - .698 REF [8.28 - 17.73]	.446 - .818 REF [11.32 - 20.78]	FTSH-XX-D	FTSH-XX-D	4 (SEE SHEET 2)

\* FOR BKT MACHINE, USE FW-XX-D

UNLESS OTHERWISE SPECIFIED, DIMENSIONS ARE IN INCHES.

TOLERANCES ARE:  
DECIMALS ANGLES  
.XX: ±.01[0.3]  
.XXX: ±.005[0.13]  
.XXXX: ±.0020[0.051]

PROPRIETARY NOTE  
THIS DOCUMENT CONTAINS CONFIDENTIAL AND PROPRIETARY INFORMATION AND ALL DESIGN, MANUFACTURING, REPRODUCTION, USE, PATENT RIGHTS AND SALES RIGHTS ARE EXPRESSLY RESERVED BY SAMTEC, INC. THIS DOCUMENT SHALL NOT BE DISCLOSED, IN WHOLE OR PART, TO ANY UNAUTHORIZED PERSON OR ENTITY NOR REPRODUCED, TRANSFERRED OR INCORPORATED IN ANY OTHER PROJECT IN ANY MANNER WITHOUT THE EXPRESS WRITTEN CONSENT OF SAMTEC, INC.

MATERIAL: DO NOT SCALE DRAWING SHEET SCALE: 4:1  
BODY: LCP, UL 94 VO, COLOR: FTS-50-DV & FTSH-50-D: BLACK  
FW-50-D: NATURAL

TERMINAL: PHOS BRONZE  
MAX FLASH ALLOWED: .002[0.05]  
MAX GATE VESTIGE: .002[0.05]

F:\DWG\MISC\MKTG\FW-XX-XX-XX-D-XXX-XXX-XX-MKT.SLDDRW



520 PARK EAST BLVD, NEW ALBANY, IN 47150  
PHONE: 812-944-6733 FAX: 812-948-5047  
e-Mail: info@SAMTEC.com code 53322

DESCRIPTION:  
.050 X .050 SURFACE MOUNT BOARD SPACERS

DWG. NO.  
FW-XX-XX-XX-D-XXX-XXX-XX

BY: BRATCHER 11-03-1994 SHEET 1 OF 4

IN-PROCESS 1

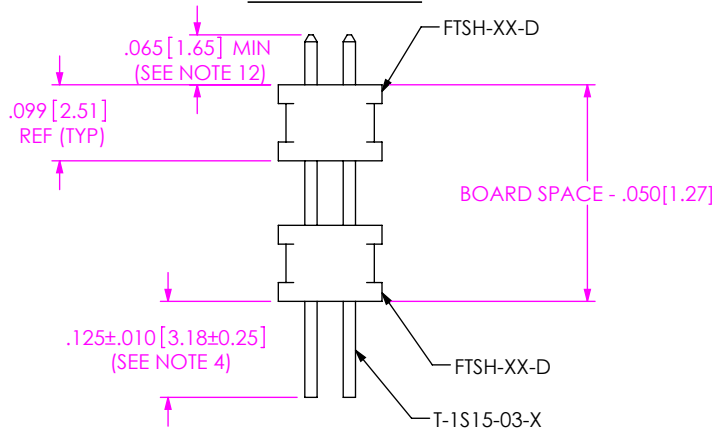

NOTE: SHEAR TAILS TO DIM SHOWN.

IN-PROCESS 2

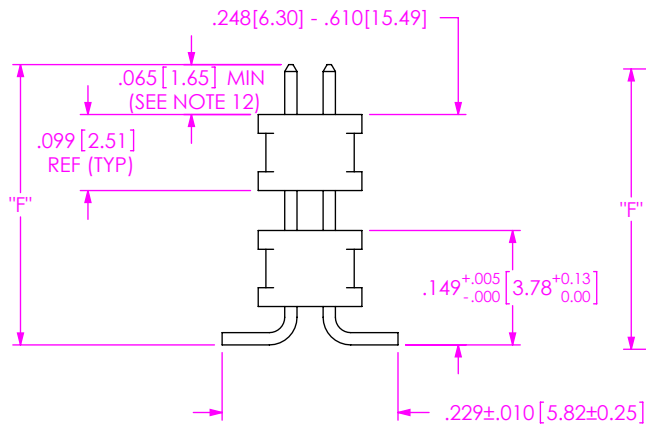

IN-PROCESS 3

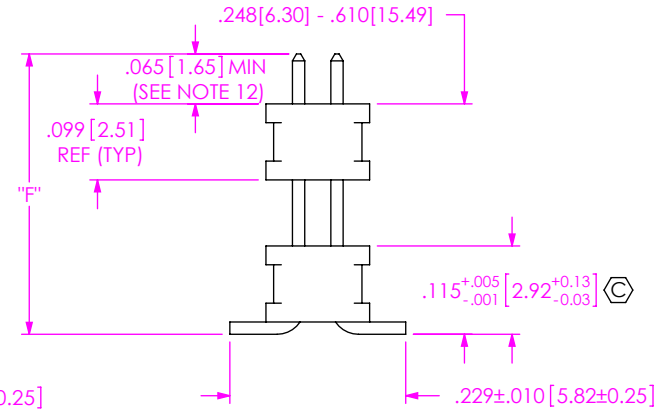

FIG 4

DIFFERENT AS SHOWN, OTHERWISE THE SAME AS FIG 1

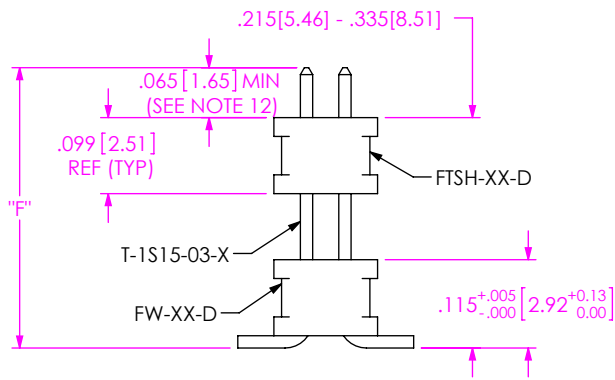

FIG 2  
(BKT MACHINE)

DIFFERENT AS SHOWN, OTHERWISE THE SAME AS FIG 1

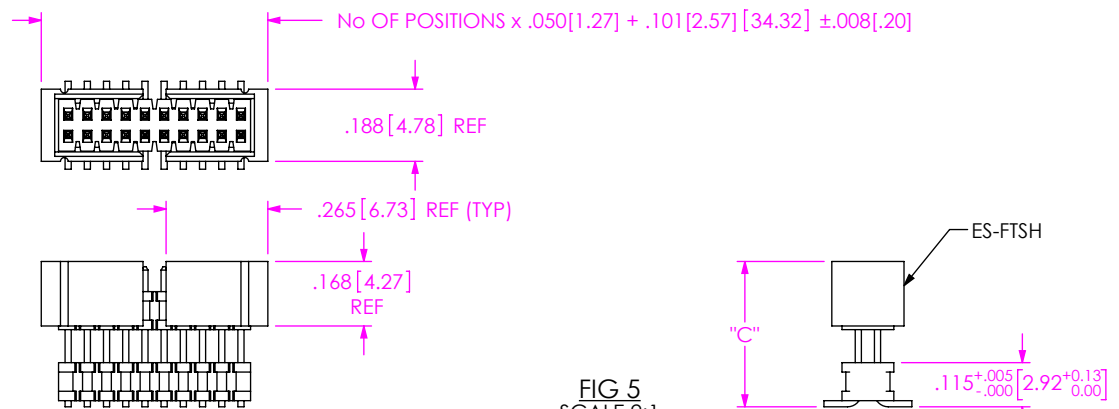

FIG 5  
SCALE 2:1  
-ES OPTION

DIFFERENT AS SHOWN, OTHERWISE THE SAME AS FIG 1  
9 POSITION MINIMUM (SEE NOTE 8)

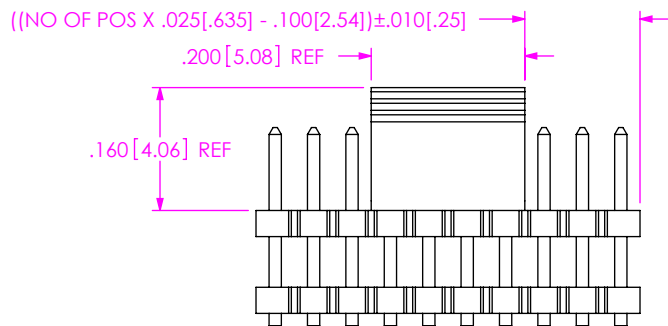
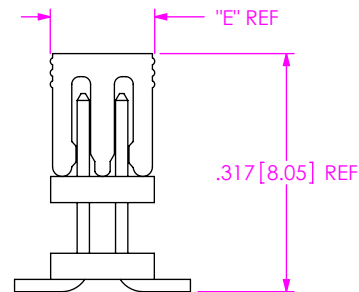

FIG 3  
(PICK AND PLACE PAD)  
(5 POSITION MINIMUM)



SHOWN WITH LEAD STYLE -03

F:\DWG\MISC\MKTG\FW-XX-XX-XX-D-XXX-XXX-XX-MKT.SLDDRW

PROPRIETARY NOTE

THIS DOCUMENT CONTAINS CONFIDENTIAL AND PROPRIETARY INFORMATION AND ALL DESIGN, MANUFACTURING, REPRODUCTION, USE, PATENT RIGHTS AND SALES RIGHTS ARE EXPRESSLY RESERVED BY SAMTEC, INC. THIS DOCUMENT SHALL NOT BE DISCLOSED, IN WHOLE OR PART, TO ANY UNAUTHORIZED PERSON OR ENTITY NOR REPRODUCED, TRANSFERRED OR INCORPORATED IN ANY OTHER PROJECT IN ANY MANNER WITHOUT THE EXPRESS WRITTEN CONSENT OF SAMTEC, INC.

DO NOT SCALE DRAWING

SHEET SCALE: 4:1



520 PARK EAST BLVD, NEW ALBANY, IN 47150  
PHONE: 812-944-6733 FAX: 812-948-5047  
e-Mail info@SAMTEC.com code 55322

DESCRIPTION:  
.050 x .050 SURFACE MOUNT BOARD SPACERS

DWG. NO.  
FW-XX-XX-XX-D-XXX-XXX-XX

BY: BRATCHER 11-03-1994 SHEET 2 OF 4

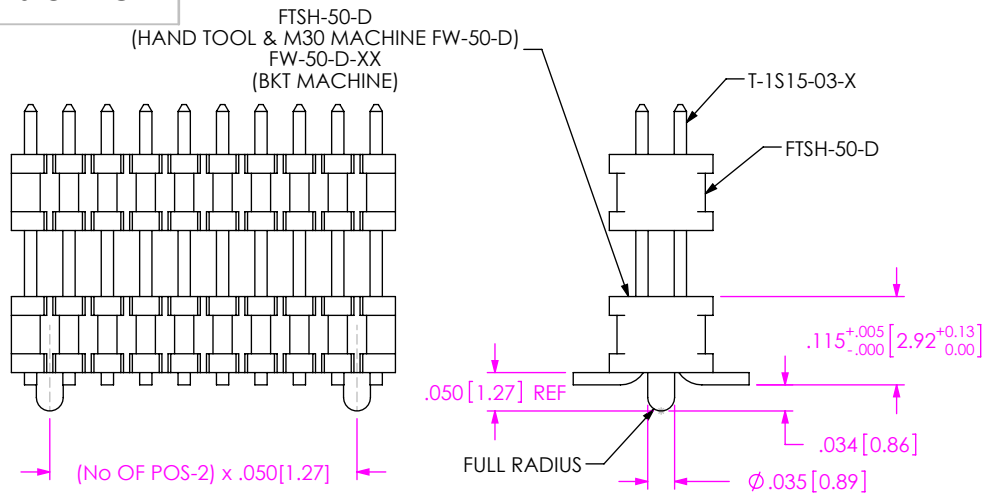

**FIG 7**  
-A OPTION (MOLDED)  
MOLD 3 POSITION MIN  
DIFFERENT AS SHOWN OTHERWISE SAME AS FIG 1

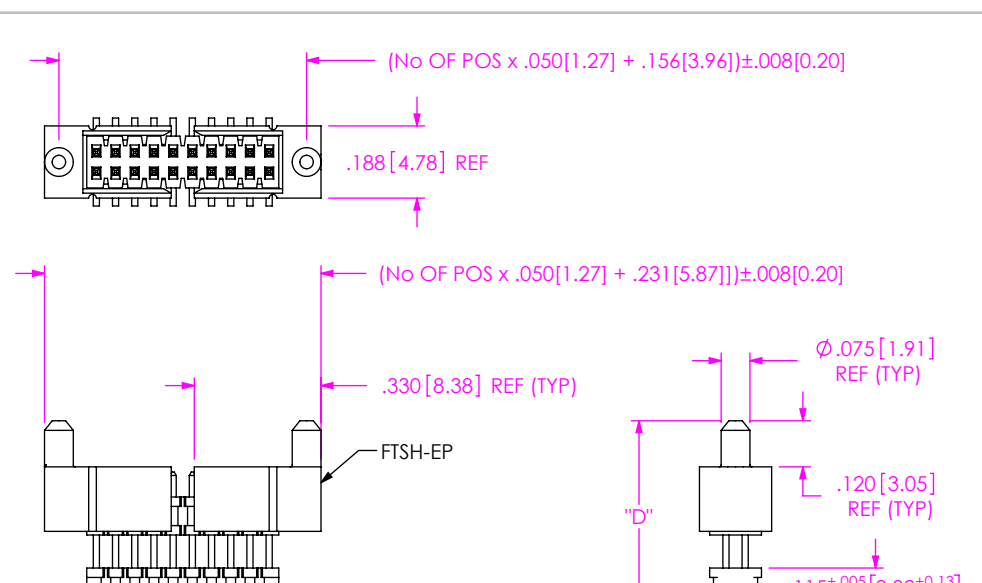
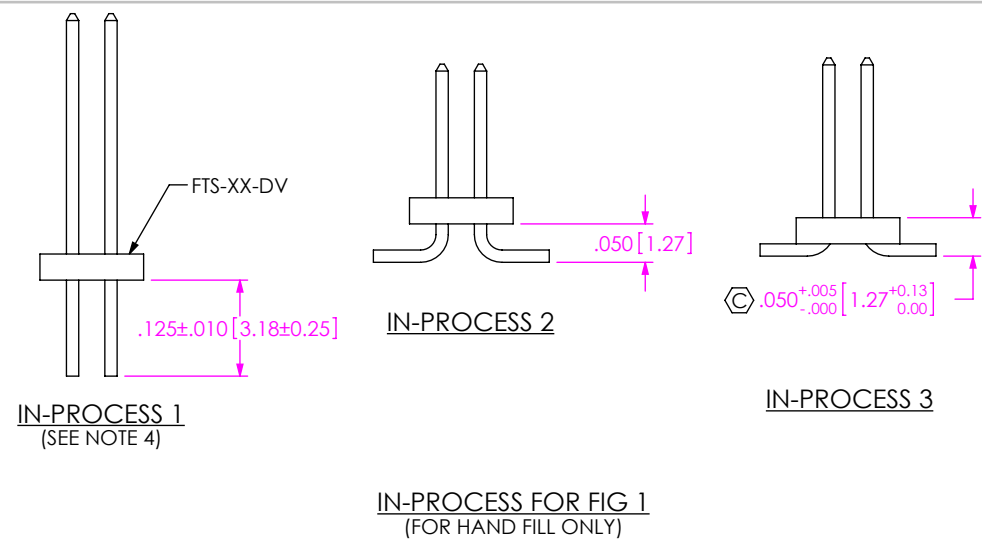

**FIG 6**  
-EP OPTION  
USE ONLY WHEN MATING TO CLP  
(9 POSITION MIN)  
(SEE NOTE 8)  
DIFFERENT AS SHOWN, OTHERWISE SAME AS FIG 1

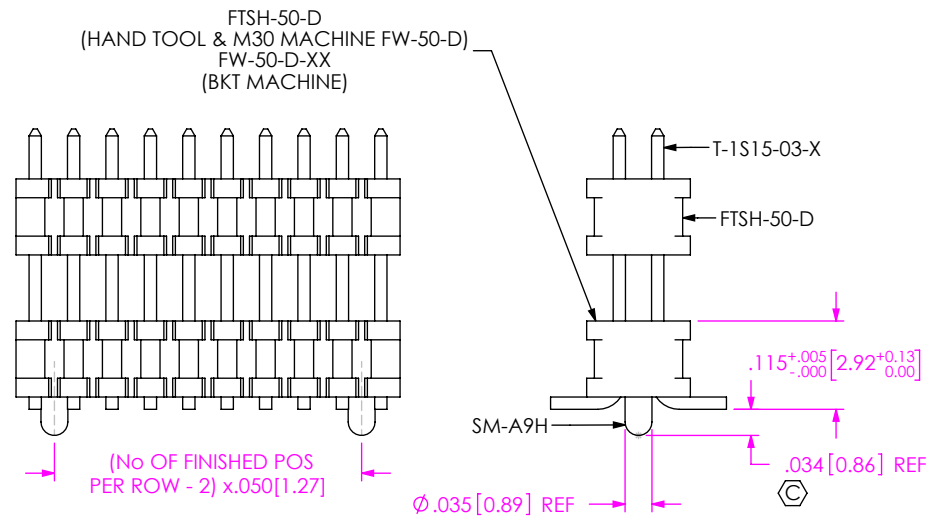

**FIG 8**  
-A OPTION (STAKED)  
6 POSITION MIN  
DIFFERENT AS SHOWN OTHERWISE SAME AS FIG 1

**PROPRIETARY NOTE**  
THIS DOCUMENT CONTAINS CONFIDENTIAL AND PROPRIETARY INFORMATION AND ALL DESIGN, MANUFACTURING, REPRODUCTION, USE, PATENT RIGHTS AND SALES RIGHTS ARE EXPRESSLY RESERVED BY SAMTEC, INC. THIS DOCUMENT SHALL NOT BE DISCLOSED, IN WHOLE OR PART, TO ANY UNAUTHORIZED PERSON OR ENTITY NOR REPRODUCED, TRANSFERRED OR INCORPORATED IN ANY OTHER PROJECT IN ANY MANNER WITHOUT THE EXPRESS WRITTEN CONSENT OF SAMTEC, INC.  
DO NOT SCALE DRAWING  
SHEET SCALE: 4:1

**samtec**  
520 PARK EAST BLVD, NEW ALBANY, IN 47150  
PHONE: 812-944-6733 FAX: 812-948-5047  
e-Mail info@SAMTEC.com code 55322

DESCRIPTION:  
.050 x .050 SURFACE MOUNT BOARD SPACERS  
DWG. NO.  
**FW-XX-XX-XX-D-XXX-XXX-XX**  
BY: BRATCHER 11-03-1994 SHEET 3 OF 4

IN-PROCESS 1

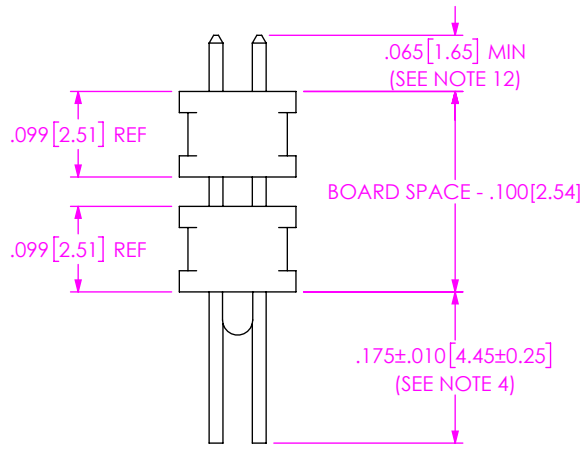

NOTE: SHEAR TAILS TO DIM SHOWN.

IN-PROCESS 2

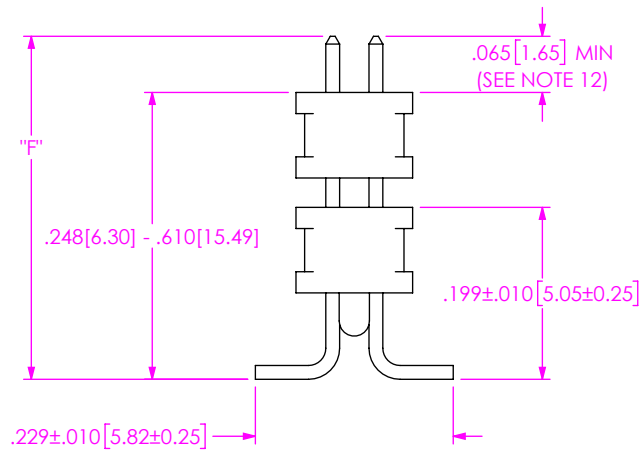

IN-PROCESS 3

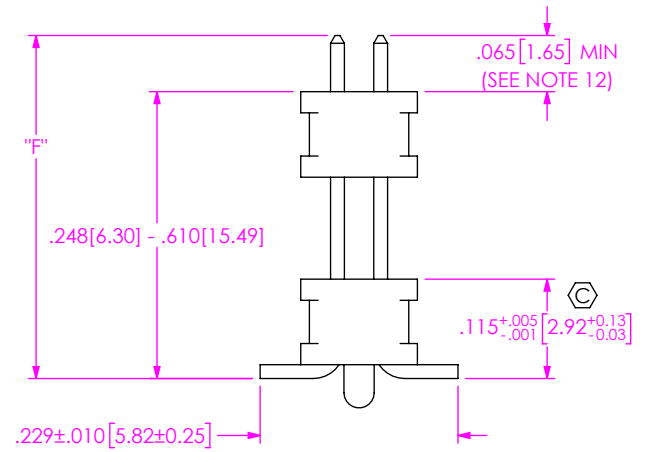

IN-PROCESS FOR -A OPTION  
(FOR HAND FILL ONLY)

**PROPRIETARY NOTE**  
THIS DOCUMENT CONTAINS CONFIDENTIAL AND PROPRIETARY INFORMATION AND ALL DESIGN, MANUFACTURING, REPRODUCTION, USE, PATENT RIGHTS AND SALES RIGHTS ARE EXPRESSLY RESERVED BY SAMTEC, INC. THIS DOCUMENT SHALL NOT BE DISCLOSED, IN WHOLE OR PART, TO ANY UNAUTHORIZED PERSON OR ENTITY NOR REPRODUCED, TRANSFERRED OR INCORPORATED IN ANY OTHER PROJECT IN ANY MANNER WITHOUT THE EXPRESS WRITTEN CONSENT OF SAMTEC, INC.

DO NOT SCALE DRAWING

SHEET SCALE: 4:1



520 PARK EAST BLVD, NEW ALBANY, IN 47150  
PHONE: 812-944-6733 FAX: 812-948-5047  
e-Mail info@SAMTEC.com code 55322

DESCRIPTION:  
.050 x .050 SURFACE MOUNT BOARD SPACERS

DWG. NO.  
FW-XX-XX-XX-D-XXX-XXX-XX

BY: BRATCHER 11-03-1994 SHEET 4 OF 4