

LOC	DIST	REVISIONS					
		P	LTN	DESCRIPTION	DATE	DMN	APVD
GP	00	D		REVISED PER ECO-10-004036	26FEB2010	CJV	MRS
		E		REVISED PER ECO-11-019224	05JAN2012	TX	AC
		E1		REVISED PER ECO-13-014600	10OCT2013	PP	SH

- 1 MATERIAL:  
 CAGE ASSEMBLY - NICKEL-SILVER ALLOY.  
 EMI SPRINGS - COPPER ALLOY.  
 HEATSINK - ALUMINUM ALLOY.  
 HEATSINK CLIP - STAINLESS STEEL.
- 2 FINISH:  
 HEATSINK - ELECTROLESS NICKEL.  
 HEATSINK CLIP - PASSIVATE.  
 EMI SPRINGS - 0.8µm MIN MATTE TIN OVER 0.8µm MIN NICKEL.  
 NON PLATED EDGES PERMISSIBLE.
3. MATES WITH SFP MSA COMPLIANT TRANSCEIVERS.
- 4 PADS AND VIAS CHASSIS GROUND.
- 5 DATUMS AND BASIC DIMENSIONS ESTABLISHED BY CUSTOMER.
6. MINIMUM PC BOARD THICKNESS:  
 SINGLE SIDED = 1.50mm
- 7 DIMENSIONS APPLIES PRIOR TO INSERTION OF SFP MODULE.
8. CAGE ASSEMBLY, HEATSINK CLIP AND HEATSINK SHIPPED ASSEMBLED.
9. NOTE DELETED

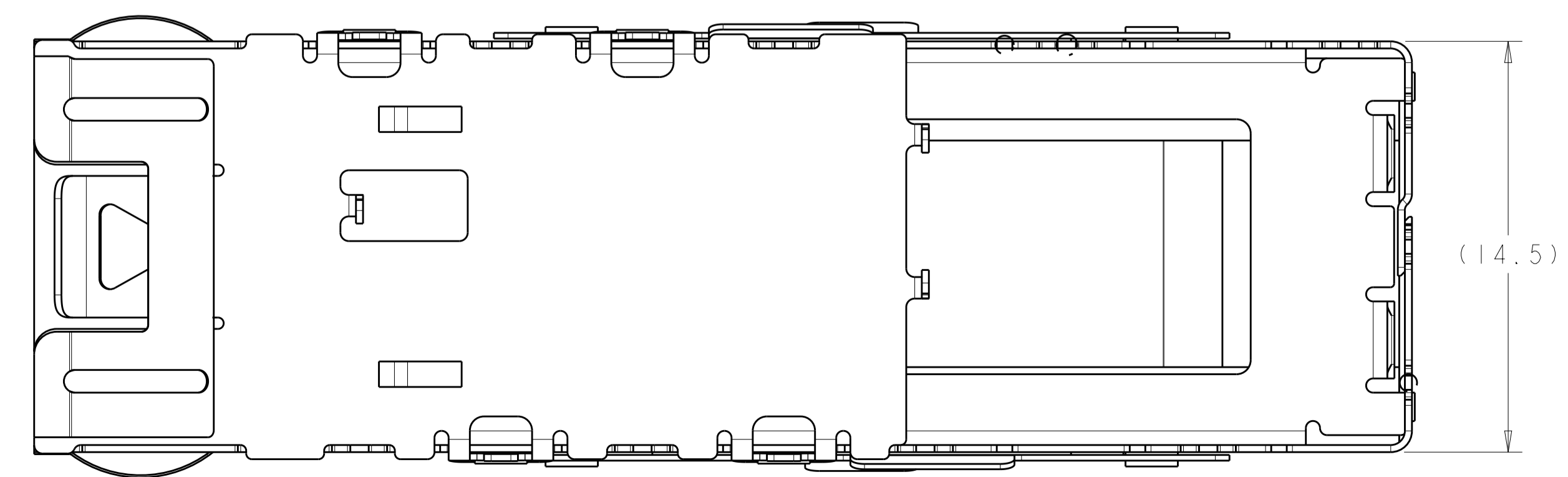
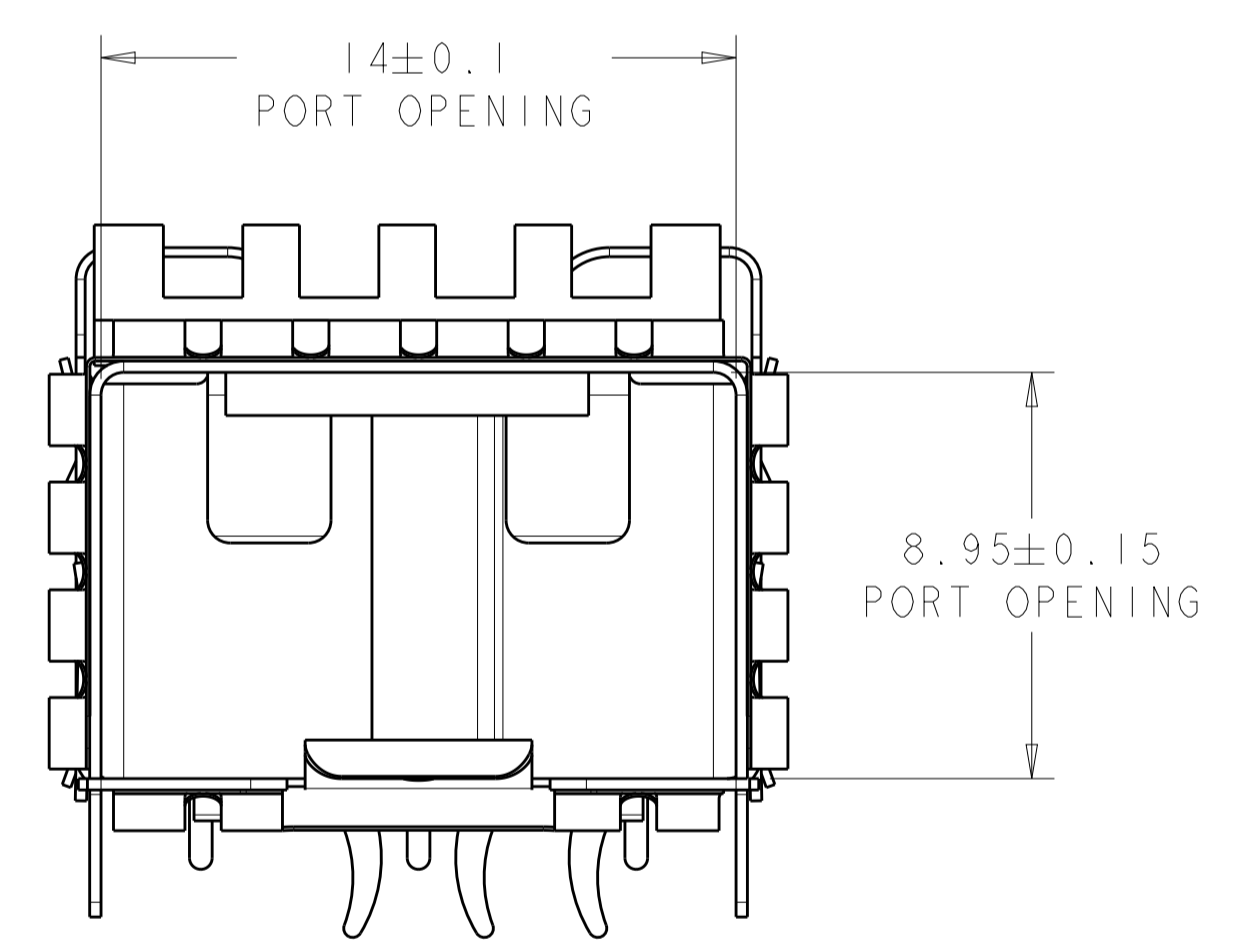
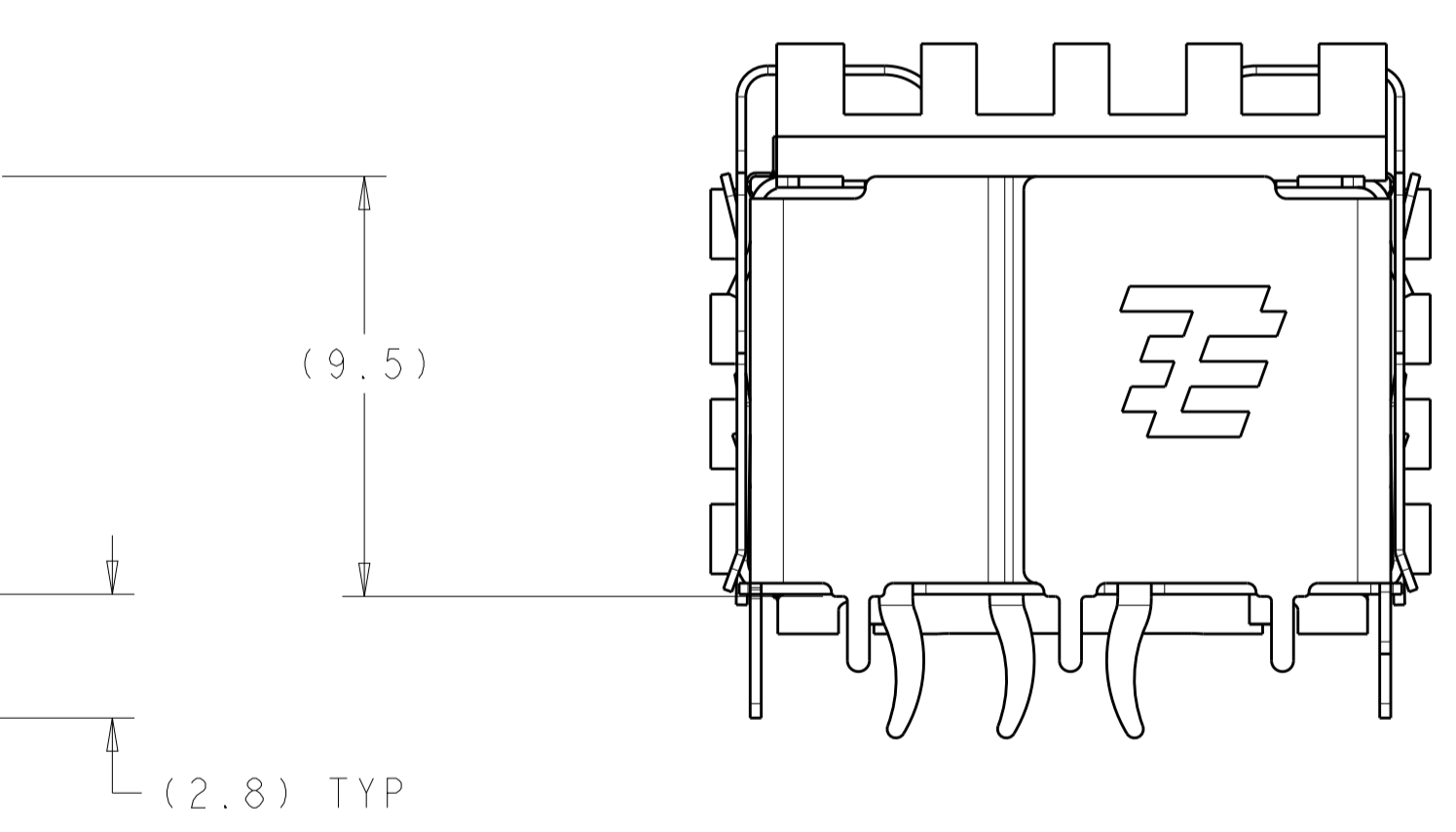
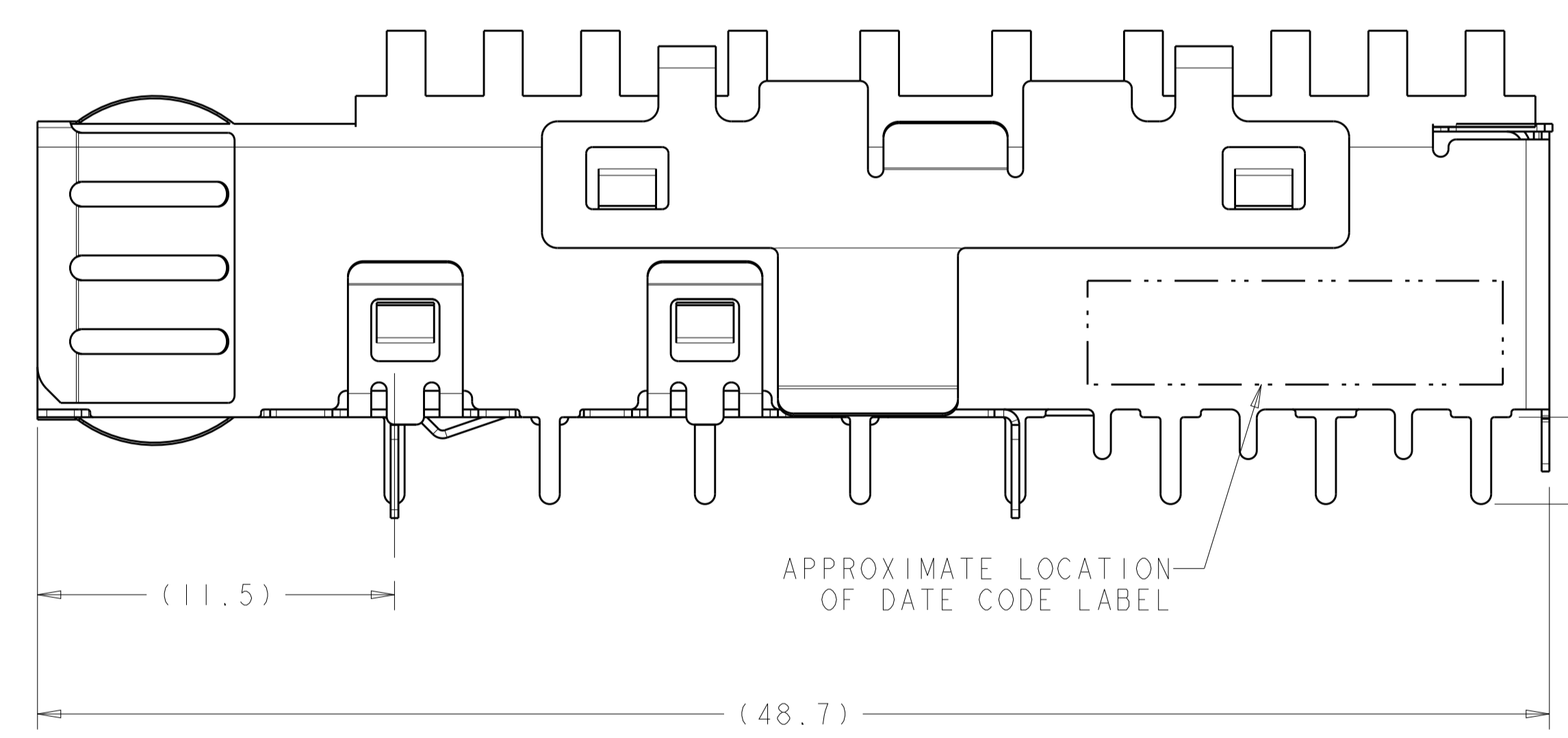
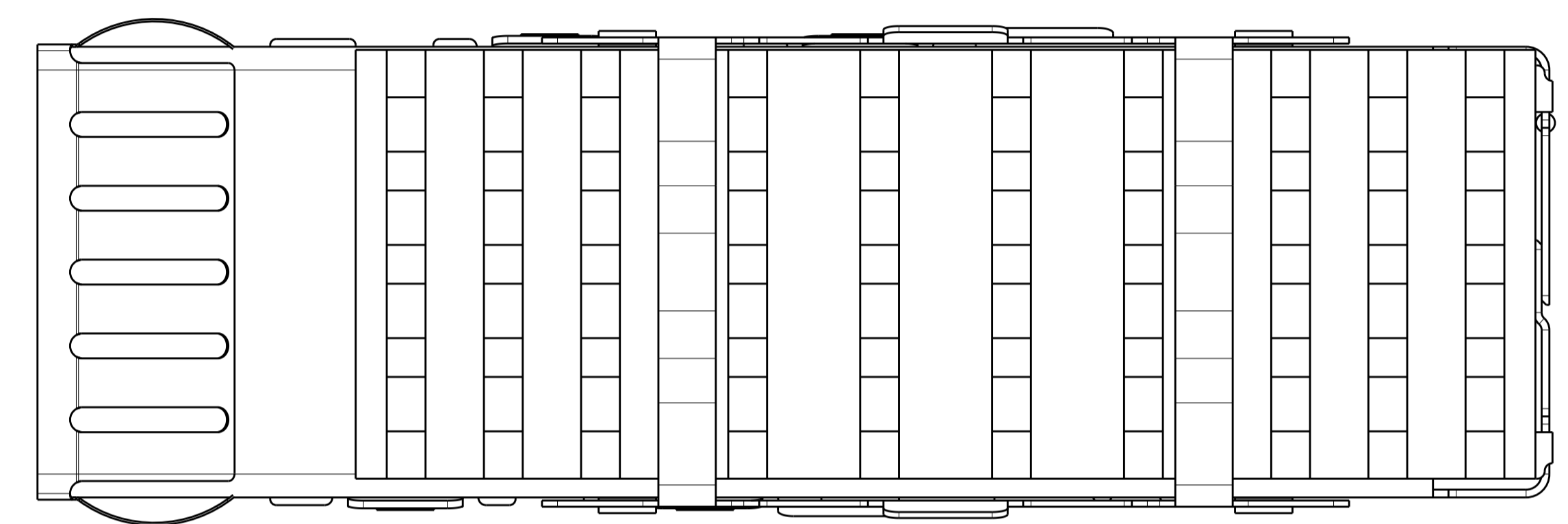
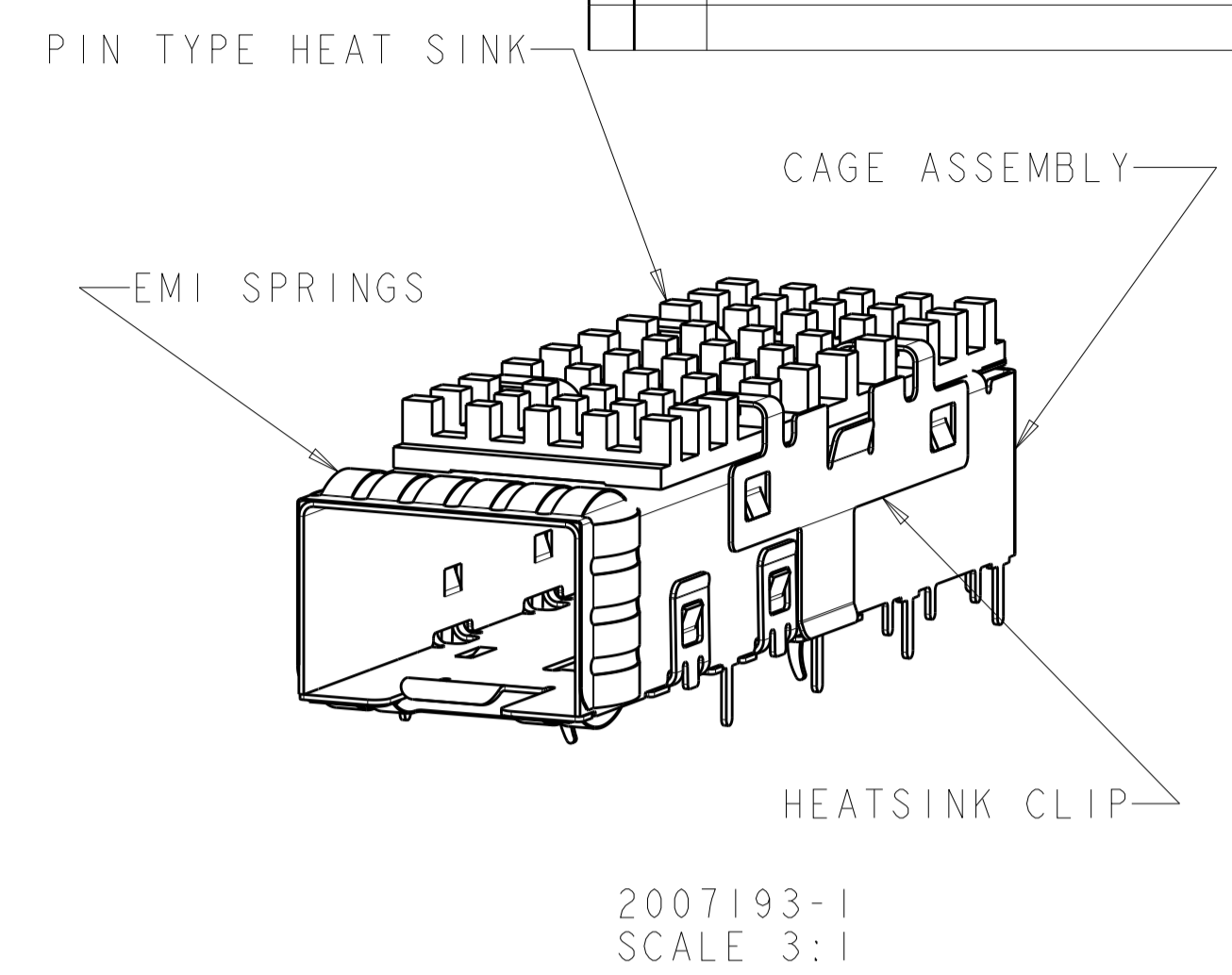
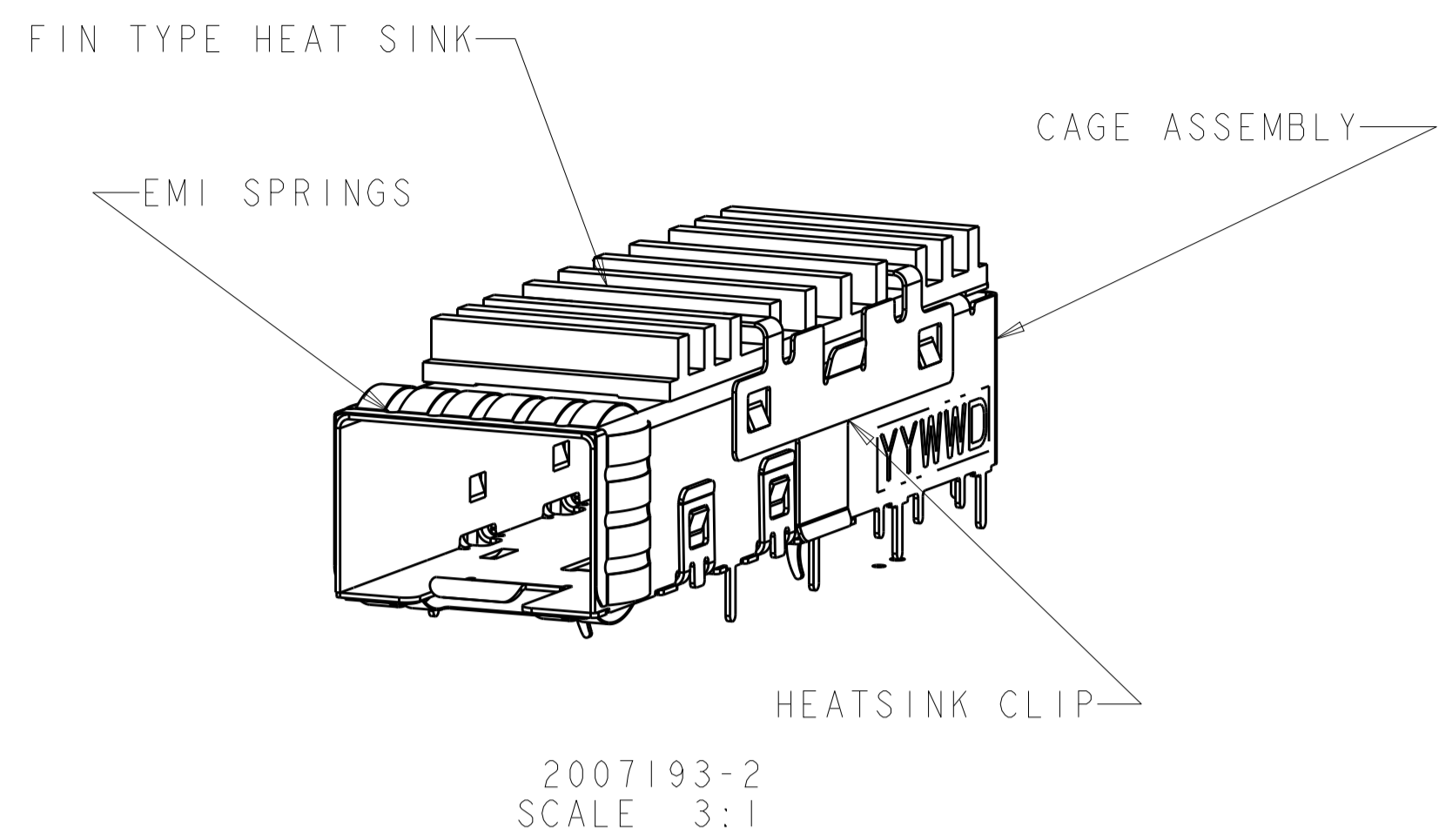

FIN TYPE HEAT SINK	2007193-2
PIN TYPE HEAT SINK	2007193-1
HEAT SINK	PART NUMBER

THIS DRAWING IS A CONTROLLED DOCUMENT.

DIMENSIONS:	TOLERANCES UNLESS OTHERWISE SPECIFIED:	DMN	Z. M. BEAM	10JUL2007
mm	0 PLC ±0.1	CHK	M. R. SCHMITT	10JUL2007
	1 PLC ±0.1	APVD	P. H. WERTZ	10JUL2007
	2 PLC ±0.1	PRODUCT SPEC		
	3 PLC ±0.05	108-2364		
	4 PLC ±0.05	APPLICATION SPEC		
	ANGLES ±0.05	114-13120		
MATERIAL	FINISH	WEIGHT		

Customer Drawing

TE Connectivity	
NAME	SFP+ 1X1 CAGE ASSY W/ HEATSINK PCI SOLDER TAILS EXTERNAL EMI SPRING FINGERS
SIZE	CAGE CODE DRAWING NO
A1	100779 ©=2007193
SCALE	6:1
SHEET	1 OF 2
REV	E1

LOC	DIST	REV	DATE	BY	APPV
GP	00				

REVISIONS			
NO.	DESCRIPTION	DATE	BY
1	SEE SHEET 1		

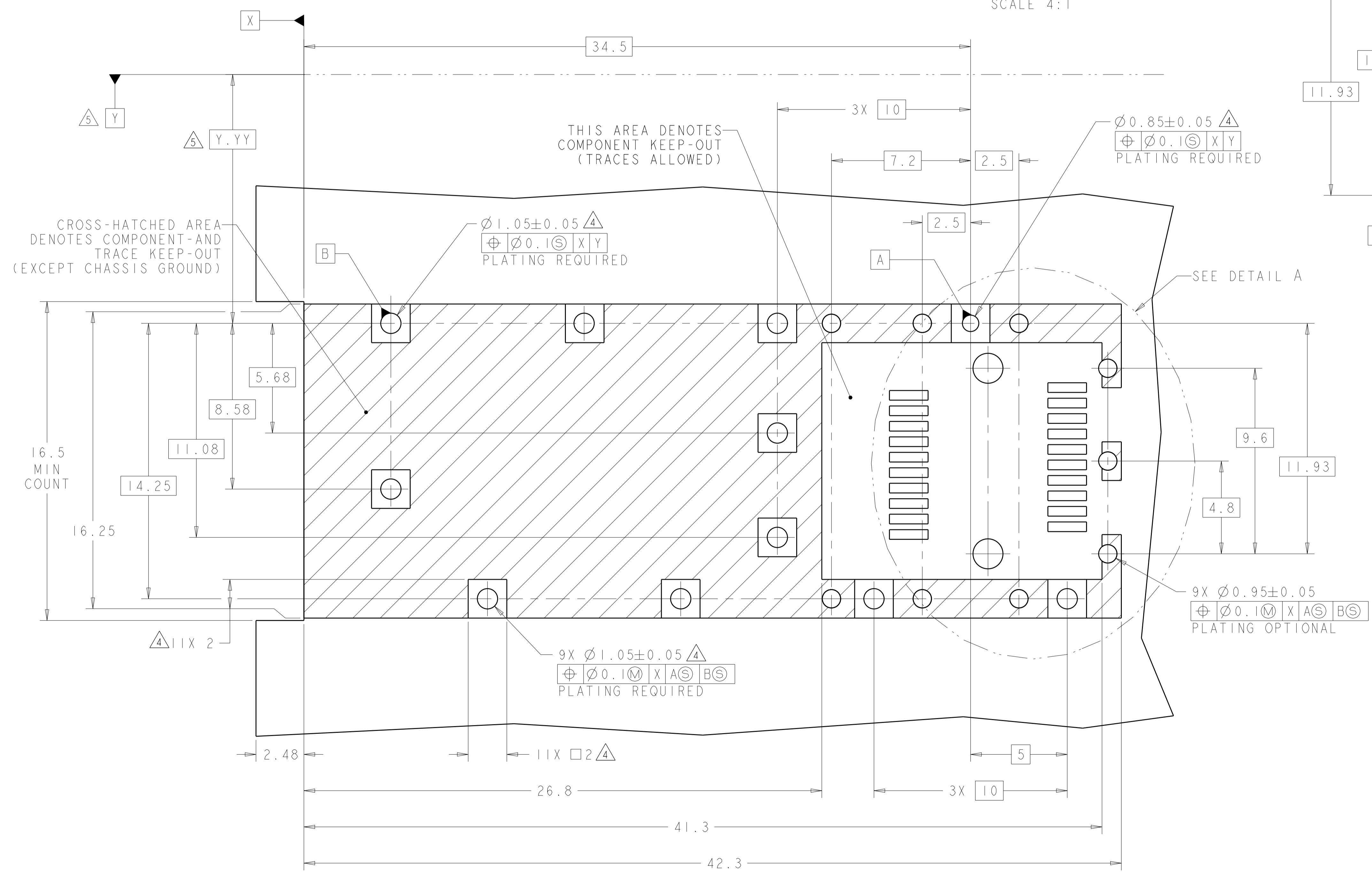
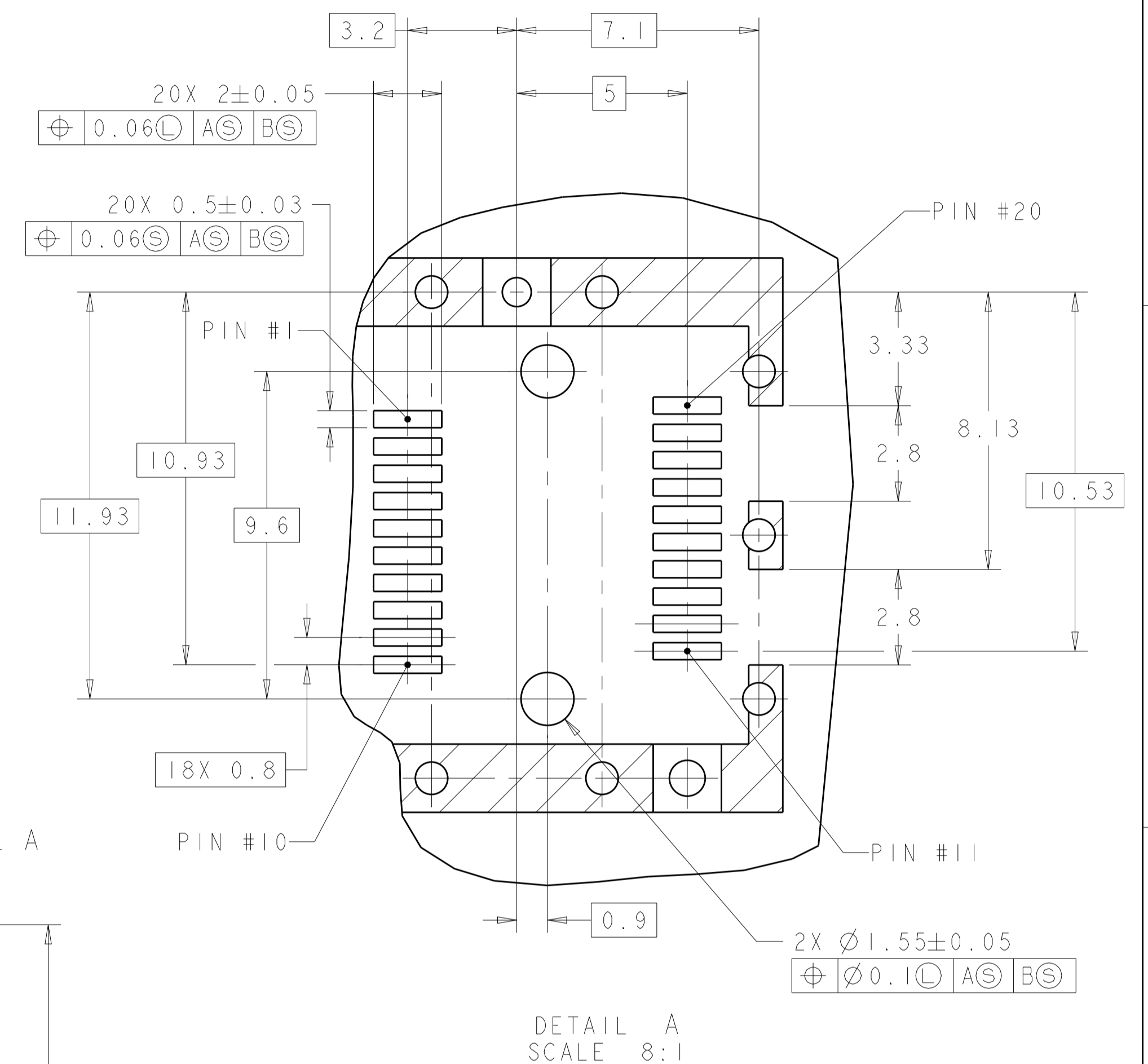
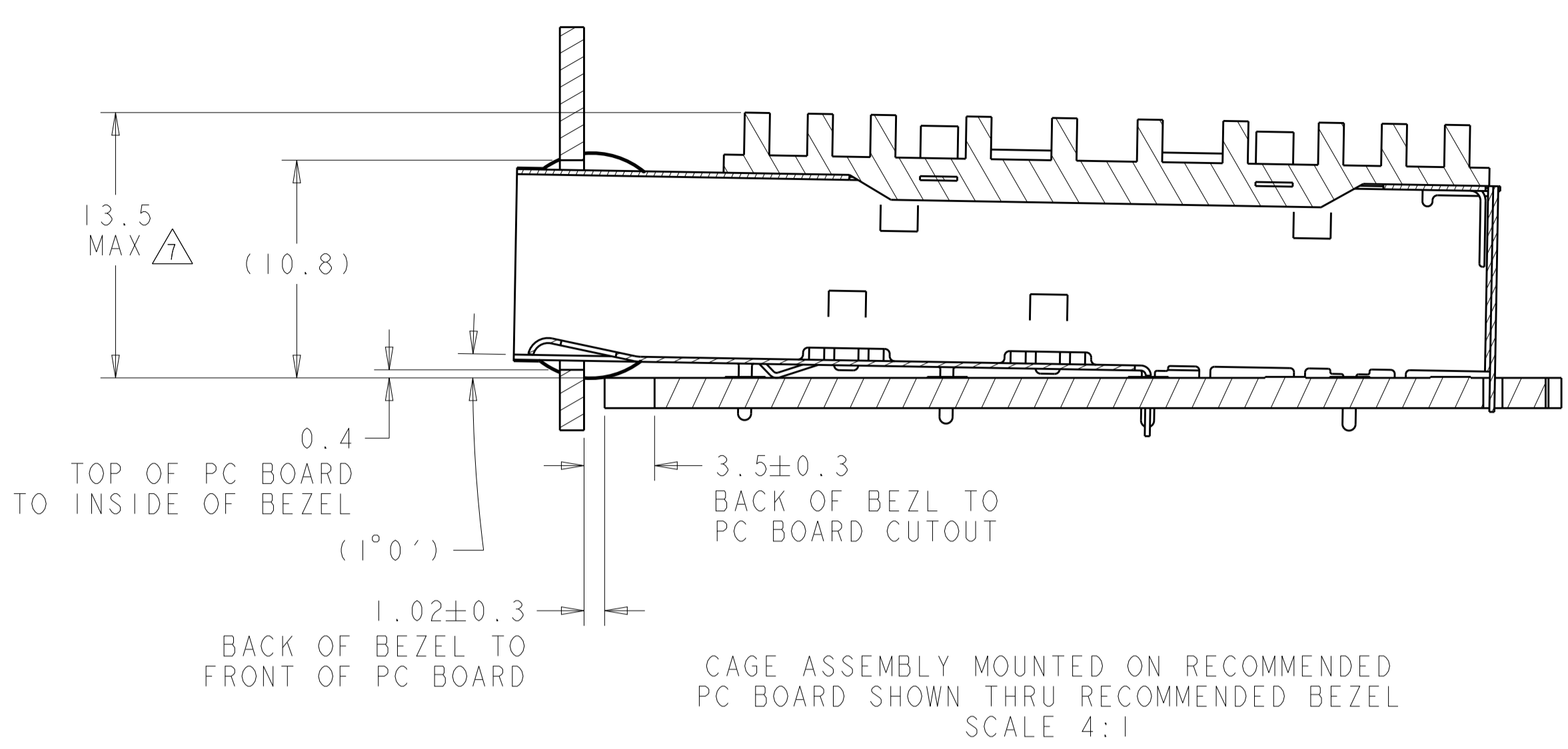
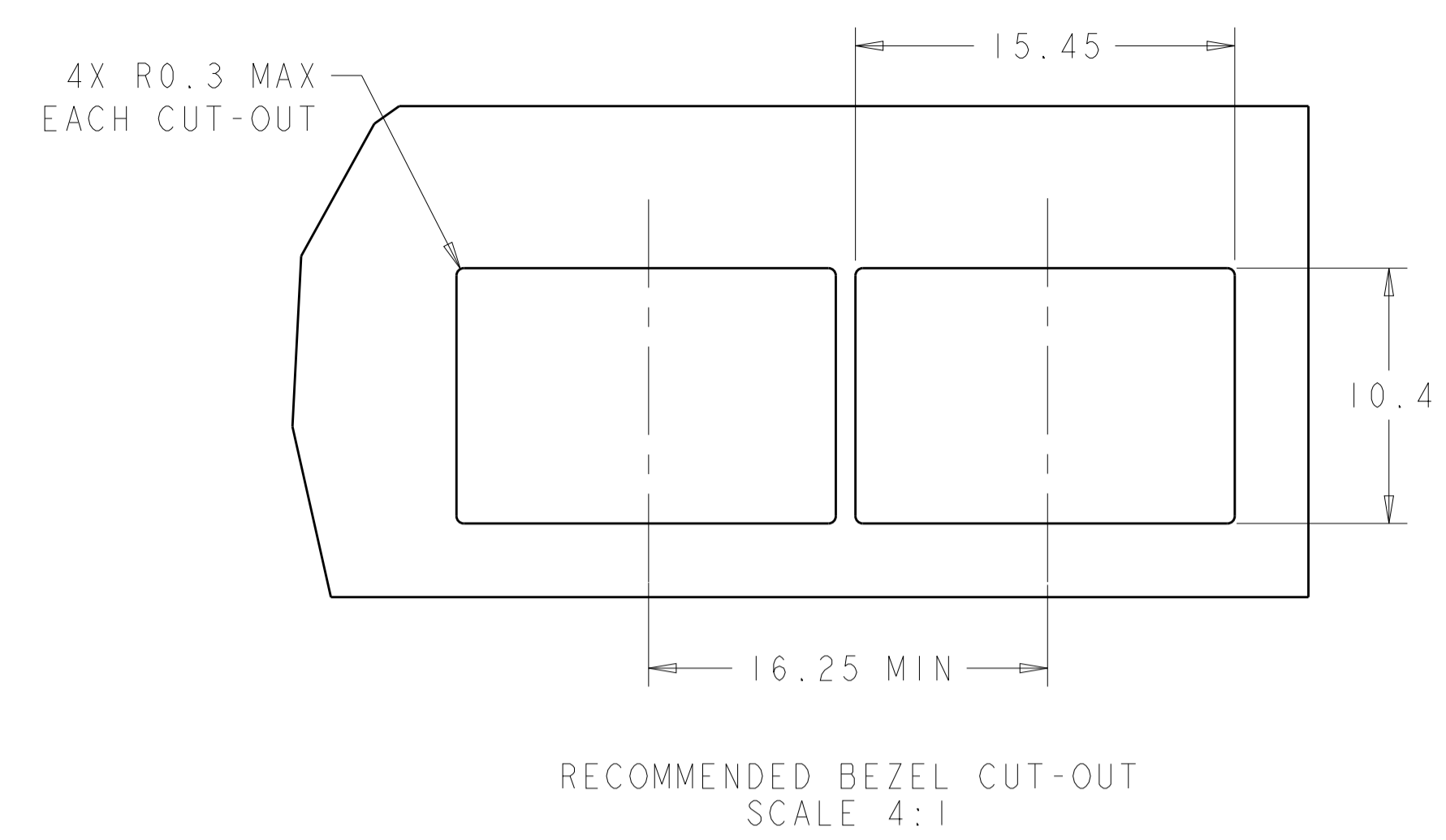

RECOMMENDED PCB LAYOUT SCALE 8:1

THIS DRAWING IS A CONTROLLED DOCUMENT.		OWN: Z.M.BEAM 10JUL2007	 TE Connectivity
DIMENSIONS: mm		CHK: M.B.SCHMITT 10JUL2007	
TOLERANCES UNLESS OTHERWISE SPECIFIED:		APPV: R.H.WERTZ 10JUL2007	
0 PLC ±0.1 1 PLC ±0.1 2 PLC ±0.1 3 PLC ±0.05 4 PLC ±0.05 ANGLES ±0.05		NAME: SFP+ 1X1 CAGE ASSY W/ HEATSINK PRODUCT SPEC: 108-2364 APPLICATION SPEC: 114-13120 WEIGHT: - Customer Drawing	
MATERIAL: -		SIZE: A100779	CAGE CODE: C=2007193 DRAWING NO: - SCALE: 6:1 SHEET: 2 OF 2 REV: E1

# Mouser Electronics

Authorized Distributor

Click to View Pricing, Inventory, Delivery & Lifecycle Information:

[TE Connectivity:](#)

[2007193-1](#)