

THIS DOCUMENT IS THE PROPERTY OF
KEYSTONE ELECTRONICS CORP. AND
SHALL NOT BE REPRODUCED, DISTRIBUTED
OR USED AS A BASIS FOR MANUFACTURE
WITHOUT PRIOR WRITTEN PERMISSION
FROM KEYSTONE ELECTRONICS CORP.

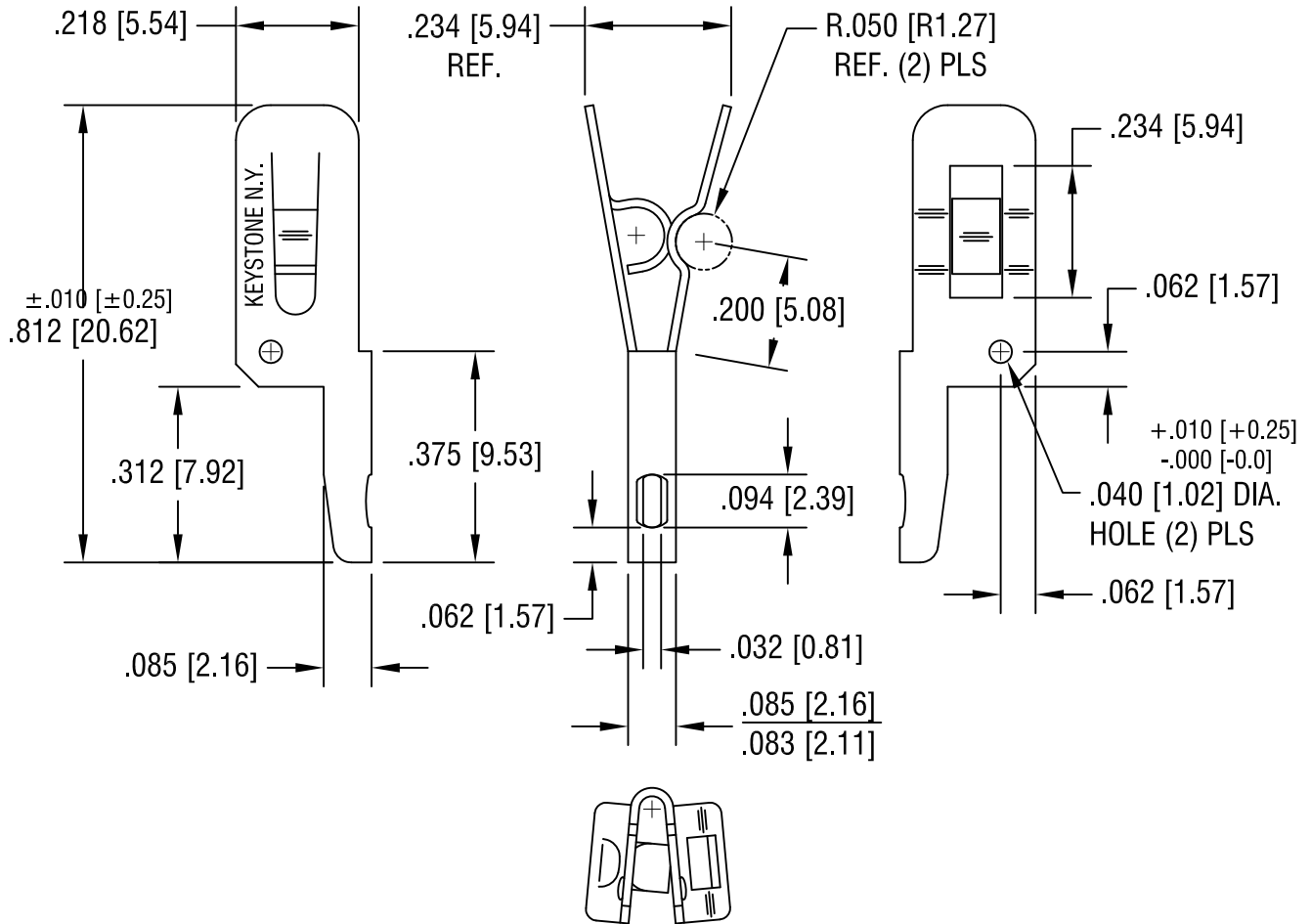

NOTE:

1. HEAT TREAT TO SPRING TEMPER
2. MOUNTS INTO .093 [2.36] DIA. HOLE

9.21.09	CHANGE AS PER ECN 09-130	B
9.28.00	CHANGE AS PER ECN 00-104	A
DATE	DESCRIPTION	REV.

KEYSTONE ELECTRONICS CORP.			
www.keyelco.com • ASTORIA, N.Y. 11105-2017 • Tel (718) 956-8900			
PART NAME		SOLDERLESS TERMINAL	
MATERIAL		.015 [.38] TH'K ANNEALED SPRING STEEL	
FINISH		DRN BY	DATE
MATTE TIN PLATE		BOONE	11.9.98
		APP'D	SCALE
		LN	3X
TOLERANCES	INCH [MM]	CODE	DWG NO.
DECIMAL	± .005 [± 0.15]	C	1498CP
ANGULAR	± 1°		
UNLESS OTHERWISE SPECIFIED			

Mouser Electronics

Authorized Distributor

Click to View Pricing, Inventory, Delivery & Lifecycle Information:

[Keystone Electronics:](#)

[1498CP](#)