



ON Semiconductor®

<http://onsemi.com>

# STK681-332-E

Thick-Film Hybrid IC

## Forward/Reverse Motor Driver

### Overview

The STK681-332-E is a hybrid IC for use in current control forward/reverse DC motor driver with brush.

### Applications

- Office photocopiers, printers, etc.

### Features

- Allows forward, reverse, and brake operations in accordance with the external input signal.
- 12A peak startup output current and 12A peak brake output current.
- On-chip output short-circuit detection function.
- Connecting an external current detection resistor allows overcurrent detection and peak current control in the PWM operation mode.
- Obviate the need to design for the dead time in order to turn off the upper- and lower drive devices when switching between the forward and reverse operation mode.

### Specifications

**Absolute maximum ratings** at  $T_c = 25^\circ\text{C}$

Parameter	Symbol	Conditions	Ratings	unit
Maximum supply voltage 1	$V_{CC}$ max	$V_{DD}=0\text{V}$	52	V
Maximum supply voltage 2	$V_{DD}$ max	No signal	-0.3 to +6.0	V
Input voltage	$V_{IN}$ max	Logic input pins	-0.3 to +6.0	V
Output current1	$I_{O1}$ max	$V_{DD}=5.0\text{V}$ , DC current	8.5	A
Output current2	$I_{O2}$ max	$V_{DD}=5.0\text{V}$ , Pulse current: 5ms	12	A
Brake current	$I_{OB}$ max	$V_{DD}=5.0\text{V}$ , square wave current, operating time 15ms (single pulse, low side brake)	12	A
Allowable power dissipation	$P_{dPK}$ max	No heat sink	2.8	W
Operating substrate temperature	$T_c$	Metal surface temperature of the package	-20 to +105	$^\circ\text{C}$
Junction temperature	$T_j$ max		150	$^\circ\text{C}$
Storage temperature	$T_{stg}$		-40 to +125	$^\circ\text{C}$

Stresses exceeding Maximum Ratings may damage the device. Maximum Ratings are stress ratings only. Functional operation above the Recommended Operating Conditions is not implied. Extended exposure to stresses above the Recommended Operating Conditions may affect device reliability.

### ORDERING INFORMATION

See detailed ordering and shipping information on page 14 of this data sheet.

## STK681-332-E

### Allowable Operating Ranges at $T_a = 25^\circ\text{C}$

Parameter	Symbol	Conditions	Ratings	unit
Operating supply voltage 1	$V_{CC1}$	With signals applied ( $T_c=105^\circ\text{C}$ )	10 to 38	V
Operating supply voltage 2	$V_{CC2}$	With signals applied ( $T_c=90^\circ\text{C}$ )	10 to 42	V
Operating supply voltage 2	$V_{DD}$	With signals applied	$5\pm 5\%$	V
Input voltage	$V_{IN}$		0 to $V_{DD}$	V
Output current 1	$I_{O1}$	$V_{DD}=5.0\text{V}$ , DC current, $T_c=80^\circ\text{C}$	6.1	A
Output current 2	$I_{O2}$	$V_{DD}=5.0\text{V}$ , DC current, $T_c=105^\circ\text{C}$	5	A
Brake current	$I_{OB}$	$V_{DD}=5.0\text{V}$ , square wave current, operating time 2ms, Low side brake, $T_c=105^\circ\text{C}$	12	A

Refer to the graph for each conduction-period tolerance range for the output current and brake current.

### Electrical Characteristics at $T_c = 25^\circ\text{C}$ , $V_{CC} = 24\text{V}$ , $V_{DD} = 5.0\text{V}$

Parameter	Symbol	Conditions	min	typ	max	unit
$V_{DD}$ supply current	$I_{CCO}$	Forward or reverse operation		6	9	mA
FET diode forward voltage	$V_{df}$	$I_f=1\text{A}$ ( $R_L=23\Omega$ )		0.75	1.4	V
Output saturation voltage 1	$V_{sat1}$	$R_L=23\Omega$ , F1, F2		65	100	mV
Output saturation voltage 2	$V_{sat2}$	$R_L=23\Omega$ , F3, F4		50	85	mV
Output leak current	$I_{OL}$	F1, F2, F3, and F4 OFF operation			50	$\mu\text{A}$
Input high voltage	$V_{IH}$	IN1, IN2, ENABLE pins	2.5			V
Input low voltage	$V_{IL}$	IN1, IN2, ENABLE pins			0.8	V
High-level input current	$I_{IH}$	IN1, IN2, ENABLE pins, $V_{IH}=5\text{V}$		50	75	$\mu\text{A}$
Low-Level Input current	$I_{IL}$	IN1, IN2, ENABLE pins, $V_{IL}=\text{GND}$			10	$\mu\text{A}$
Overcurrent detection voltage	VOC	Between pins $V_{ref1}$ and S.P		0.48		V
Internal PWM frequency	$f_c$		32	46	62	kHz
Overheat detection temperature	TSD	Design guarantee		144		$^\circ\text{C}$

Note: A fixed-voltage power supply must be used.

Package Dimensions

unit:mm (typ)

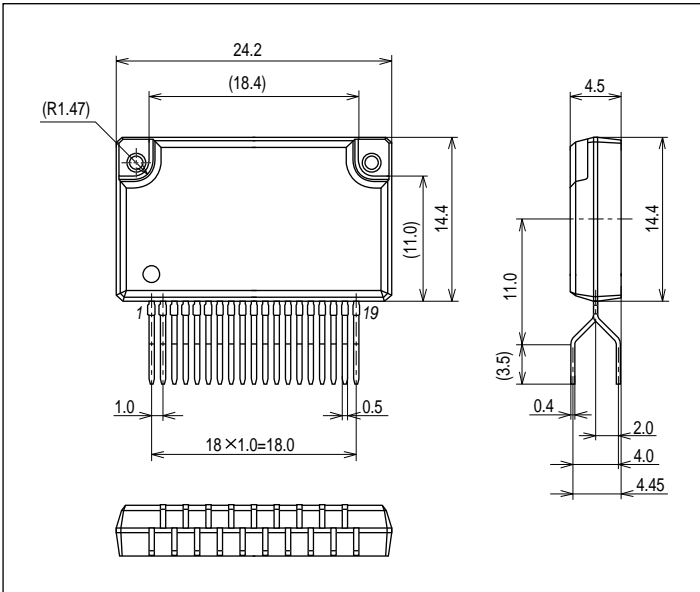

Derating Curve of Motor Current,  $I_O$ , vs. STK681-332-E Operating Board Temperature,  $T_c$

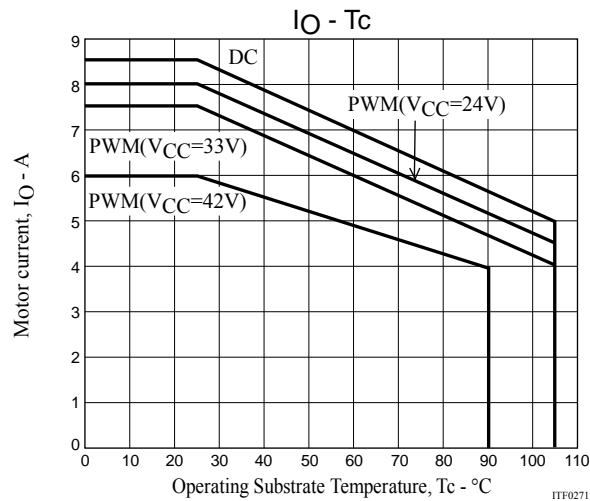

(The maximum PWM frequency is 50kHz.)

The PWM frequencies in the above graph indicate the ENABLE signal.

The same PWM  $I_O$  derating curves as those shown above will be obtained when the internal PWM frequency of the STK681-332-E is used.

Increasing the  $V_{CC}$  supply voltage narrows the  $I_O$  derating curve range, so  $I_O$  should be set in reference to the above graph.

The above operating substrate temperature,  $T_c$ , is measured immediately when the motor is started.

Since  $T_c$  fluctuates due to the ambient temperature,  $T_a$ , the motor current value, and continuous or intermittent operations of the motor current, always confirm this values using an actual set.

The  $T_c$  temperature should be checked in the center of the metal surface of the product package.

# STK681-332-E

STK681-332-E Allowable Brake Current Range (Low side: F3, F4=ON)

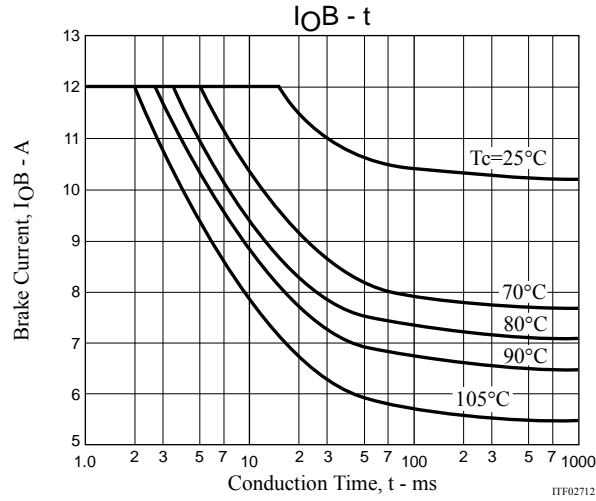

STK681-332-E Allowable Brake Current Range (High side: F1, F2=ON)

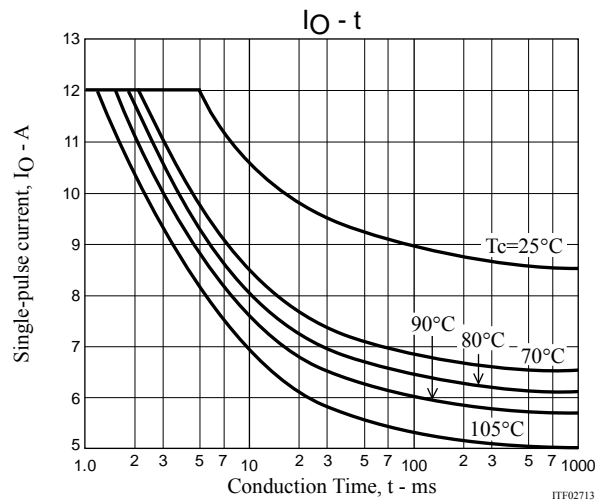

The output current specifications are the same as the high side brake current specifications.

Internal Block Diagram

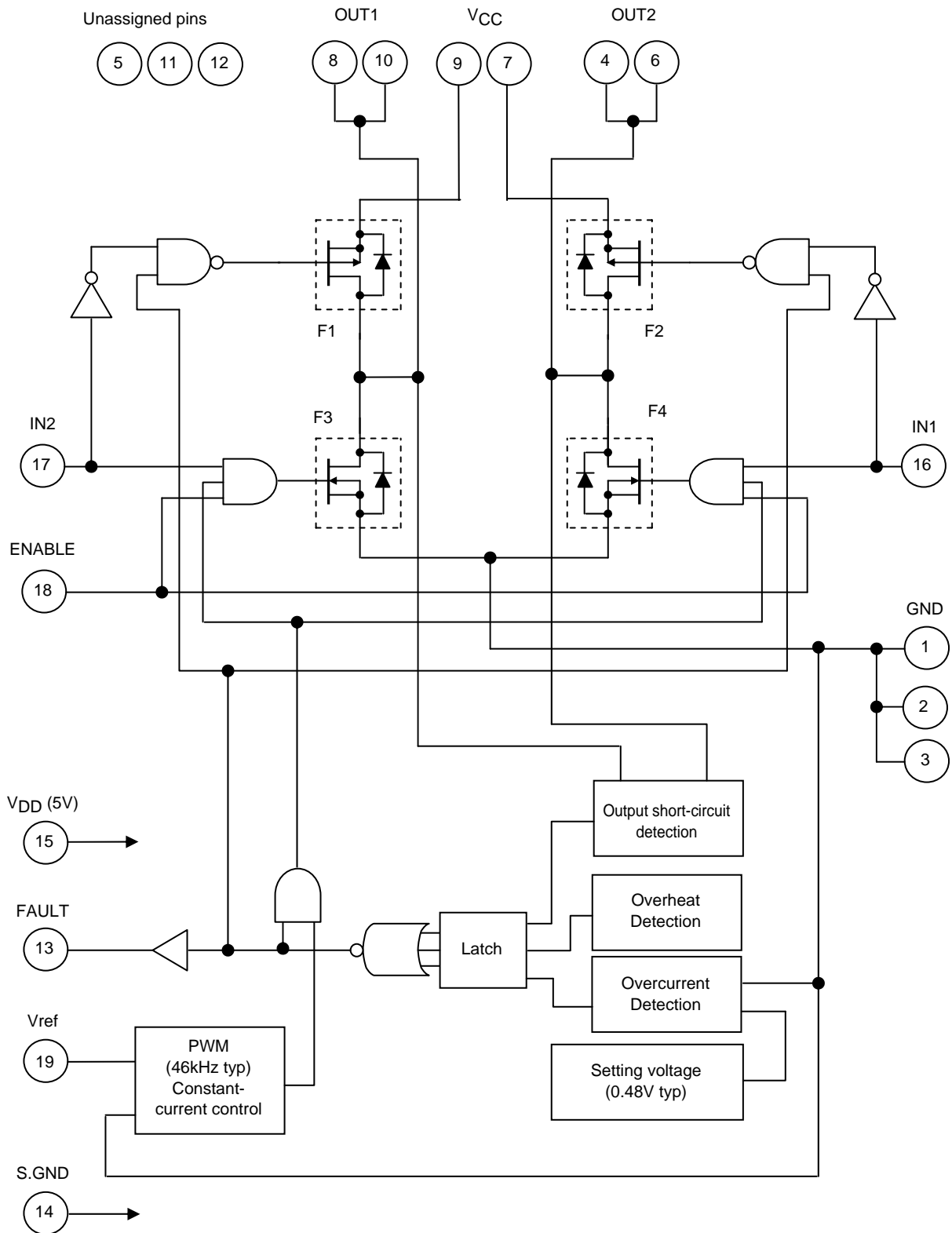

Sample Application Circuit

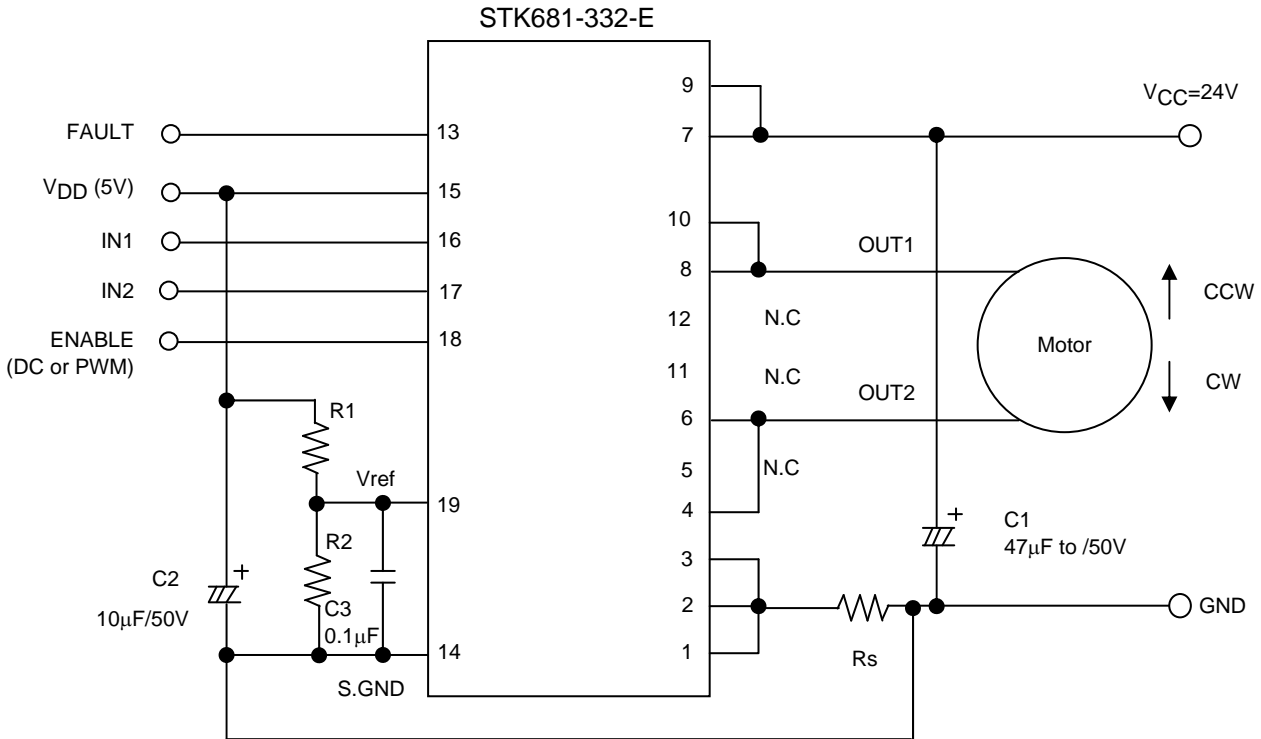

Motor Drive Conditions (H: High-level input; L: Low-Level Input)

	IN1	IN2	ENABLE	Remarks
Stop	H	L	L	Turns the power supply OFF. ENABLE must be set Low when V <sub>DD</sub> is rising or falling.
	L	H	L	
	H	H	L	
Forward (CW)	H	L	H	No input signal is needed that turns off the upper- and lower-side drive devices when switching the rotational direction.
Reverse (CCW)	L	H	H	
Brake	L	L	L or H	GND side MOSFET ON
	H	H	H	V <sub>CC</sub> side MOSFET ON

\* Output control is enabled by applying an external PWM signal to the ENABLE pin.  
 The product can run at a minimum external PWM pulse width of 1µs. In the case when the high pulse width is less than 16µs, however, the IC may fail to detect a short-circuit condition when an output short-circuit occurs.  
 If V<sub>DD</sub> is turned off in the condition with the ENABLE pin set to high during motor rotation or PWM operation, the FAULT signal is output when V<sub>DD</sub> is falling, indicating error condition. For this reason, ENABLE must be set to low when V<sub>DD</sub> is rising or falling.  
 When both IN1 and IN2 are set low, the MOSFET on the V<sub>CC</sub> side is driven. To minimize the loss when stopped, set IN1 = IN2 = High and ENABLE = Low to turn off the gate signal to the V<sub>CC</sub> side MOSFETs.

Setting the current limit using the Vref pin

$$\text{Output current peak (Iop)} = (\text{Vref} \div 4.9) \div \text{Rs}$$

“4.9” in the above formula indicates the portion of the Vref voltage that is divided using the circuit inside the control IC.

$$\text{Vref} = (\text{R2} \div (\text{R1} + \text{R2})) \times \text{VDD}$$

Rs is the external current detection resistance value of the HIC, and Vref ≤ 2.0V must be satisfied so that overcurrent detection is not triggered.

## STK681-332-E

### Notes

- (1) Be sure to set the capacitance of the power supply bypass capacitor, C1, so that the ripple current of the capacitor, which varies as motor current increases, falls within the allowed range.
- (2) Chopping operations based on F3 and F4 are used for current control. The timing given below is used for OUT1 or OUT2 voltage output and for F3 or F4 drain current.
- (3) Do not connect the N.C pins (5, 11, 12 pin) shown in the internal block diagram or sample application circuit to a circuit pattern on the PCB.

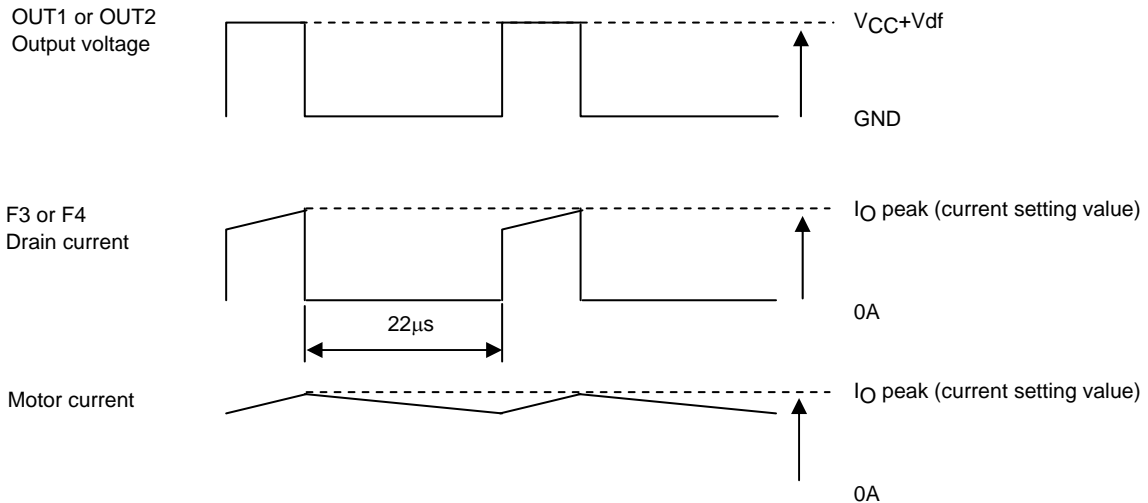

### (4) Sample Timing Diagram

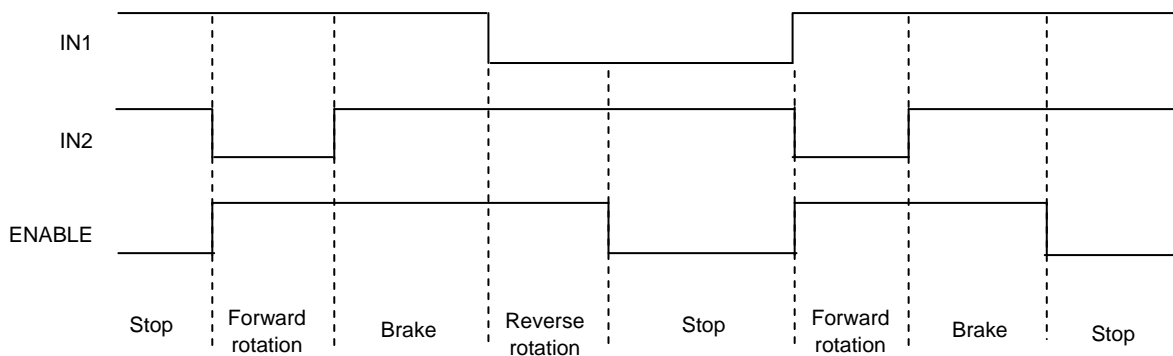

- (5) If the current detection resistor,  $R_s$ , connected to pin1, pin2, and pin3 is short-circuited, the overcurrent detection circuit does not operate. If the output pin is short-circuited directly to  $V_{CC}$  or connected directly to GND, an output short-circuit condition is detected and the output is latched in the off state. To restart the operation, turn on  $V_{DD}$  again.
- (6) Smoke Emission Precautions: There is a possibility of smoke emission if the hybrid IC is subjected to physical or electrical damage as the result of being used without compliance with the specifications.

## STK681-332-E

### I/O Functions of Each Pin

Pin Name	Pin No.	Function
IN1	16	Input pin for turning F2 and F4 ON and OFF At low level F2: ON and F4: OFF; at high level, F2: OFF and F4: ON
IN2	17	Input pin for turning F1 and F3 ON and OFF At low level F1: ON and F3: OFF; at high level, F1: OFF and F3: ON
ENABLE	18	Pin for turning F3 and F4 ON; At high level F31 and F42: ON ENABLE must be set Low when $V_{DD}$ is rising and falling. ENABLE must be set High to drive the motor.
FAULT	13	Monitor pin used when either of the output short-circuit detector, overcurrent detector, or overheat detector is activated. When the detector is activated, this pin is set low and all of F1, F2, F3 and F4 in the final stage are latched off.
OUT1	8, 10	This pin connects to the motor and outputs source/sync current depending on conditions at IN1 and IN2.
OUT2	4, 6	This pin connects to the motor and outputs source/sync current depending on conditions at IN1 and IN2.
Vref	19	This pin limits the peak current when motor startup. The current setting voltage, Vref, is set to the value of 4.9 times the voltage drop of the external current detection resistor. The internal overcurrent detection level is 0.48V, so setting Vref < 2.0V is recommended.
GND	1, 2, 3	Power system ground
S.GND	14	Control system ground
V <sub>CC</sub>	7, 9	Motor system supply voltage
V <sub>DD</sub>	15	Control system supply voltage.



**Technical Information**

1. Configuration of each pins <Configuration of the IN1, IN2, and ENABLE input pins>

Input pins: 16, 17, 18 pin

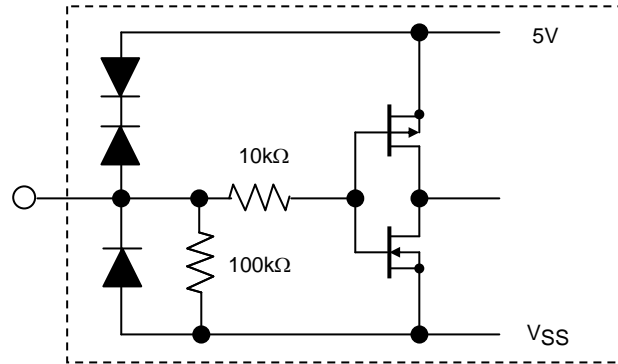

The input pins of this driver all use Schmitt input. Typical specifications at Tc=25°C are given below. Hysteresis voltage is 0.3V (VIHa-VILa).

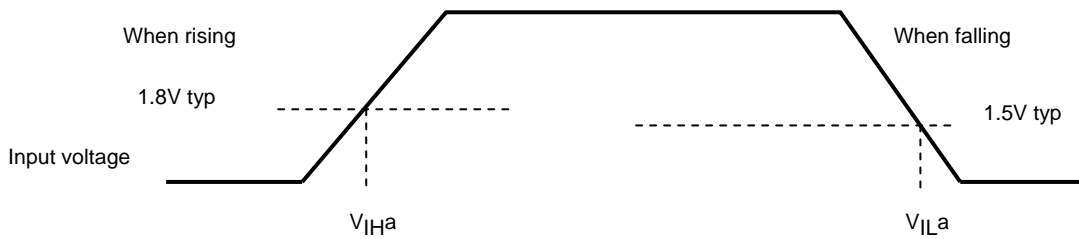

Input voltage specifications are as follows.

VIH=2.5V min

VIL=0.8V max

<Configuration of the FAULT input pin>

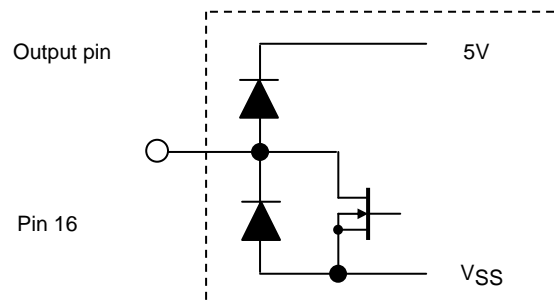

<Configuration of the Vref input pin>

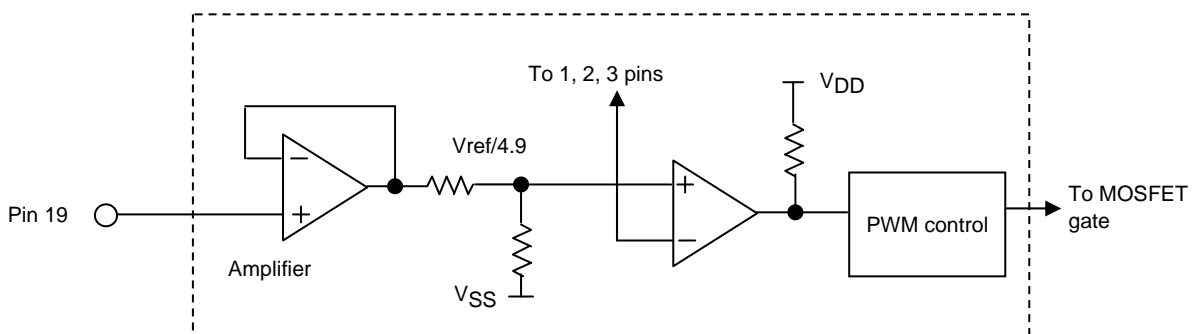

[Reduced voltage detection]

(1)  $V_{DD}$

The internal control IC of the driver has a function that detects reduced voltage when  $V_{DD}$  is supplied. This reduced voltage threshold level is set to 4V (typ.), and the MOSFET gate voltage specification is 5V  $\pm$ 5%. So, a current flow through the output when  $V_{DD}$  is rising results in the power stress to the MOSFET due to insufficient gate voltage. To prevent this power stress, set ENABLE = Low when  $V_{DD} < 4.75V$ , which is outside the normal operating supply voltage range of the MOSFET.

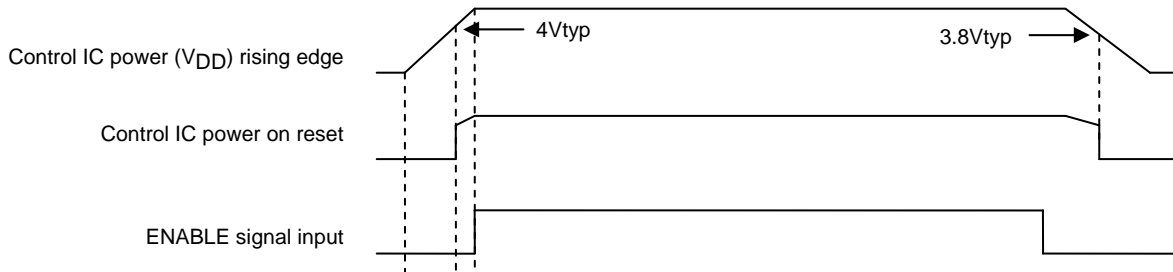

$V_{DD}$ , ENABLE Signals Input Timing

(2)  $V_{CC}$

The internal control IC of the driver has a function that detects reduced voltage when  $V_{CC}$  is supplied, to prevent insufficient internal P-channel MOSFET gate voltage. The reduced voltage detection level is set to  $V_{CC} = 8.8V$  (typ.).

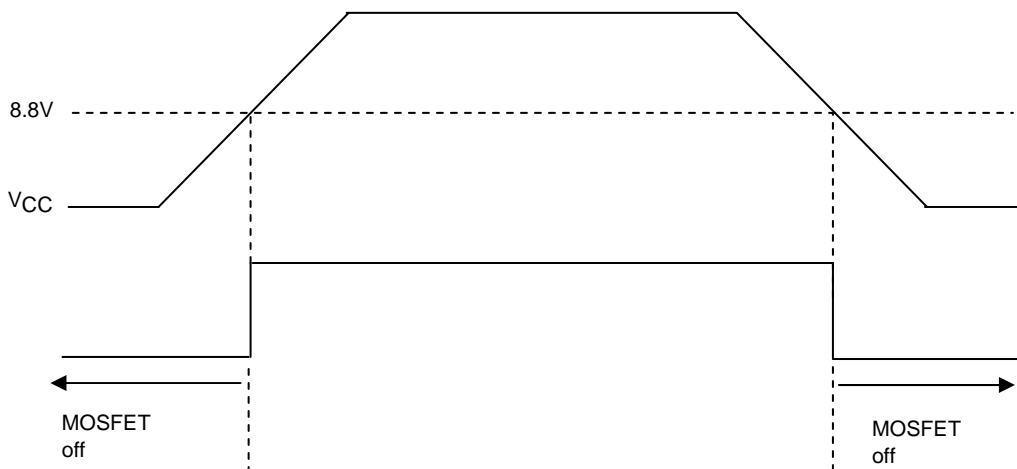

## 2. Output short-circuit detection, Overcurrent Detection and Overheat Detection

Each detection function operates using a latch system and turns output off. To restore output operation, turn the  $V_{DD}$  power supply off and then on again to apply a power-on reset.

### [Output Short-circuit Detection, Overcurrent Detection]

When the output pin is simply connected to the circuit GND or  $V_{CC}$ , or when the output load is short-circuited, the output short circuit detector must be activated and turn the output off.

Constant current PWM control can be performed by connecting a current detection resistor to pins 1, 2 and 3, and setting the  $V_{ref}$  pin voltage to less than 2.0V. In addition, when this current detection resistor voltage exceeds 0.48V (typ.), the overcurrent detector is activated and shuts the output off.

### [Overheat Detection]

Rather than directly detecting the temperature of the semiconductor device, overheat detection detects the temperature of the aluminum substrate (144°C typ).

Within the allowed operating range of  $I_{O1}$  (6.1A) recommended in the specifications, if a heat sink attached for the purpose of reducing the operating substrate temperature,  $T_c$ , comes loose, the semiconductor can operate without breaking.

However, we cannot guarantee operations without breaking in the case of operation other than those recommended, such as operations at a current exceeding  $I_{OH\ max}$  (6.1A) that occurs before overcurrent detection is activated.

## 3. Mitigated Curve of Package Power Loss, PdPK, vs. Ambient Temperature, Ta

Package power loss, PdPK, refers to the average internal power loss, PdAV, allowable without a heat sink. The figure below represents the allowable power loss, PdPK, vs. fluctuations in the ambient temperature, Ta. Power loss of up to 2.8W is allowable at  $T_a=25^\circ\text{C}$ , and of up to 1.5W at  $T_a=60^\circ\text{C}$ .

Allowable power dissipation, PdPK (no heat sink) - Ambient temperature, Ta

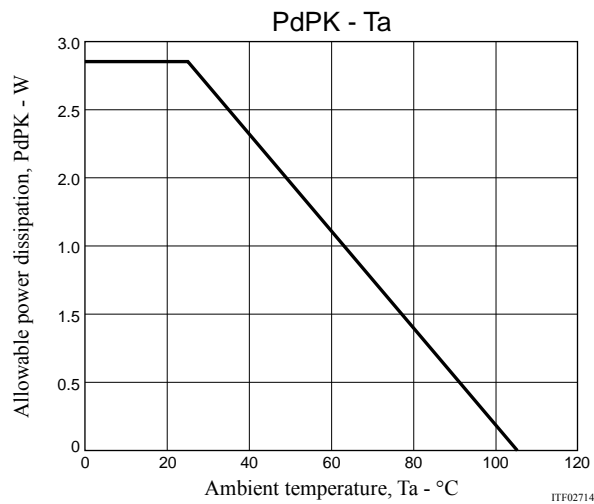

4. Data

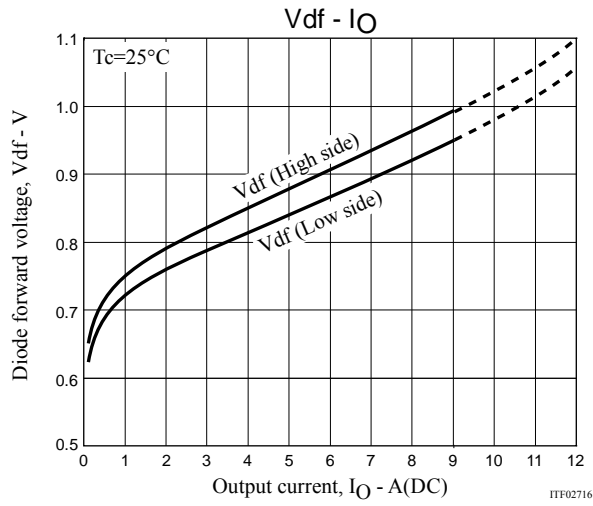
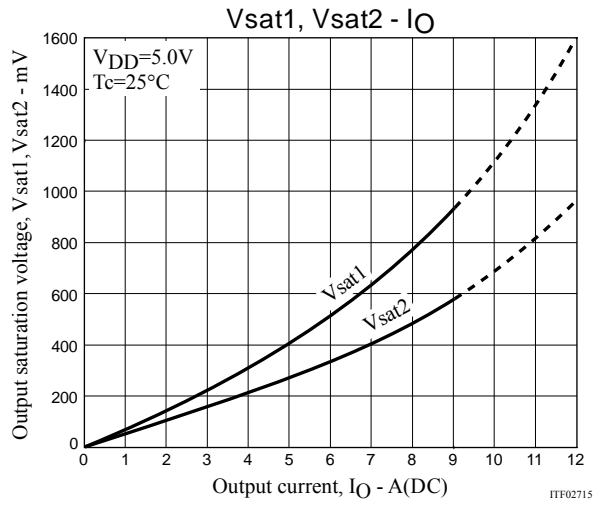

5. Other Notes on Use

In addition to the “Notes” indicated in the Sample Application Circuit, care should also be given to the following contents during use.

(1) Allowable operating range

Operation of this product assumes use within the allowable operating range. If a supply voltage or an input voltage outside the allowable operating range is applied, an overvoltage may damage the internal control IC or the MOSFET. If a voltage application mode that exceeds the allowable operating range is anticipated, connect a fuse or take other measures to cut off power supply to the product.

(2) Input pins

If the input pins are connected directly to the PC board connectors, electrostatic discharge or other overvoltage outside the specified range may be applied from the connectors and may damage the product. Current generated by this overvoltage can be suppressed to effectively prevent damage by inserting 100Ω to 1kΩ resistors in lines connected to the input pins.

Take measures such as inserting resistors in lines connected to the input pins

(3) Power connectors

If the motor power supply  $V_{CC}$  is applied by mistake without connecting the GND part of the power connector when the product is operated, such as for test purposes, an overcurrent flows through the  $V_{CC}$  decoupling capacitor, C1, to the parasitic diode between the  $V_{DD}$  of the internal control IC and GND, and may damage the power supply pin block of the internal control IC.

Always connect the GND pin before supplying  $V_{CC}$ .

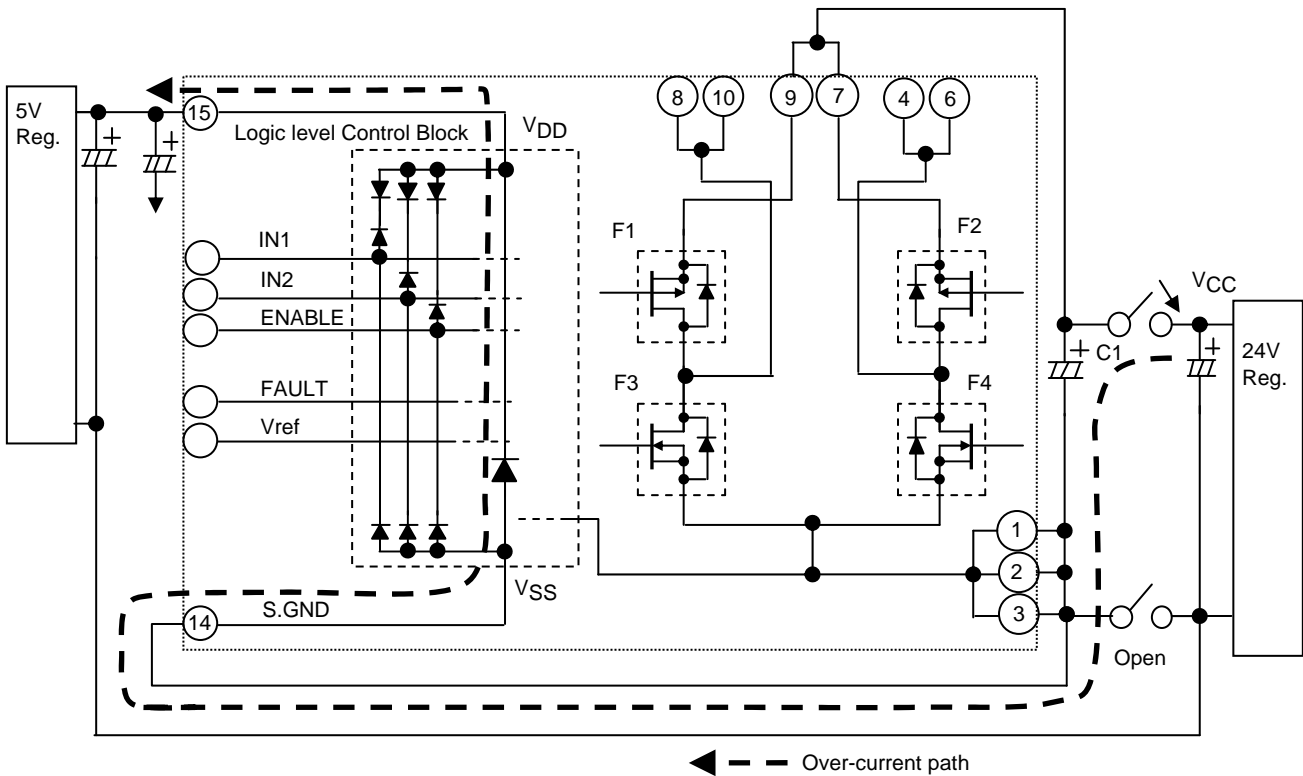

(4) Input Signal Lines

- 1) Do not use an IC socket to mount the driver, and instead solder the driver directly to the PC board to minimize fluctuations in the GND potential due to the influence of the resistance component and inductance component of the GND pattern wiring.
- 2) To reduce noise due to electromagnetic induction to small signal lines, do not design small signal lines (sensor signals, 5V or 3.3V power supply signal lines) that run parallel near the motor output lines OUT1 and OUT2.
- 3) Pins 5, 11 and 12 of this product are N.C pins. Do not connect any wiring to these pins.

## STK681-332-E

(5) When mounting multiple drivers on a single PC board

When mounting multiple drivers on a single PC board, the GND design should mount a  $V_{CC}$  decoupling capacitor, C1, for each driver to stabilize the GND potential of the other drivers. The key wiring points are as follows.

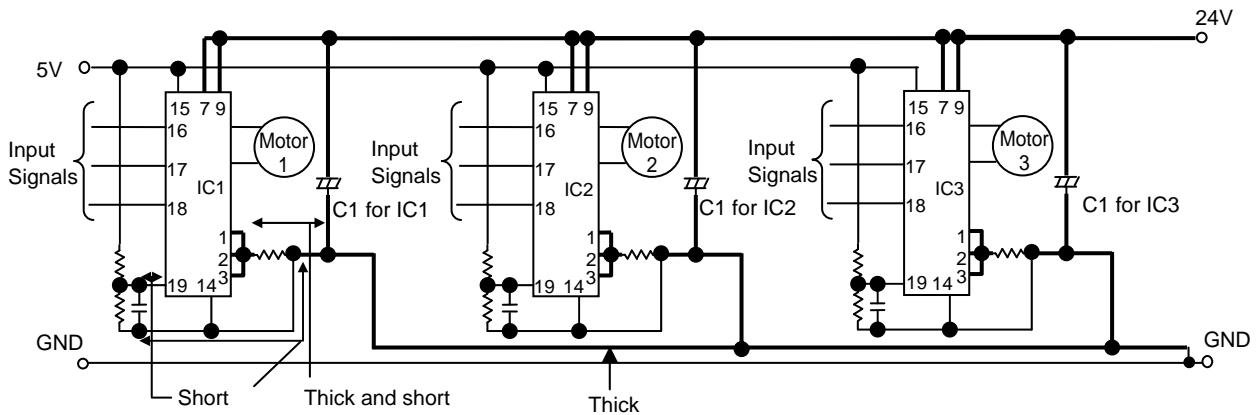

### ORDERING INFORMATION

Device	Package	Shipping (Qty / Packing)
STK681-332-E	SIP-19 (Pb-Free)	20 / Fan-Fold

ON Semiconductor and the ON logo are registered trademarks of Semiconductor Components Industries, LLC (SCILLC). SCILLC owns the rights to a number of patents, trademarks, copyrights, trade secrets, and other intellectual property. A listing of SCILLC's product/patent coverage may be accessed at [www.onsemi.com/site/pdf/Patent-Marking.pdf](http://www.onsemi.com/site/pdf/Patent-Marking.pdf). SCILLC reserves the right to make changes without further notice to any products herein. SCILLC makes no warranty, representation or guarantee regarding the suitability of its products for any particular purpose, nor does SCILLC assume any liability arising out of the application or use of any product or circuit, and specifically disclaims any and all liability, including without limitation special, consequential or incidental damages. "Typical" parameters which may be provided in SCILLC data sheets and/or specifications can and do vary in different applications and actual performance may vary over time. All operating parameters, including "Typicals" must be validated for each customer application by customer's technical experts. SCILLC does not convey any license under its patent rights nor the rights of others. SCILLC products are not designed, intended, or authorized for use as components in systems intended for surgical implant into the body, or other applications intended to support or sustain life, or for any other application in which the failure of the SCILLC product could create a situation where personal injury or death may occur. Should Buyer purchase or use SCILLC products for any such unintended or unauthorized application, Buyer shall indemnify and hold SCILLC and its officers, employees, subsidiaries, affiliates, and distributors harmless against all claims, costs, damages, and expenses, and reasonable attorney fees arising out of, directly or indirectly, any claim of personal injury or death associated with such unintended or unauthorized use, even if such claim alleges that SCILLC was negligent regarding the design or manufacture of the part. SCILLC is an Equal Opportunity/Affirmative Action Employer. This literature is subject to all applicable copyright laws and is not for resale in any manner.

# Mouser Electronics

Authorized Distributor

Click to View Pricing, Inventory, Delivery & Lifecycle Information:

[ON Semiconductor:](#)

[STK681-332-E](#)