

2 OUTPUT PCIE GEN1/2/3 SYNTHESIZER

5V41235

Recommended Applications

2 Output synthesizer for PCIe Gen1/2/3 and Ethernet

General Description

The 5V41235 is a PCIe Gen2/3 compliant spread spectrum capable clock generator. The device has 2 differential HCSL outputs and can be used in communication or embedded systems to substantially reduce electro-magnetic interference (EMI). The spread amount and output frequency are selectable via select pins. The 5V41235 can also supply 25 MHz, 125 MHz and 200 MHz outputs for applications such as Ethernet.

Output Features

- 2 - 0.7V current mode differential HCSL output pairs

Features/Benefits

- 16-pin TSSOP and QFN packages; small board footprint
- Spread-spectrum capable; reduces EMI
- Outputs can be terminated to LVDS; can drive a wider variety of devices
- TSSOP package: 25MHz, 100MHz, 125MHz and 200MHz output frequencies.
- QFN package: 100MHz and 200MHz output frequencies.
- OE control pin; greater system power management
- Spread% and frequency pin selection; no software required to configure device
- Industrial temperature range available; supports demanding embedded applications

Key Specifications

- Cycle-to-cycle jitter < 100 ps
- Output-to-output skew < 50 ps
- PCIe Gen2 phase jitter < 3.0ps RMS
- PCIe Gen3 phase jitter <1.0ps RMS

Block Diagram

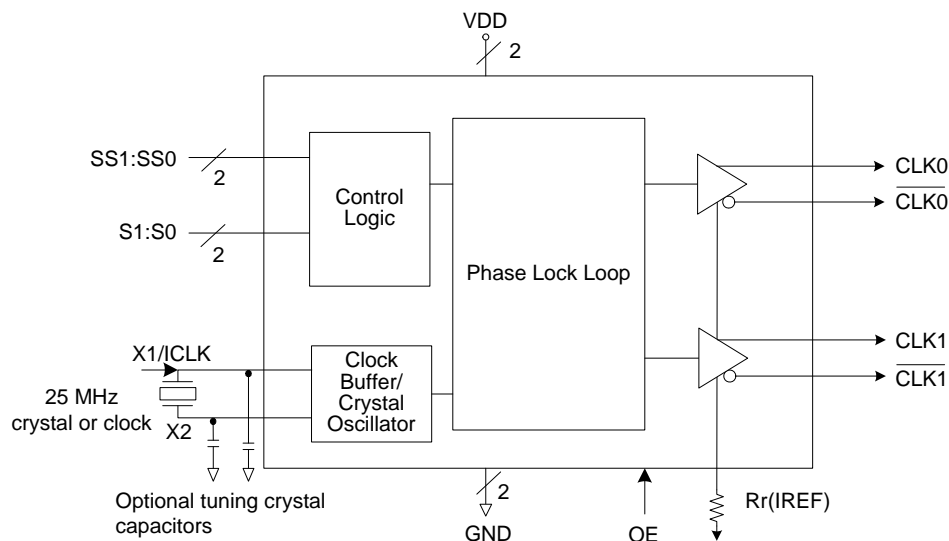

Pin Assignments

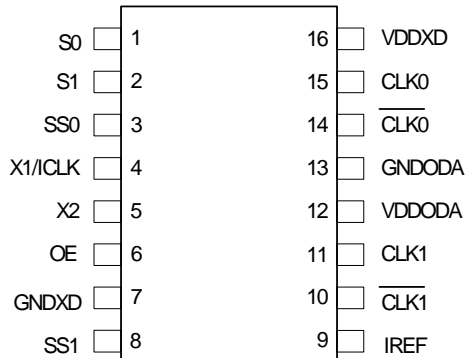

16-pin (173 mil) TSSOP

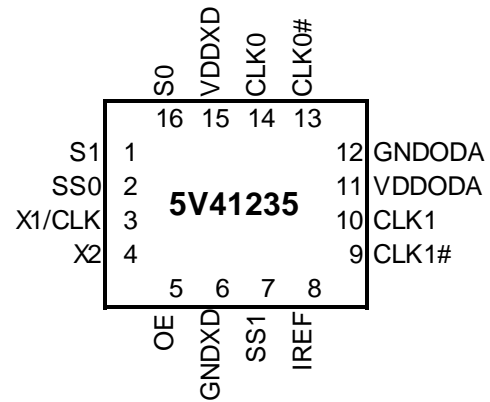

16-pin QFN

Output Select Table 1 (MHz) - TSSOP Only

S1	S0	CLK(1:0), $\overline{\text{CLK}}(1:0)$
0	0	25M
0	1	100M
1	0	125M
1	1	200M

Spread Selection Table 2 - TSSOP Only

SS1	SS0	Spread%
0	0	No Spread
0	1	Down -0.5
1	0	Down -0.75
1	1	No Spread

Output/Spread Select Table 3 - QFN Only

S1	S0	SS1	SS0	Output	Spread%
0	0	0	0	100MHz	-0.5
0	0	0	1	200MHz	-0.5
0	0	1	0	100MHz	No spread
0	0	1	1	Reserved	
0	1	0	0	100MHz	-1
0	1	0	1	200MHz	-1
0	1	1	0	Reserved	
0	1	1	1	Reserved	
1	0	0	0	100MHz	-1.5
1	0	0	1	200MHz	-1.5
1	0	1	0	Reserved	
1	0	1	1	Reserved	
1	1	0	0	Reserved	
1	1	0	1	200MHz	No spread
1	1	1	0	Reserved	
1	1	1	1	Reserved	

Pin Descriptions

QFN Pin Number	TSSOP Pin Number	Pin Name	Pin Type	Pin Description
16	1	S0	Input	Select pin 0. See Table1. Internal pull-up resistor.
1	2	S1	Input	Select pin 1. See Table 1. Internal pull-up resistor.
2	3	SS0	Input	Spread Select pin 0. See Table 2. Internal pull-up resistor.
3	4	X1/ICLK	Input	Crystal or clock input. Connect to a 25 MHz crystal or single ended clock.
4	5	X2	Output	Crystal connection. Leave unconnected for clock input.
5	6	OE	Input	Output enable. Tri-states outputs and device is not shut down. Internal pull-up resistor.
6	7	GNDXD	Power	Connect to ground.
7	8	SS1	Input	Spread Select pin 1. See Table 2. Internal pull-up resistor.
8	9	IREF	Output	Precision resistor attached to this pin is connected to the internal current reference.
9	10	CLK1	Output	HCSL complementary clock output 1.
10	11	CLK1	Output	HCSL true clock output 1.
11	12	VDDODA	Power	Connect to voltage supply +3.3 V for output driver and analog circuits
12	13	GNDODA	Power	Connect to ground.
13	14	CLK0	Output	HCSL complementary clock output 0.
14	15	CLK0	Output	HCSL true clock output 0.
15	16	VDDXD	Power	Connect to voltage supply +3.3 V for crystal oscillator and digital circuit.

Applications Information

External Components

A minimum number of external components are required for proper operation.

Decoupling Capacitors

Decoupling capacitors of 0.01 μF should be connected between each VDD pin and the ground plane, as close to the VDD pin as possible. Do not share ground vias between components. Route power from power source through the capacitor pad and then into ICS pin.

Crystal

A 25 MHz fundamental mode parallel resonant crystal should be used. This crystal must have less than 300 ppm of error across temperature in order for the 5V41235 to meet PCI Express specifications.

Crystal Capacitors

Crystal capacitors are connected from pins X1 to ground and X2 to ground to optimize the accuracy of the output frequency.

C_L = Crystal's load capacitance in pF

Crystal Capacitors (pF) = $(C_L - 7) * 2$

For example, for a crystal with a 8pF load cap, each external crystal cap would be 2pF $[(8-7)*2=2]$.

Current Source (Iref) Reference Resistor - R_R

If board target trace impedance (Z) is 50 Ω , then $R_R = 475\Omega$ (1%), providing IREF of 2.32 mA. The output current (I_{OH}) is equal to 6*IREF.

Output Termination

The PCI-Express differential clock outputs of the 5V41235 are open source drivers and require an external series resistor and a resistor to ground. These resistor values and their allowable locations are shown in detail in the **PCI-Express Layout Guidelines** section.

The 5V41235 can also be configured for LVDS compatible voltage levels. See the **LVDS Compatible Layout Guidelines** section.

Output Structures

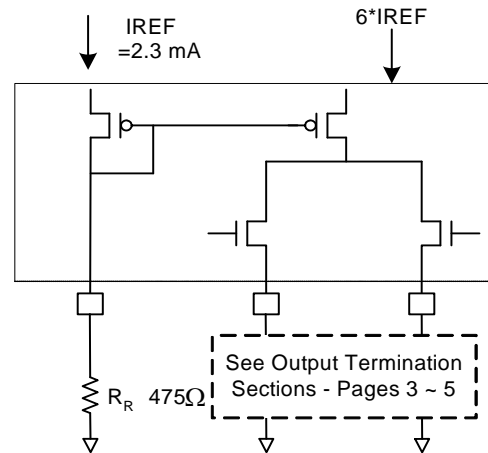

General PCB Layout Recommendations

For optimum device performance and lowest output phase noise, the following guidelines should be observed.

1. Each 0.01 μF decoupling capacitor should be mounted on the component side of the board as close to the VDD pin as possible.
2. No vias should be used between decoupling capacitor and VDD pin.
3. The PCB trace to VDD pin should be kept as short as possible, as should the PCB trace to the ground via. Distance of the ferrite bead and bulk decoupling from the device is less critical.
4. An optimum layout is one with all components on the same side of the board, minimizing vias through other signal layers (any ferrite beads and bulk decoupling capacitors can be mounted on the back). Other signal traces should be routed away from the 5V41235. This includes signal traces just underneath the device, or on layers adjacent to the ground plane layer used by the device.

Layout Guidelines

SRC Reference Clock			
Common Recommendations for Differential Routing	Dimension or Value	Unit	Figure
L1 length, route as non-coupled 50ohm trace	0.5 max	inch	1
L2 length, route as non-coupled 50ohm trace	0.2 max	inch	1
L3 length, route as non-coupled 50ohm trace	0.2 max	inch	1
R_s	33	ohm	1
R_t	49.9	ohm	1

Down Device Differential Routing			
L4 length, route as coupled microstrip 100ohm differential trace	2 min to 16 max	inch	1
L4 length, route as coupled stripline 100ohm differential trace	1.8 min to 14.4 max	inch	1

Differential Routing to PCI Express Connector			
L4 length, route as coupled microstrip 100ohm differential trace	0.25 to 14 max	inch	2
L4 length, route as coupled stripline 100ohm differential trace	0.225 min to 12.6 max	inch	2



Alternative Termination for LVDS and other Common Differential Signals (figure 3)

Vdiff	Vp-p	Vcm	R1	R2	R3	R4	Note
0.45v	0.22v	1.08	33	150	100	100	
0.58	0.28	0.6	33	78.7	137	100	
0.80	0.40	0.6	33	78.7	none	100	ICS874003i-02 input compatible
0.60	0.3	1.2	33	174	140	100	Standard LVDS

R1a = R1b = R1

R2a = R2b = R2



Cable Connected AC Coupled Application (figure 4)

Component	Value	Note
R5a, R5b	8.2K 5%	
R6a, R6b	1K 5%	
Cc	0.1 μF	
Vcm	0.350 volts	

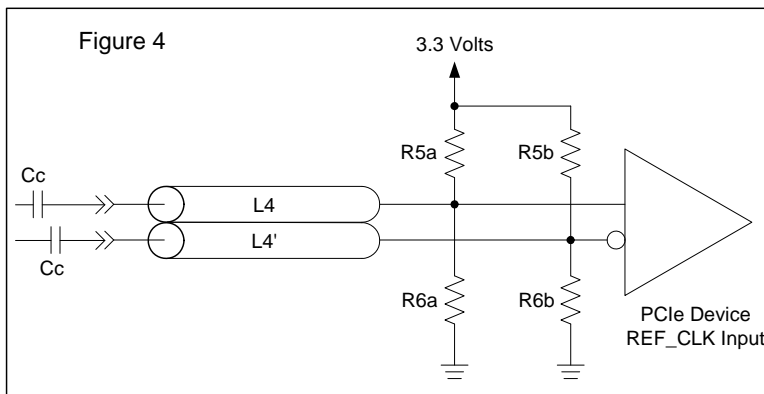

Typical PCI-Express (HCSL) Waveform

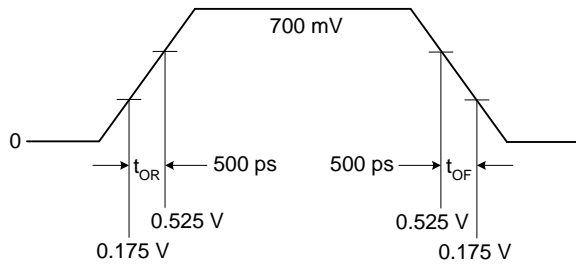

Typical LVDS Waveform

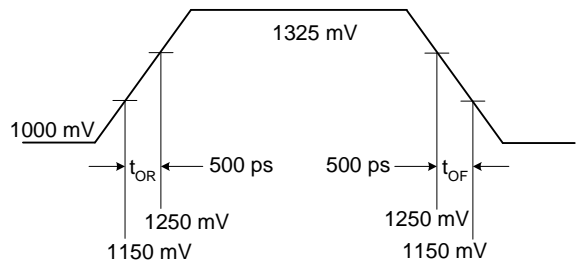

Absolute Maximum Ratings

Stresses above the ratings listed below can cause permanent damage to the 5V41235. These ratings are stress ratings only. Functional operation of the device at these or any other conditions above those indicated in the operational sections of the specifications is not implied. Exposure to absolute maximum rating conditions for extended periods can affect product reliability. Electrical parameters are guaranteed only over the recommended operating temperature range.

Item	Rating
Supply Voltage, VDDXD, VDDODA	4.6 V
All Inputs and Outputs	-0.5 V to VDD+0.5 V
Ambient Operating Temperature (commercial)	0 to +70°C
Ambient Operating Temperature (industrial)	-40 to +85°C
Storage Temperature	-65 to +150°C
Junction Temperature	125°C
Soldering Temperature	260°C
ESD Protection (Input)	2000 V min. (HBM)

DC Electrical Characteristics

Unless stated otherwise, VDD = 3.3 V \pm 5%, Ambient Temperature -40 to +85°C

Parameter	Symbol	Conditions	Min.	Typ.	Max.	Units
Supply Voltage	V		3.135	3.3	3.465	V
Input High Voltage ¹	V _{IH}	S0, S1, OE, ICLK, SS0, SS1	2.2		VDD +0.3	V
Input Low Voltage ¹	V _{IL}	S0, S1, OE, ICLK, SS0, SS1	VSS-0.3		0.8	V
Input Leakage Current ²	I _{IL}	0 < V _{in} < VDD	-5		5	μ A
Operating Supply Current @ 100 MHz	I _{DD}	R _S =33 Ω , R _P =50 Ω , C _L =2 pF		63	85	mA
	I _{DDOE}	OE =Low		42	50	mA
Input Capacitance	C _{IN}	Input pin capacitance			7	pF
Output Capacitance	C _{OUT}	Output pin capacitance			6	pF
X1, X2 Capacitance	C _{INX}				5	pF
Pin Inductance	L _{PIN}				5	nH
Output Impedance	Z _O	CLK outputs	3.0			k Ω
Pull-up Resistor	R _{PU}	S0, S1, OE, SS0, SS1		100		k Ω

1. Single edge is monotonic when transitioning through region.
2. Inputs with pull-ups/-downs are not included.

AC Electrical Characteristics - CLK0/CLK1, $\overline{\text{CLK0/CLK1}}$

Unless stated otherwise, VDD=3.3 V \pm 5%, Ambient Temperature -40 to +85°C

Parameter	Symbol	Conditions	Min.	Typ.	Max.	Units
Input Frequency				25		MHz
Output Frequency		HCSL termination	25		200	MHz
		LVDS termination	25		100	MHz
Output High Voltage ^{1,2}	V _{OH}	HCSL			850	mV
Output Low Voltage ^{1,2}	V _{OL}	HCSL	-150			mV
Crossing Point Voltage ^{1,2}		Absolute	250		550	mV
Crossing Point Voltage ^{1,2,4}		Variation over all edges			140	mV
Jitter, Cycle-to-Cycle ^{1,3}					100	ps
Frequency Synthesis Error		All outputs		0		ppm
Modulation Frequency		Spread spectrum	30	32.9	33	kHz
Rise Time ^{1,2}	t _{OR}	From 0.175 V to 0.525 V	175		700	ps
Fall Time ^{1,2}	t _{OF}	From 0.525 V to 0.175 V	175		700	ps
Rise/Fall Time Variation ^{1,2}					125	ps
Output to Output Skew					50	ps
Duty Cycle ^{1,3}			45		55	%
Output Enable Time ⁵		All outputs		50	100	ns
Output Disable Time ⁵		All outputs		50	100	ns
Stabilization Time	t _{STABLE}	From power-up VDD=3.3 V			1.8	ms
Spread Spectrum Transition Time	t _{SPREAD}	Stabilization time after spread spectrum changes	7		30	ms

Note 1: Test setup is R_S=33Ω, R_P=50Ω with C_L=2 pF, R_r = 475Ω (1%).

Note 2: Measurement taken from a single-ended waveform.

Note 3: Measurement taken from a differential waveform.

Note 4: Measured at the crossing point where instantaneous voltages of both CLK and $\overline{\text{CLK}}$ are equal.

Note 5: CLK pins are tri-stated when OE is low asserted. CLK is driven differential when OE is high.

Electrical Characteristics - Differential Phase Jitter Parameters

T_A = Commercial and Industrial, Supply Voltage VDD = 3.3 V \pm 5%

PARAMETER	Symbol	Conditions	SPEC				Notes
			Min	Typ	Max	Units	
Jitter, Phase	t _{jphaseG1}	PCIe Gen 1		28	86	ps (p-p)	1,2,3
	t _{jphaseG2Lo}	PCIe Gen 2 10kHz < f < 1.5MHz		0.7	3	ps (RMS)	1,2,3
	t _{jphaseG2High}	PCIe Gen 2 1.5MHz < f < Nyquist (50MHz)		1.8	3.1	ps (RMS)	1,2,3
	t _{jphaseG3}	PCIe Gen 3		0.48	1	ps (RMS)	1,2,3

¹Guaranteed by design and characterization, not 100% tested in production.

²See <http://www.pcisig.com> for complete specs

³Applies to 100MHz, spread off and 0.5% down spread only.

Thermal Characteristics (16TSSOP)

Parameter	Symbol	Conditions	Min.	Typ.	Max.	Units
Thermal Resistance Junction to Ambient	θ_{JA}	Still air		78		°C/W
	θ_{JA}	1 m/s air flow		70		°C/W
	θ_{JA}	3 m/s air flow		68		°C/W
Thermal Resistance Junction to Case	θ_{JC}			37		°C/W

Thermal Characteristics (16QFN)

Parameter	Symbol	Conditions	Min.	Typ.	Max.	Units
Thermal Resistance Junction to Ambient	θ_{JA}	Still air		63.2		°C/W
	θ_{JA}	1 m/s air flow		55.9		°C/W
	θ_{JA}	3 m/s air flow		51.4		°C/W
Thermal Resistance Junction to Case	θ_{JC}			65.8		°C/W

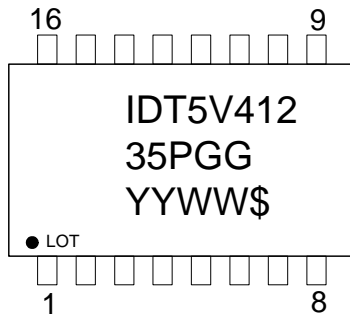
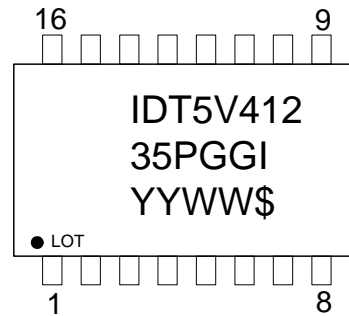
Marking Diagram (5V41235PGG)**Marking Diagram (5V41235PGGI)****Notes:**

1. Line 1 and 2: IDT part number.
2. Line 3: YYWW – Date code; \$ – Assembly location.
3. "G" after the two-letter package code designates RoHS compliant package.
4. "I" at the end of part number indicates industrial temperature range.
5. Bottom marking: country of origin if not USA.

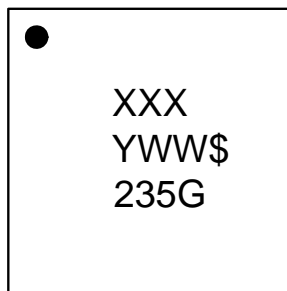
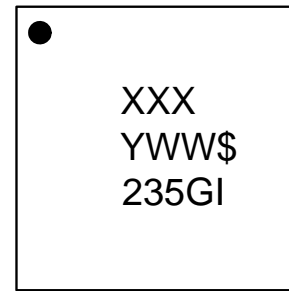
Marking Diagram (5V41235NLGI)**Marking Diagram (5V41235NLGI)****Notes:**

1. Line 1: Lot number.
2. Line 2: YWW – Date code; \$ – Assembly location.
3. "G" designates RoHS compliant package.
4. "I" at the end of part number indicates industrial temperature range.
5. Bottom marking: country of origin if not USA.

Package Outline and Package Dimensions (3 x 3 mm 16-QFN)

REVISIONS			
REV	DESCRIPTION	DATE	APPROVED
00	INITIAL RELEASE	10/15/08	RC
01	COMBINE POD & LAND PATTERN	9/17/13	KS

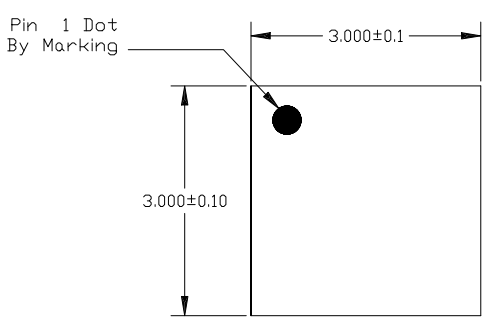

TOP VIEW

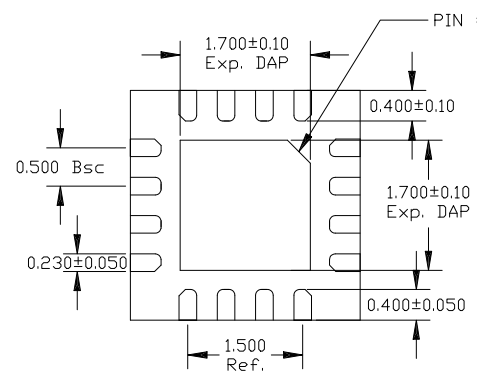

BOTTOM VIEW

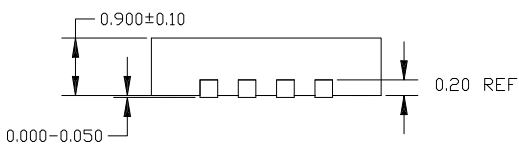

TOP VIEW

16LD QFN 3X3 (0.5MM PITCH)

TOLERANCES UNLESS SPECIFIED		6024 Silver Creek Valley Road San Jose, CA 95138 PHONE: (408) 284-8200 FAX: (408) 284-8591 www.IDT.com
DECIMAL	ANGULAR	
XX±	±	
XXX±		
APPROVALS	DATE	TITLE
DRAWN <i>BJC</i>	10/15/08	NL/NLG16 PACKAGE OUTLINE
CHECKED		3.0 x 3.0 mm BODY
		0.5 mm PITCH QFN
	SIZE	DRAWING No.
	C	PSC-4169
		REV
		01
DO NOT SCALE DRAWING		SHEET 1 OF 2

Package Outline and Package Dimensions (3 x 3 mm 16-QFN), cont.

REVISIONS			
REV	DESCRIPTION	DATE	APPROVED
00	INITIAL RELEASE	10/15/08	RC
01	COMBINE POD & LAND PATTERN	9/17/13	KS

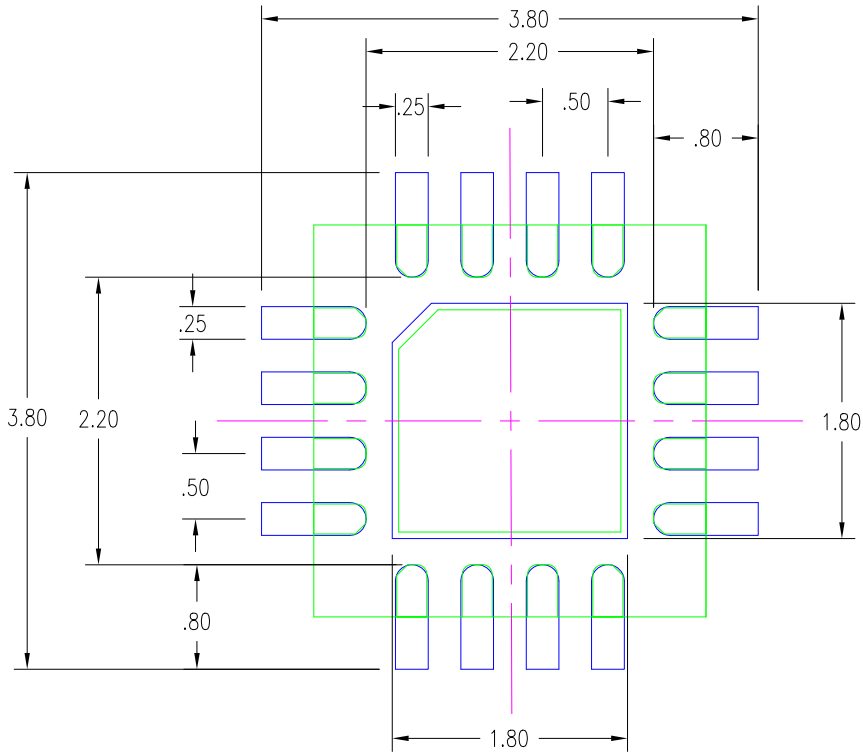

NOTES:

1. ALL DIMENSION ARE IN mm. ANGLES IN DEGREES.
2. TOP DOWN VIEW, AS VIEWED ON PCB.
3. COMPONENT OUTLINE SHOW FOR REFERENCE IN GREEN.
4. LAND PATTERN IN BLUE. NSMD PATTERN ASSUMED.
5. LAND PATTERN RECOMMENDATION PER IPC-7351B GENERIC REQUIREMENT FOR SURFACE MOUNT DESIGN AND LAND PATTERN.

TOLERANCES UNLESS SPECIFIED		 6024 Silver Creek Valley Road San Jose, CA 95138 PHONE: (408) 284-8200 FAX: (408) 284-8591 www.IDT.com		
DECIMAL	ANGULAR			
XX±	±			
XXX±		TITLE NL/NLG16 PACKAGE OUTLINE 3.0 x 3.0 mm BODY 0.5 mm PITCH QFN		
XXXX±				
APPROVALS	DATE	SIZE	DRAWING No.	REV
DRAWN <i>RC</i>	10/15/08	C	PSC-4169	01
CHECKED		DO NOT SCALE DRAWING		SHEET 2 OF 2

Package Outline and Package Dimensions (4.4 mm 16-TSSOP)

DATE		REVISIONS		
CREATED	REV	DESCRIPTION	AUTHOR	
08/25/98	02	ADD 14 & 16 LD	T. VU	
07/10/99	03	ADD 8 LD	T. VU	
5/23/01	04	ADDED TOPMARK TO TITLE		
10/14/04	05	ADD "GREEN" PGG NOMENCLATURE	TU VU	
3/8/13	06	ADDED PACKAGE CODE	RAC	
9/3/14	07	ADD TOLERANCE FOR A, A1, E AND b	CK LEE	
3/10/17	08	ADD OPTION T1	R.TANH	

NOTE: REFER TO DCP FOR OFFICIAL RELEASE DATE

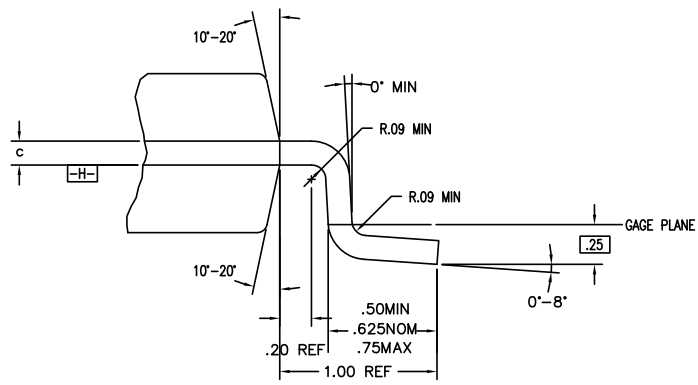
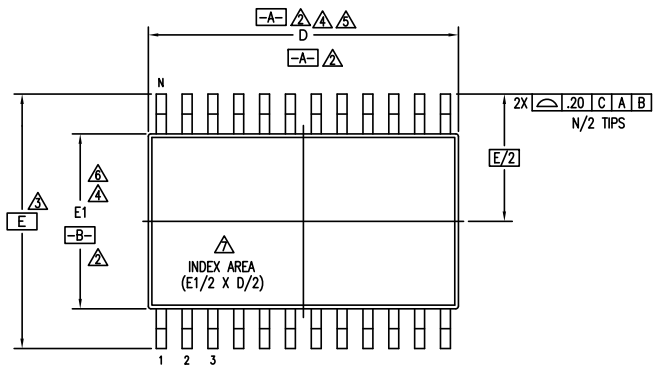

DETAIL B

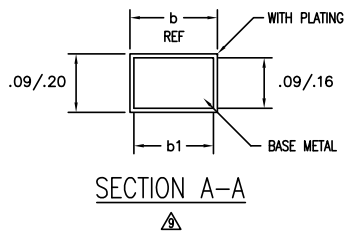
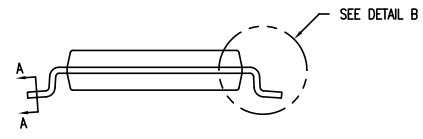
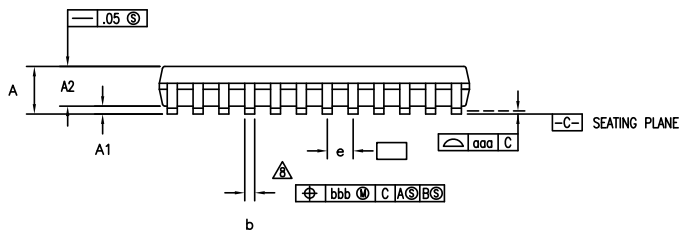

SECTION A-A

TOLERANCES UNLESS SPECIFIED DECIMAL ANGULAR XX± ± XXX± ± XXXX± ±		2975 Stender Way Santa Clara, CA 95054 PHONE: (408) 727-6116 FAX: (408) 492-8674
		www.IDT.com
TITLE PG/PGG PACKAGE OUTLINE (PG OR PA TOPMARK CODE) 4.4 mm BODY WIDTH TSSOP .65 mm PITCH		
SIZE C	DRAWING No. PSC-4056	REV 08
DO NOT SCALE DRAWING		SHEET 1 OF 3

Package Outline and Package Dimensions (4.4 mm 16-TSSOP), cont.

DATE CREATED		REVISIONS		
REV	DESCRIPTION	AUTHOR		
08/25/98	02	ADD 14 & 16 LD	T. VU	
07/10/99	03	ADD 8 LD	T. VU	
5/23/01	04	ADDED TOPMARK TO TITLE		
10/14/04	05	ADD "GREEN" PGG NOMENCLATURE	TU VU	
3/8/13	06	ADDED PACKAGE CODE	RAC	
9/3/14	07	ADD TOLERANCE FOR A, A1, E AND b	CK LEE	
3/10/17	08	ADD OPTION T1	R.TANH	

NOTE: REFER TO DCP FOR OFFICIAL RELEASE DATE

SYMBOL	PG/PGG8				NOTE	PG/PGG14				NOTE	PG/PGG16				NOTE	PG/PGG20				NOTE	PG/PGG24				NOTE	PG/PGG28				NOTE
	JEDEC VARIATION			AA		JEDEC VARIATION			AB-1		JEDEC VARIATION			AB		JEDEC VARIATION			AC		JEDEC VARIATION			AD		JEDEC VARIATION			AE	
	MIN	NOM	MAX			MIN	NOM	MAX			MIN	NOM	MAX			MIN	NOM	MAX			MIN	NOM	MAX			MIN	NOM	MAX		
A	.85	1.10	1.20			.85	1.10	1.20			.85	1.10	1.20			.85	1.10	1.20			.85	1.10	1.20			.85	1.10	1.20		
A1	.05	.10	.15			.05	.10	.15			.05	.10	.15			.05	.10	.15			.05	.10	.15			.05	.10	.15		
A2	.80	1.00	1.05			.80	1.00	1.05			.80	1.00	1.05			.80	1.00	1.05			.80	1.00	1.05			.80	1.00	1.05		
D	2.90	3.00	3.10	4,5		4.90	5.00	5.10	4,5		4.90	5.00	5.10	4,5		6.40	6.50	6.60	4,5		7.70	7.80	7.90	4,5		9.60	9.70	9.80	4,5	
E	6.20	6.40	6.60	3		6.20	6.40	6.60	3		6.20	6.40	6.60	3		6.20	6.40	6.60	3		6.20	6.40	6.60	3		6.20	6.40	6.60	3	
E1	4.30	4.40	4.50	4,6		4.30	4.40	4.50	4,6		4.30	4.40	4.50	4,6		4.30	4.40	4.50	4,6		4.30	4.40	4.50	4,6		4.30	4.40	4.50	4,6	
e	.65 BSC					.65 BSC					.65 BSC					.65 BSC					.65 BSC					.65 BSC				
b	.19	.25	.30			.19	.25	.30			.19	.25	.30			.19	.25	.30			.19	.25	.30			.19	.25	.30		
b1	.19	.22	.25			.19	.22	.25			.19	.22	.25			.19	.22	.25			.19	.22	.25			.19	.22	.25		
aaa	-	-	.10			-	-	.10			-	-	.10			-	-	.10			-	-	.10			-	-	.10		
bbb	-	-	.10			-	-	.10			-	-	.10			-	-	.10			-	-	.10			-	-	.10		
N	8					14					16					20					24					28				

NOTES:

- ALL DIMENSIONING AND TOLERANCING CONFORM TO ASME Y14.5M-1994
- DATUMS **-A-** AND **-B-** TO BE DETERMINED AT DATUM PLANE **-H-**
- DIMENSION E TO BE DETERMINED AT SEATING PLANE **-C-**
- DIMENSIONS D AND E1 ARE TO BE DETERMINED AT DATUM PLANE **-H-**
- DIMENSION D DOES NOT INCLUDE MOLD FLASH, PROTRUSIONS OR GATE BURRS. MOLD FLASH, PROTRUSIONS OR GATE BURRS SHALL NOT EXCEED .15 mm PER SIDE
- DIMENSION E1 DOES NOT INCLUDE INTERLEAD FLASH OR PROTRUSIONS. INTERLEAD FLASH OR PROTRUSIONS SHALL NOT EXCEED .25 mm PER SIDE
- DETAIL OF PIN 1 IDENTIFIER IS OPTIONAL BUT MUST BE LOCATED WITHIN THE ZONE INDICATED
- LEAD WIDTH DIMENSION DOES NOT INCLUDE DAMBAR PROTRUSION. ALLOWABLE DAMBAR PROTRUSION IS .08 mm IN EXCESS OF THE LEAD WIDTH DIMENSION AT MAXIMUM MATERIAL CONDITION. DAMBAR CANNOT BE LOCATED ON THE LOWER RADIUS OR THE FOOT
- THESE DIMENSIONS APPLY TO THE FLAT SECTION OF THE LEAD BETWEEN .10 AND .25 mm FROM THE LEAD TIP
- ALL DIMENSIONS ARE IN MILLIMETERS
- THIS OUTLINE CONFORMS TO JEDEC PUBLICATION 95 REGISTRATION MO-153, VARIATION AA, AB-1, AB, AC, AD & AE

SYMBOL	OPTION T1				NOTE
	PGG14T1				
	JEDEC VARIATION			AB-1	
MIN	NOM	MAX			
A	.90	1.10	1.20		
A1	.05	.10	.15		
A2	.80	1.00	1.05		
D	4.90	5.00	5.10	4,5	
E	6.20	6.40	6.60	3	
E1	4.30	4.40	4.50	4,6	
e	.65 BSC				
b	.19	.25	.30		
b1	.19	.22	.25		
c	.09	-	.20		
aaa	-	-	.10		
bbb	-	-	.10		
N	14				

TOLERANCES UNLESS SPECIFIED	 2975 Stender Way Santa Clara, CA 95054 PHONE: (408) 727-6116 FAX: (408) 492-8674
DECIMAL ±	
ANGULAR ±	www.IDT.com
XXX±	TITLE PG/PGG PACKAGE OUTLINE (PG OR PA TOPMARK CODE)
XXXX±	4.4 mm BODY WIDTH TSSOP .65 mm PITCH
XXXX±	SIZE C DRAWING No. PSC-4056 REV 08
	DO NOT SCALE DRAWING SHEET 2 OF 3

Package Outline and Package Dimensions (4.4 mm 16-TSSOP), cont.

DATE CREATED	REVISIONS		
	REV	DESCRIPTION	AUTHOR
08/25/98	02	ADD 14 & 16 LD	T. VU
07/10/99	03	ADD 8 LD	T. VU
5/23/01	04	ADDED TOPMARK TO TITLE	
10/14/04	05	ADD "GREEN" PGG NOMENCLATURE	TU VU
3/8/13	06	ADDED PACKAGE CODE	RAC
9/3/14	07	ADD TOLERANCE FOR A, A1, E AND b	CK LEE
3/10/17	08	ADD OPTION T1	R.TANH

NOTE: REFER TO DCP FOR OFFICIAL RELEASE DATE

LAND PATTERN DIMENSIONS

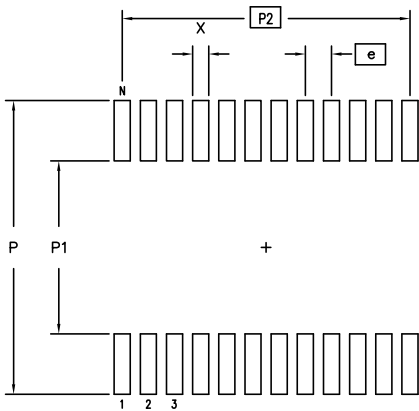

	MIN	MAX	MIN	MAX	MIN	MAX	MIN	MAX	MIN	MAX	MIN	MAX
P	7.20	7.40	7.20	7.40	7.20	7.40	7.20	7.40	7.20	7.40	7.20	7.40
P1	4.20	4.40	4.20	4.40	4.20	4.40	4.20	4.40	4.20	4.40	4.20	4.40
P2	1.95 BSC		3.90 BSC		4.55 BSC		5.85 BSC		7.15 BSC		8.45 BSC	
X	.30	.50	.30	.50	.30	.50	.30	.50	.30	.50	.30	.50
e	.65 BSC		.65 BSC		.65 BSC		.65 BSC		.65 BSC		.65 BSC	
N	8		14		16		20		24		28	

TOLERANCES
UNLESS SPECIFIED
DECIMAL ANGULAR
XX± ±
XXX± ±
XXXX± ±



2975 Stender Way
Santa Clara, CA 95054
PHONE: (408) 727-6116
FAX: (408) 492-8674

TITLE PG/PGG PACKAGE OUTLINE (PG OR PA TOPMARK CODE) 4.4 mm BODY WIDTH TSSOP .65 mm PITCH		
SIZE C	DRAWING No. PSC-4056	REV 08
DO NOT SCALE DRAWING		SHEET 3 OF 3

Ordering Information

Part / Order Number	Marking	Shipping Packaging	Package	Temperature
5V41235PGG	See Page 10	Tubes	16-pin TSSOP	0 to +70° C
5V41235PGG8		Tape and Reel	16-pin TSSOP	0 to +70° C
5V41235PGGI		Tubes	16-pin TSSOP	-40 to +85° C
5V41235PGGI8		Tape and Reel	16-pin TSSOP	-40 to +85° C
5V41235NLG	See Page 10	Tubes	16-pin QFN	0 to +70° C
5V41235NLG8		Tape and Reel	16-pin QFN	0 to +70° C
5V41235NLGI		Tubes	16-pin QFN	-40 to +85° C
5V41235NLGI8		Tape and Reel	16-pin QFN	-40 to +85° C

“G” after the two-letter package code are the Pb-Free configuration and are RoHS compliant.

While the information presented herein has been checked for both accuracy and reliability, Integrated Device Technology (IDT) assumes no responsibility for either its use or for the infringement of any patents or other rights of third parties, which would result from its use. No other circuits, patents, or licenses are implied. This product is intended for use in normal commercial applications. Any other applications such as those requiring extended temperature range, high reliability, or other extraordinary environmental requirements are not recommended without additional processing by IDT. IDT reserves the right to change any circuitry or specifications without notice. IDT does not authorize or warrant any IDT product for use in life support devices or critical medical instruments.

Revision History

Rev.	Originator	Date	Description of Change
A	RDW	11/02/11	Initial release.
B	RDW	11/22/11	1. Changed title to “2 Output PCIe GEN1/2/3 Synthesizer” 2. Updated Differential Phase Jitter table.
C	RDW	06/06/12	1. Updated Features bullet(s) from: “• 25 MHz, 125 MHz and 200 MHz output frequencies; supports Ethernet applications”, to: “• 25 MHz, 100MHz, 125 MHz and 200 MHz output frequencies; TSSOP-only • 100MHz output frequency; MLF package”. 2. Added table 3, Output/Spread Select table for MLF only
D	S. Sharma	10/16/12	1. Updated and expanded Output Select table per char review. 2. Changed crystal capacitance load spec from 16pF to 8pF.
E	IH	09/09/15	Corrected typo in Ordering information; NLG and NLGI shipping packaging changed from “Tray” to “Tubes”.
F	IH	07/08/16	Updated marking diagrams for TSSOP devices.
G	RDW	10/11/16	1. Updated Features bullets for package output frequencies. 2. Changed all MLF references to QFN.
H	B. Shen	01/12/17	Updated 16QFN POD drawing to latest showing chamfered epad.
J	C.P.	05/05/17	Updated PGG16 package outline drawing to latest version.

5V41235

2 OUTPUT PCIE GEN1/2/3 SYNTHESIZER

Innovate with IDT and accelerate your future networks. Contact:

www.IDT.com

For Sales

800-345-7015 or 408-284-8200

Fax: 408-284-2775

www.idt.com/go/sales

For Tech Support

www.idt.com/go/support

Corporate Headquarters

Integrated Device Technology, Inc.

www.idt.com



DISCLAIMER Integrated Device Technology, Inc. (IDT) and its affiliated companies (herein referred to as "IDT") reserve the right to modify the products and/or specifications described herein at any time, without notice, at IDT's sole discretion. Performance specifications and operating parameters of the described products are determined in an independent state and are not guaranteed to perform the same way when installed in customer products. The information contained herein is provided without representation or warranty of any kind, whether express or implied, including, but not limited to, the suitability of IDT's products for any particular purpose, an implied warranty of merchantability, or non-infringement of the intellectual property rights of others. This document is presented only as a guide and does not convey any license under intellectual property rights of IDT or any third parties.

IDT's products are not intended for use in applications involving extreme environmental conditions or in life support systems or similar devices where the failure or malfunction of an IDT product can be reasonably expected to significantly affect the health or safety of users. Anyone using an IDT product in such a manner does so at their own risk, absent an express, written agreement by IDT.

Integrated Device Technology, IDT and the IDT logo are trademarks or registered trademarks of IDT and its subsidiaries in the United States and other countries. Other trademarks used herein are the property of IDT or their respective third party owners. For datasheet type definitions and a glossary of common terms, visit www.idt.com/go/glossary. Integrated Device Technology, Inc.. All rights reserved.

Mouser Electronics

Authorized Distributor

Click to View Pricing, Inventory, Delivery & Lifecycle Information:

[IDT \(Integrated Device Technology\):](#)

[5V41235PGGI](#) [5V41235NLGI8](#) [5V41235PGG](#) [5V41235NLG](#) [5V41235PGG8](#) [5V41235PGGI8](#) [5V41235NLGI](#)
[5V41235NLG8](#)