



MachXO2 Dual Sensor Interface Board

User's Guide

Introduction

Building off Lattice's broad support for bridging image sensors to parallel buses for ISP (Image Signal Processors), Lattice has designed a new sensor interface board. There are two purposes for the MachXO2™ Dual Sensor Interface Board (DSIB). First, the DSIB confirms that sensor bridges can be implemented in the low cost MachXO2 device. Second, the DSIB platform demonstrates two image sensors being merged into one parallel stream for an ISP to process the combined image.

The DSIB is designed to provide users with a platform to support dual sensor designs such as 3D stereoscopic video, black box car driver recorders and other applications that require more than one sensor. The DSIB is used in conjunction with the HDR-60 Base Board and two 9MT024 Aptina 720p NanoVesta boards (see Figure 1). See EB59, [HDR-60 Development Kit User's Guide](#) and EB63, [NanoVesta Head Board User's Guide](#) for further information on these boards.

Figure 1. MachXO2 Dual Sensor Interface Board with Dual Sensors

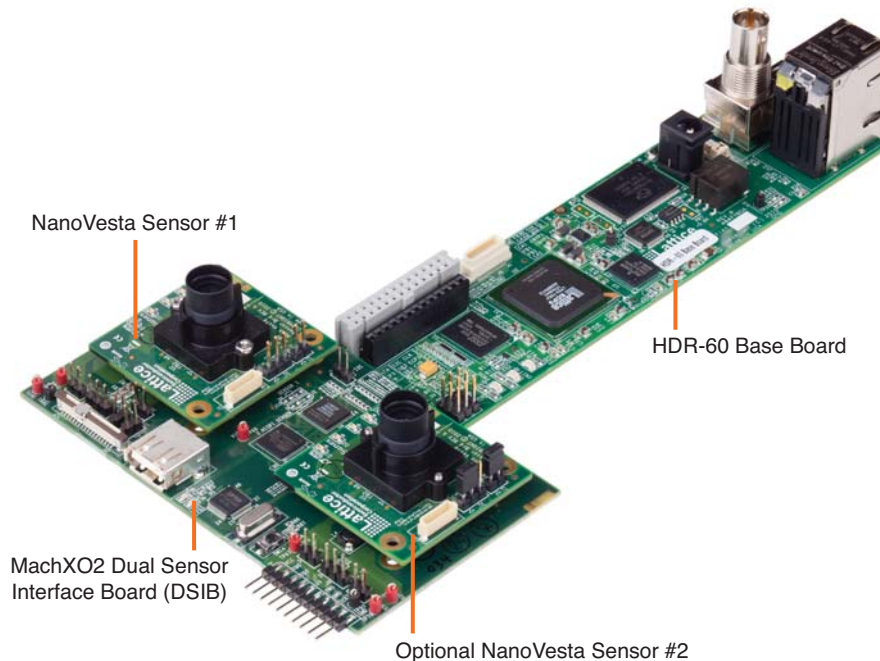

Some common applications and uses for the MachXO2 Dual Sensor Interface Board include:

- 3D stereoscopic video cameras
- Aftermarket automotive black box DVR
- 3D camera for analytics in security/surveillance applications
- Traffic cameras where one sensor records video and the other sensor takes the photo
- Interfacing to the Texas Instruments (TI) IPNC DM812x, DM385 or DM385 camera base boards
- Evaluation of MachXO2 device interfacing to sub-LVDS signals
- Sensor bridges using a MachXO2 device to convert from serial sensors to parallel buses

Features

- MachXO2-4000 PLD for sensor interfacing and driving a parallel ISP bus
- LP SDRAM: 16-bit data over a 32Mb address space
- Built-in USB 2.0 download to MachXO2
- Can be configured for a flywire ispDOWNLOAD[®] cable connection
- HiSPi and other serial sensor interfaces can be supported
- One MEMS-based oscillator for sensor synchronization
- 36-pin flat ribbon cable connector for TI IPNC camera connections
- 3.3V, 2.5V and 1.8V voltages are possible for various MachXO2 I/O banks
- ispVM[™] System programming support

The MachXO2 Dual Sensor Interface Board demonstrates a low cost solution for combining data from two image sensors to a single ISP parallel bus. A MachXO2-4000 device and an external SDRAM memory device are the key components of the solution. The two Aptina sensors are configured to output pixel data via HiSPi serial data lanes. These HiSPi lanes are sent to the MachXO2 device where it converts the serial data of each sensor to two internal buses. Finally, the MachXO2 device combines the two sensors' data and outputs a single parallel bus. Depending on the desired output format, the external SDRAM device may be used by the MachXO2 device to store image frames and aid in output formatting. The parallel bus is typically driven to an ISP device (see Figure 2). However, when the DSIB is used with the HDR-60 Base Board, the output is sent to the LatticeECP3[™] FPGA which simply accepts the parallel bus and drives the HDMI connector so an image can be seen on a LCD monitor.

Figure 2. Dual Sensor HiSPi Bridge

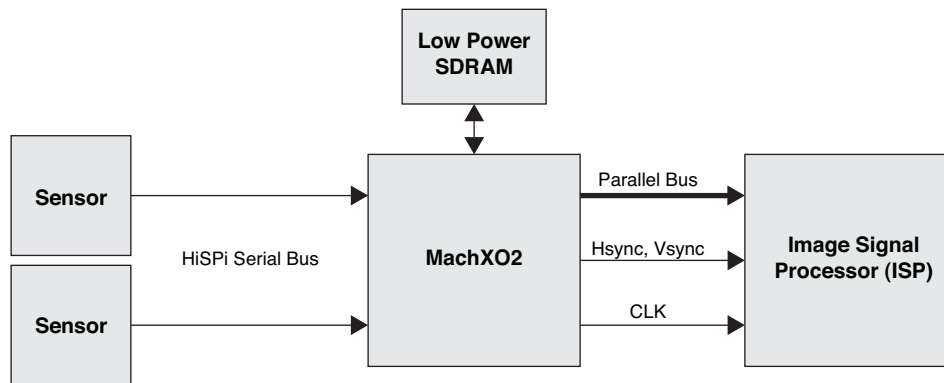

General Description

The heart of the MachXO2 Dual Sensor Interface Board is the MachXO2-4000 PLD. The devices and connectors attached to the MachXO2 device provide the means to investigate applications for sensor bridging and dual sensor processing. The board also provides several different interconnects to support many devices for a variety of purposes. The HiSPi or other serial sensor input, low power SDRAM memory and connectors for the parallel data are useful in applications that use Lattice sensor-oriented reference designs. To find resources such as updates to this document, sample applications and links to demos, visit the [Dual HiSPi Sensor Interface Bridge](#) page of the Lattice website and navigate to the appropriate page for this board.

Initial Setup and Handling

The following is recommended reading prior to removing the evaluation board from the static shielding bag and may or may not apply to your particular use of the board.

CAUTION: The devices on the board can be damaged by improper handling.

The devices on the MachXO2 Dual Sensor Interface Board contain fairly robust ESD (Electro Static Discharge) protection structures within them, able to withstand typical static discharges (see the “Human Body Model” specification for an example of ESD characterization requirements). Even so, the devices are static sensitive to conditions that exceed their designed-in protection. For example: higher static voltages, as well as lower voltages with lower series resistance or larger capacitance than the respective ESD specifications can potentially damage or degrade the devices on the evaluation board.

It is recommended that you wear an approved and functioning grounded wrist strap at all times while handling the evaluation board when it is removed from the static shielding bag. If you will not be using the board for an extended period of time, it is best to store it in the static shielding bag. Please save the static shielding bag and packing box for future storage of the board when it is not in use.

Before connecting the DSIB to the HDR-60 Base Board, attach a cable from chassis ground on grounded test equipment to GND on the board. Connecting the board ground to test equipment chassis ground will decrease the risk of ESD damage to the I/O on the board as the initial connections to the board are made. Likewise, when unplugging cables from the evaluation board, the last connection unplugged, should be the chassis GND connection to the evaluation board GND. If you have a signal source that is floating with respect to chassis GND, attempt to neutralize any static charge on that signal source prior to attaching it to the evaluation board.

If you are holding or carrying the board when it is not in a static shielding bag, keep your finger on the corners of the board. This will keep the board at the same voltage potential as your body until you can put the board back in the static shielding bag.

Electrical, Mechanical, and Environmental Specifications

The nominal board dimensions are 113 mm x 65 mm (4.4375” x 2.5625”). The environmental specifications are as follows:

- Operating temperature: 0°C to 55°C
- Storage temperature: -40°C to 75°C
- Humidity: <95% without condensation
- 5V DC power

Functional Description

Figure 3. MachXO2 Dual Sensor Interface Board, Top Side

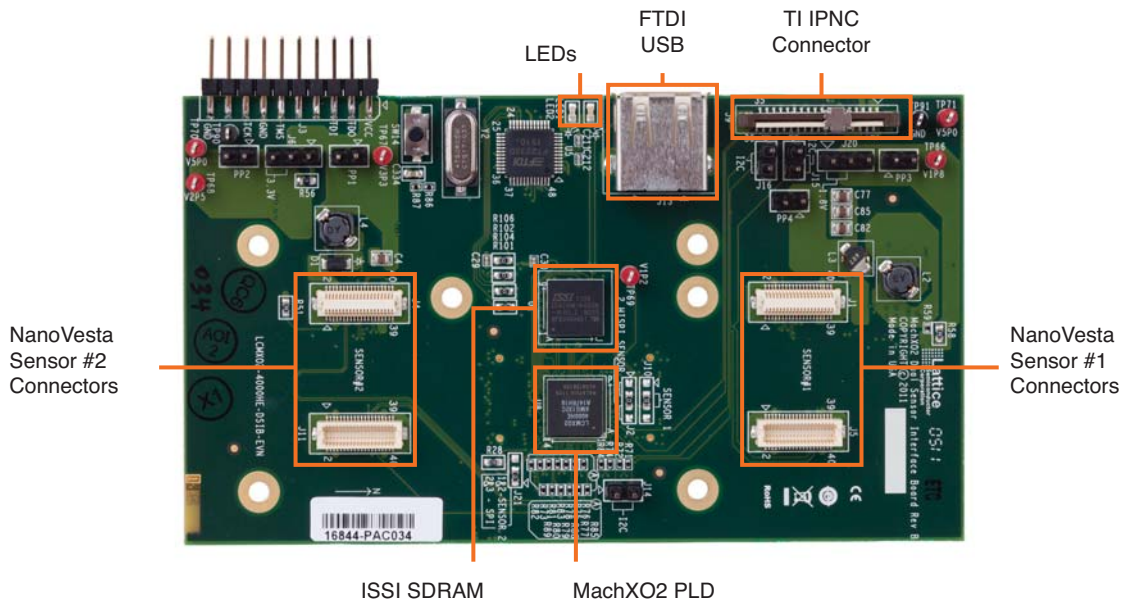

Configuration Options

There are several possible configurations that the MachXO2 Dual Sensor Interface Board can support. The options are described below.

Default Configuration

The DSIB is shipped in a state that allows support for only one image sensor, located in sensor #1 as marked on the board. The only jumper on the DSIB is J20 which shorts pins 1 and 2. This ensures that 1.8V is sourced to the SDRAM device. The default programming file in the MachXO2 device supports bridging an Aptina 9MT024 NanoVesta board plugged into location #1. It is also possible to plug a Panasonic MN34041 NanoVesta board or an Aptina AR0331 NanoVesta board into sensor location #1. However, for either of these sensors, the MachXO2 device will need to be reprogrammed.

The configuration options described below require the user to make some modifications and changes to the MachXO2 Dual Sensor Interface Board. Use caution when making any of these changes.

Dual Image Sensor HiSPi Configuration

The MachXO2 Dual Sensor Interface Board supports two image sensors that can be merged to form one image. The two sensors are the 9MT024 NanoVesta boards. To support the dual sensor HiSPi format, the following modifications need to be made. In locations J2 and J10, zero ohm resistors tie pins 2 and 3 together. Both resistors should be removed. Once this is complete, on both J2 and J10, pins 1 and 2 should be shorted and pins 3 and 4 should be shorted. Inserting zero ohm resistors is the recommended method to do this. Once these changes are made and two 9MT024 NanoVesta boards are inserted, then the MachXO2 needs to be reprogrammed. See the [Configuring/Programming the DSIB](#) section of this document for further details.

On both 9MT024 NanoVesta boards, it is important to ensure that jumper J2 has a jumper to short pins 2 and 3. This J2 jumper ensures that the same clock is driven to both sensors. No other jumpers should be on the 9MT024 NanoVesta board.

Lastly, note that when the dual image sensor HiSPi configuration is made to the DSIB, no Panasonic MN34041 sensor can be supported. Neither sensor location can accept a Panasonic MN34041 NanoVesta board. To support

a Panasonic MN34041 NanoVesta board, revert the board to the default configuration on the DSIB and plug the Panasonic board into sensor location #1.

I²C Sensor Bypass Configuration

Jumpers J14, J15 and J16 can be used for the LatticeECP3 device on the HDR-60 Base Board to configure the sensor in location #1. No demo code is available to support this programming, but inserting these jumpers allows the option to bypass the MachXO2 device for I²C programming of sensor location #1 only. The bypass does not support sensor #2. The default configuration does not have these jumpers set.

MachXO2 I²C Embedded Function Block Configuration

The last possible configuration is one that allows a user to access the hard I²C logic resident in the MachXO2 device. This built-in I²C function is in the Embedded Function Block of the MachXO2 device. The default configuration on the DSIB has J21 pins 1 and 2 shorted with a zero ohm resistor. For I²C Embedded Function Block support, the resistor between pins 1 and 2 on J21 must be removed. Then pins 2 and 3 must be shorted on J21 with a zero ohm resistor. Note that when the board is modified for I²C support, sensor location #2 is not supported.

MachXO2 Device

This board features a MachXO2-4000 FPGA with a 1.2V DC core in a 132-ball csBGA package. The MachXO2-1200, -2000 and -4000 device densities in this package can be accommodated with no change in pin connections, although some features are not supported in the smaller density devices. A complete description of this device can be found in the [MachXO2 Family Data Sheet](#).

Power Connections

The board is supplied 5V power from the HDR-60 Base Board connectors, J7 and J8. To power the DISB, a 5V supply can be applied to TP70 (+5V) and TP90 (GND). On-board step-down switching regulators then provide the necessary supply voltages: 3.3V, 2.5V, 1.8V and 1.2V.

The on-board switching regulator output voltages can be measured at test points located around the board as shown in Table 1.

Table 1. Test Points for On-Board Regulator Voltages

| Supply | Switching Regulator | Test Point | Feedback Resistors | Comment |
|--------|---------------------|------------|--------------------|--|
| 3.3V | U10 (side 2) | TP67 | R46, R45 | |
| 2.5V | U10 (side 1) | TP68 | R53, R5, R56, R51 | 1.8V: jumper on J6 pins 1-2 2.5V: no jumper on J4 (default) 3.3V: jumper on J6 pins 2-3 |
| 1.8V | U11 (side 2) | TP66 | R57, R58, R59, R6 | 1.8V: jumper on J20 pins 1-2 (default) 2.5V: no jumper on J20 3.3V: jumper on J20 pins 2-3 |
| 1.2V | U11 (side 1) | TP69 | R54, R52 | |

Each of the step-down switching regulators, U10 and U11, incorporate typical resistor divider voltage feedback to divide-down the regulator output voltage and compare it against an internal reference voltage. The regulator then adjusts the output voltage higher or lower such that the resistor divided voltage matches the internal reference. By doing this, the regulator output voltage remains at a constant voltage value independent of the load driven. The regulator output voltages are set by the ratio of the feedback resistor values shown in Table 1, multiplied by the regulator internal reference voltage. See the LT3508 device data sheets for additional details about these devices.

The 2.5V regulator output voltage can also be set to 1.8V or 3.3V by adding a shorting jumper on J6, as shown in Table 1. With no jumper on J6, the voltage divider is set by R53 and R5 and this divider sets up a nominal 2.5V output voltage. When a shorting jumper is added to J6, the R56 and R51 resistors will be placed in parallel with either R53 or R5, which then changes the resistor divider ratio, and this changes side 1 of the U10 regulator output volt-

age to become 1.8V or 3.3V, depending on the placement of the shorting jumper on J6. A similar configuration is supported for U11 side 2.

MachXO2 I/O Bank Voltages

Most of the bank voltages on the MachXO2 device (U8) have been hard-wired to selectable power supply values. Banks 0, 2 and 5 are normally 2.5V, but they can be modified by the location of J6. These banks interface to the parallel ISP bus and the sensor configuration pins. Banks 1, 3 and 4 are normally 1.8V, but they can be modified by the location of J20. These I/Os interface to the low power SDRAM memory, as shown in Table 2.

Table 2. MachXO2 (U8) Bank Voltage Settings

| MachXO2 Bank VCCIO | Voltage | Comment |
|--------------------|---------------|--|
| 0, 2 and 5 | 2.5V Normally | Parallel ISP bus, sensor configuration I/O, JTAG interface |
| 1, 3 and 4 | 1.8V Normally | Interface for the low power SDRAM |

Crystal Oscillators

There is one crystal oscillator and one MEMS-based oscillator on the MachXO2 Dual Sensor Interface Board (Table 3). The crystal oscillator is used for the USB port connection. The MEMS-based oscillator is 27 MHz and is delivered to the MachXO2 device as a design reference clock to provide a clock to the sensors, if desired.

Table 3. Crystal Oscillators Used on the HDR-60 Base Board

| Device | Board Location | Frequency | Comment | MachXO2 Input I/O Setting |
|-----------------------|----------------|-----------|---|---------------------------|
| MEMS-Based Oscillator | Y1 | 27 MHz | Used for sensor clock and to drive PLL in MachXO2 for low power SDRAM | Normally 2.5V |
| Crystal Oscillator | Y2 | 6 MHz | USB FTD2232D U5 pin 43 | — |

Image Sensor Connectors

The board has six Hirose connectors, configured as three pairs. These are located at J1 and J5, J4 and J11, and J7 and J8. The J1 and J5 pair are for sensor #1. The J4 and J11 pair are for sensor #2. The J7 and J8 pair allow the DSIB to plug into the HDR-60 Base Board.

HiSPi Connector for Sensor #1 (J1)

Bank 2 of the MachXO2 device can receive HiSPi sub-LVDS video signals from connector J1. This connector can also receive serial signals from the Panasonic MN34041. When receiving serial signals, set the MachXO2 input type to LVDS with differential 100 ohm termination. The signal connections between the MachXO2 device and the HiSPi connector are shown in Table 4.

Table 4. MachXO2 (U8) Interface to HiSPi Connector (J1)

| J1 Pin | MachXO2 I/O BGA Ball | Polarity | sysIO™ Bank | Differential Signal | Comment |
|--------|----------------------|----------|-------------|---------------------|---|
| 13 | M11 | P | 2 | SLVS_0P | — |
| 11 | P12 | N | 2 | SLVS_0N | — |
| 29 | P8 | P | 2 | SLVS_1P | — |
| 27 | M8 | N | 2 | SLVS_1N | — |
| 21 | P2 | P | 2 | SLVS_2P | — |
| 19 | N2 | N | 2 | SLVS_2N | — |
| 26 | M7 / P7 | P | 2 | SLVS_3P | Default for single sensor/dual sensor configuration |
| 24 | N8 / N7 | N | 2 | SLVS_3N | Default for single sensor/dual sensor configuration |
| 17 | N3 | P | 2 | PAN_B1P | Used for MN34041 |
| 15 | P4 | N | 2 | PAN_B1N | Used for MN34041 |
| 22 | M9 | P | 2 | PAN_B0P | Used for MN34041 |

Table 4. MachXO2 (U8) Interface to HiSPi Connector (J1) (Continued)

| J1 Pin | MachXO2 I/O BGA Ball | Polarity | sysIO™ Bank | Differential Signal | Comment |
|--------|----------------------|----------|-------------|---------------------|------------------|
| 20 | N10 | N | 2 | PAN_B0N | Used for MN34041 |
| 18 | N6 | P | 2 | SLVS_CP | — |
| 16 | P6 | N | 2 | SLVS_CN | — |

Parallel Connector for Sensor #1 (J5)

The MachXO2 (U8) Bank 5 receives sensor control signals for sensor #1 from the parallel connector J5. The signal connections between the MachXO2 device and the J5 connector are shown in Table 5.

Table 5. MachXO2 (U8) Interface to Parallel Connector J5

| J5 Pin | MachXO2 I/O BGA Ball | sysIO Bank | Parallel Signal | Differential Signal |
|--------|----------------------|------------|-----------------|---------------------|
| 9 | C2 | 5 | EXTCLK_FPGA | — |
| 25 | N4 | 2 | TRIGGER | — |
| 27 | F2 | 5 | RESET_BAR | — |
| 29 | C3 | 5 | OUTPUT_EN_BAR | — |
| 31 | D1 | 5 | STANDBY | — |
| 26 | B1 | 5 | SADDR | — |
| 28 | M4 | 2 | SCLK | — |
| 30 | P13 | 2 | SDATA | — |

HiSPi Connector for Sensor #2 (J4)

The MachXO2 Bank 2 can also receive HiSPi sub-LVDS video signals from connector J4. It is possible to receive other serial sensors from this sensor 2 location, but dual Panasonic MN34041 sensors are not supported. MN34041 only works in sensor location #1. When receiving serial signals, set the MachXO2 input type to LVDS with differential 100 ohm termination. The signal connections between the MachXO2 device and the HiSPi connector are shown in Table 6.

Table 6. MachXO2 (U8) Interface to HiSPi Connector J4

| J4 Pin | MachXO2 I/O BGA Ball | Polarity | sysIO Bank | Differential Signal | Comment |
|--------|----------------------|----------|------------|---------------------|-------------------------------|
| 13 | P3 | P | 2 | SLVS_0P | — |
| 11 | M3 | N | 2 | SLVS_0N | — |
| 29 | M10 | P | 2 | SLVS_1P | — |
| 27 | P11 | N | 2 | SLVS_1N | — |
| 21 | N5 | P | 2 | SLVS_2P | — |
| 19 | M5 | N | 2 | SLVS_2N | — |
| 26 | P9 | P | 2 | SLVS_3P | — |
| 24 | N9 | N | 2 | SLVS_3N | — |
| 18 | M7 | P | 2 | SLVS_CP | Configuration for dual sensor |
| 16 | N8 | N | 2 | SLVS_CN | Configuration for dual sensor |

Parallel Connector for Sensor #2 (J11)

The MachXO2 (U8) receives sensor control signals for sensor #2 from the parallel connector J11. The signal connections between the MachXO2 device and the J11 connector are shown in Table 7. Note that some of the control signals are connected to sensor #1 J5 also.

Table 7. MachXO2 (U8) Interface to Parallel Connector J11

| J11 Pin | MachXO2 I/O BGA Ball | sysIO Bank | Parallel Signal | Differential Signal |
|---------|----------------------|------------|-----------------|---------------------|
| 9 | C2 | 5 | EXTCLK_FPGA | — |
| 25 | N4 | 2 | TRIGGER | — |
| 27 | F2 | 5 | RESET_BAR | — |
| 29 | C3 | 5 | OUTPUT_EN_BAR | — |
| 31 | D1 | 5 | STANDBY | — |
| 26 | E1 | 5 | SADDR | — |
| 28 | E2 | 5 | SCLK | — |
| 30 | E3 | 5 | SDATA | — |

Parallel Connector to ISP Parallel Bus (J7)

The MachXO2 (U8) bank 0 sends parallel CMOS signals to the ISP. The parallel bus of the ISP drives both this connector J7 and the TI connector J9. The signal connections between the MachXO2 device and the J7 connector are shown in Table 8. Connections to the TI ISP connector J9 have the same MachXO2 pins as in Table 8. It is assumed that either the HDR-60 Base Board or the TI ISP connector J9 will receive the ISP parallel bus signal J7.

Table 8. MachXO2 (U8) Interface to Parallel ISP Connector J7

| J7 Pin | MachXO2 I/O BGA Ball | sysIO Bank | Parallel Signal | Differential Signal |
|--------|----------------------|------------|-----------------|------------------------------------|
| 10 | A11 | 0 | PIXCLK | |
| 11 | C4 | 0 | LINE VALID | |
| 12 | B7 | 0 | FRAME VALID | |
| 13 | A9 | 0 | D6 | |
| 14 | A7 | 0 | D4 | |
| 15 | C11 | 0 | D2 | |
| 16 | C6 | 0 | D0 | |
| 17 | A10 | 0 | D7 | |
| 18 | B5 | 0 | D5 | |
| 19 | A12 | 0 | D3 | |
| 20 | B3 | 0 | D1 | |
| 21 | C12 | 0 | D10 | |
| 22 | A2 | 0 | D8 | |
| 23 | B13 | 0 | D11 | |
| 24 | B12 | 0 | D9 | |
| 26 | A3 | 0 | SADDR | Only for LatticeECP3 communication |
| 27 | B9 | 0 | D12 | Only for LatticeECP3 communication |
| 28 | C9 | 0 | SCLK | Only for LatticeECP3 communication |
| 29 | A13 | 0 | D13 | Optional |
| 30 | C10 | 0 | SDATA | Only for LatticeECP3 communication |

Downloading Bitstreams into the MachXO2 (U8)

In order to download bitstreams into the MachXO2 device, a USB-A to USB-A cable can connect a PC (with Lattice Diamond® design software installed) to the MachXO2 Dual Sensor Interface Board. Each USB-A to USB-A cable is

6 feet (1.83 meters) in length. Connector J13 is the USB port. A FTD2232D USB transceiver (U5) translates the USB signals to JTAG signals and is able to drive the MachXO2 device. Given this, the ispVM System software can download bitstreams directly into the MachXO2 SRAM, or bitstreams can be downloaded into the MachXO2 Flash memory.

LEDs

There are two LEDs on the MachXO2 Dual Sensor Interface Board that are used for general purpose signals, as described in Table 9.

Table 9. LEDs

| LED | MachXO2 Pin | Color | Function |
|------|-------------|-------|--|
| LED1 | J14 | Green | Indicate Line Valid and Frame Valid activity |
| LED2 | J12 | Red | |

Low Power SDRAM Memory

The MachXO2 Dual Sensor Interface Board is equipped with a 54-ball BGA low power SDRAM device, such as the IS42VM16400K in location U1. This provides memory resources with 16 bits of data width that span a 32M address space. The memory is powered by an on-board 1.8V regulator. The memory connects to the MachXO2 device on Banks 1, 3 and 4.

Table 10. MachXO2 Interface to Low Power SDRAM

| Signal Name | MachXO2 Pin (U8) | sysIO Bank | SDRAM Pin (U1) |
|-------------|------------------|------------|----------------|
| SDRAM_DQ0 | C14 | 1 | A8 |
| SDRAM_DQ1 | D12 | 1 | B9 |
| SDRAM_DQ2 | E12 | 1 | B8 |
| SDRAM_DQ3 | E14 | 1 | C9 |
| SDRAM_DQ4 | E13 | 1 | C8 |
| SDRAM_DQ5 | F12 | 1 | D9 |
| SDRAM_DQ6 | F13 | 1 | D8 |
| SDRAM_DQ7 | F14 | 1 | E9 |
| SDRAM_DQ8 | J13 | 1 | E1 |
| SDRAM_DQ9 | K12 | 1 | D2 |
| SDRAM_DQ10 | K13 | 1 | D1 |
| SDRAM_DQ11 | K14 | 1 | C2 |
| SDRAM_DQ12 | L14 | 1 | C1 |
| SDRAM_DQ13 | M13 | 1 | B2 |
| SDRAM_DQ14 | M12 | 1 | B1 |
| SDRAM_DQ15 | M14 | 1 | A2 |
| SDRAM_BA0 | B14 | 1 | G7 |
| SDRAM_BA1 | C13 | 1 | G8 |
| SDRAM_CAS_N | G12 | 1 | F7 |
| SDRAM_RAS_N | G14 | 1 | F8 |
| SDRAM_WE_N | N13 | 1 | F9 |
| SDRAM_CS_N | N14 | 1 | G12 |
| SDRAM_LDQM | G13 | 1 | E8 |
| SDRAM_UDQM | H12 | 1 | F1 |
| SDRAM_A0 | J3 | 3 | H7 |
| SDRAM_A1 | K2 | 3 | H8 |
| SDRAM_A2 | K1 | 3 | J8 |

Table 10. MachXO2 Interface to Low Power SDRAM (Continued)

| Signal Name | MachXO2 Pin (U8) | sysIO Bank | SDRAM Pin (U1) |
|-------------|------------------|------------|-----------------|
| SDRAM_A3 | K3 | 3 | J7 |
| SDRAM_A4 | L3 | 3 | J3 |
| SDRAM_A5 | M1 | 3 | J2 |
| SDRAM_A6 | M2 | 3 | H3 |
| SDRAM_A7 | F1 | 4 | H2 |
| SDRAM_A8 | F3 | 4 | H1 |
| SDRAM_A9 | H2 | 4 | G3 |
| SDRAM_A10 | H1 | 4 | H9 |
| SDRAM_A11 | H3 | 4 | G2 |
| SDRAM_CLK | J1 | 4 | F2 |
| SDRAM_CKE | J2 | 4 | F3 |
| SDRAM_NC_G1 | G3 | 4 | G1 ¹ |

1. SDRAM pin G1 is connected in case a larger memory size is desired in the future.

Configuring/Programming the DSIB

Requirements

- PC with Lattice Diamond design software version 1.3 (or later) installed with a USB driver.
Note: An option to install this driver is included as part of the Diamond setup.

For a complete discussion of the MachXO2 configuration and programming options, refer to TN1204, [MachXO2 Programming and Configuration Usage Guide](#).

Download Procedures

The download instructions below describe how to download JEDEC files into the MachXO2 Flash memory using the Diamond Programmer software. Bitstream downloads are done via a USB cable from a PC to the DSIB.

Note that the first download procedure shows the menus as viewed on a Windows XP operating system. The download procedures are very similar and do not show the menus.

The MachXO2 can be configured easily using the Diamond Programmer software to download a bitstream via a standard USB-A to USB-A cable.

1. Plug the MachXO2 Dual Sensor Interface Board into the HDR60 Base Board and power it up.
2. Connect the USB-A to USB-A cable from your PC's USB connector to the USB port on J13 of the DSIB.
3. Start the Diamond Programmer software. Create a new Project from a scan as shown in Figure 4. Alternatively, if Diamond Programmer is open, click the **Scan** button  .

Figure 4. Diamond Programmer Project Options



4. Under **Device**, select **LCMXO2-4000HE** from the pull-down menu (Figure 5).

Figure 5. Diamond Programmer New Scan Configuration Setup

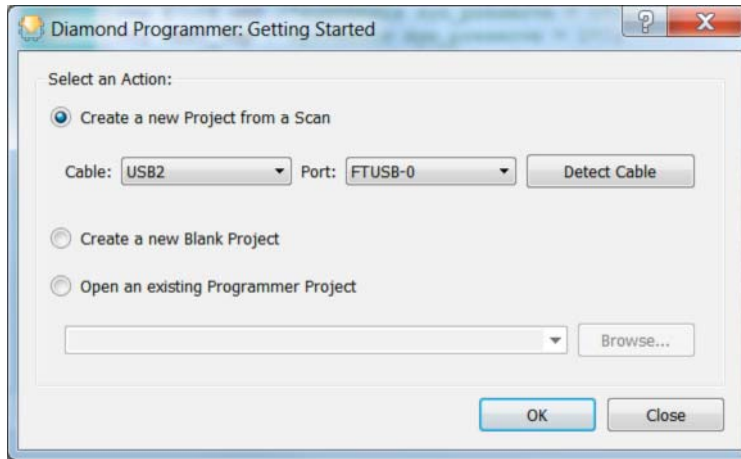
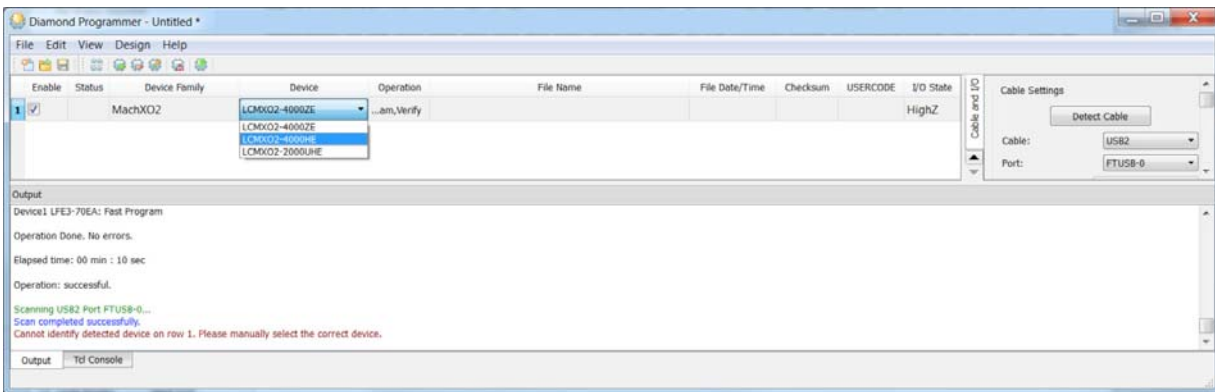

5. Next, double-click under the **filename** tab. Browse to the JEDEC programing file (*.jed) and click **OK**.

Figure 6. Select JEDEC File for Programming

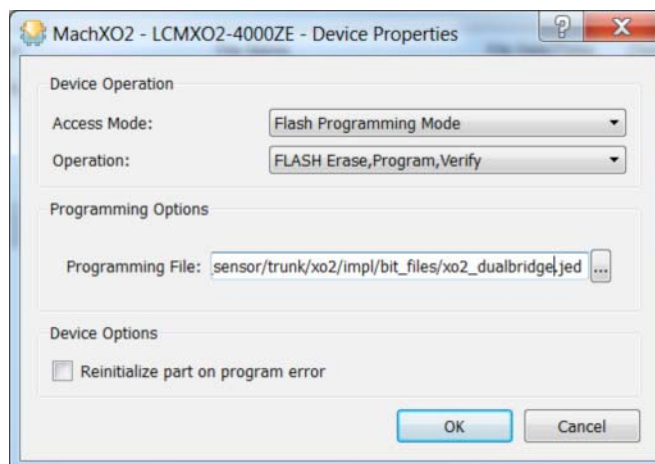

6. Click the **Program** button and wait for programming to complete.

Figure 7. Bitstream Download Operation Successful

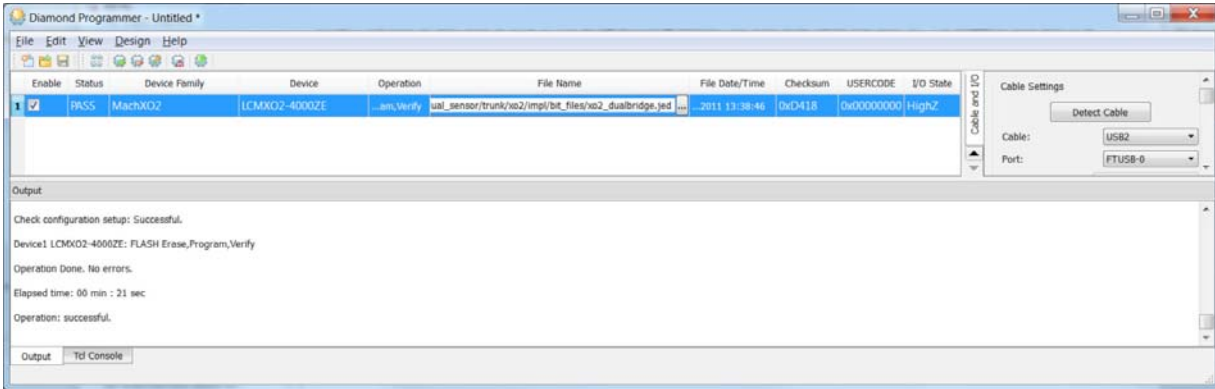

Ordering Information

| Description | Ordering Part Number | China RoHS Environment-Friendly Use Period (EFUP) |
|-------------------------------------|------------------------|---|
| MachXO2 Dual Sensor Interface Board | LCMXO2-4000HE-DSIB-EVN |  |

Technical Support Assistance

e-mail: techsupport@latticesemi.com

Internet: www.latticesemi.com

Revision History

| Date | Version | Change Summary |
|---------------|---------|---|
| January 2012 | 01.0 | Initial release. |
| November 2013 | 01.1 | Added link to Dual HiSPi Sensor Interface Bridge page in the General Description section. |
| | | Updated corporate logo. |
| | | Updated Technical Support information. |

© 2013 Lattice Semiconductor Corp. All Lattice trademarks, registered trademarks, patents, and disclaimers are as listed at www.latticesemi.com/legal. All other brand or product names are trademarks or registered trademarks of their respective holders. The specifications and information herein are subject to change without notice.

Appendix A. Schematics

Figure 8. Block Diagram

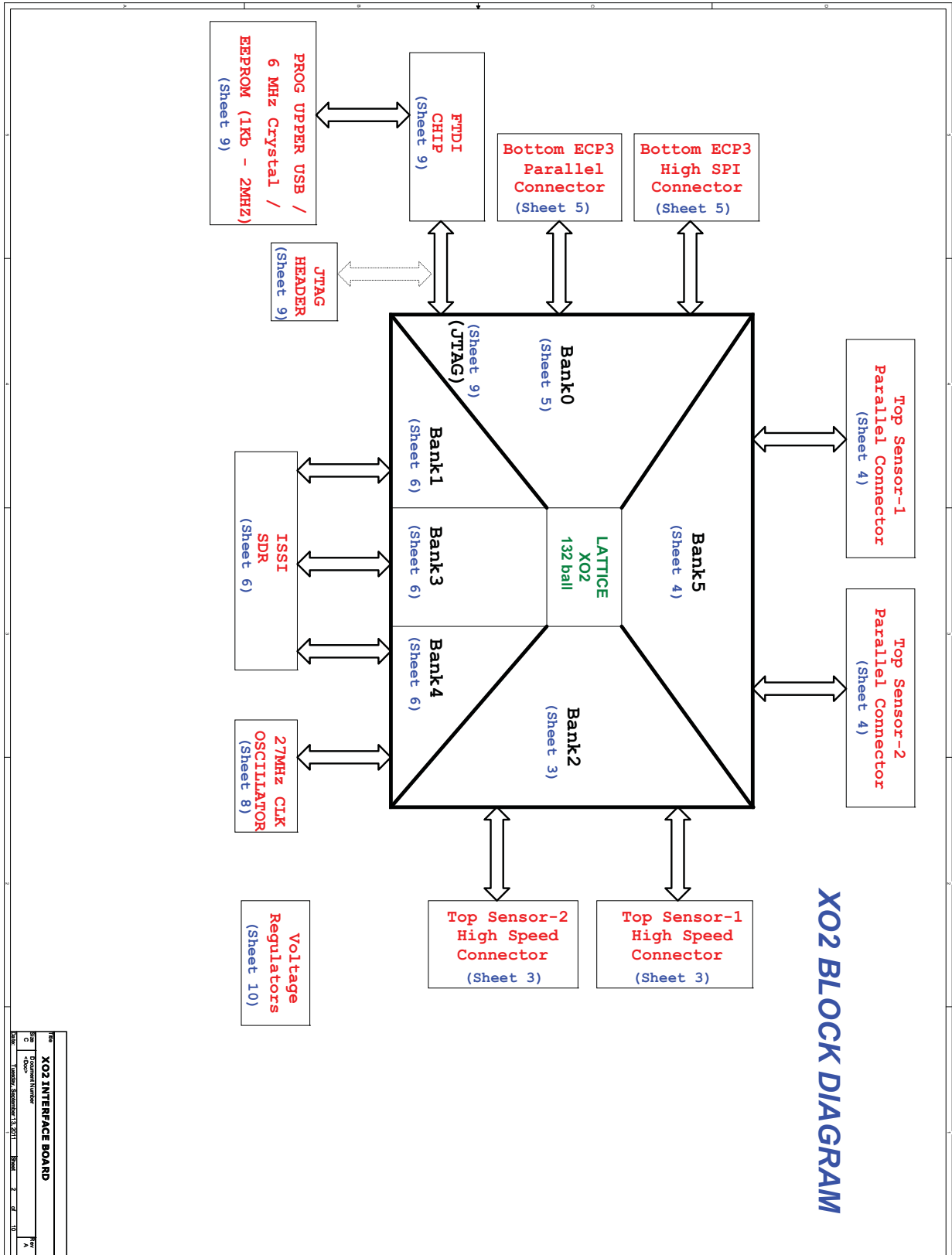

Figure 12. SDR-FPGA Connections

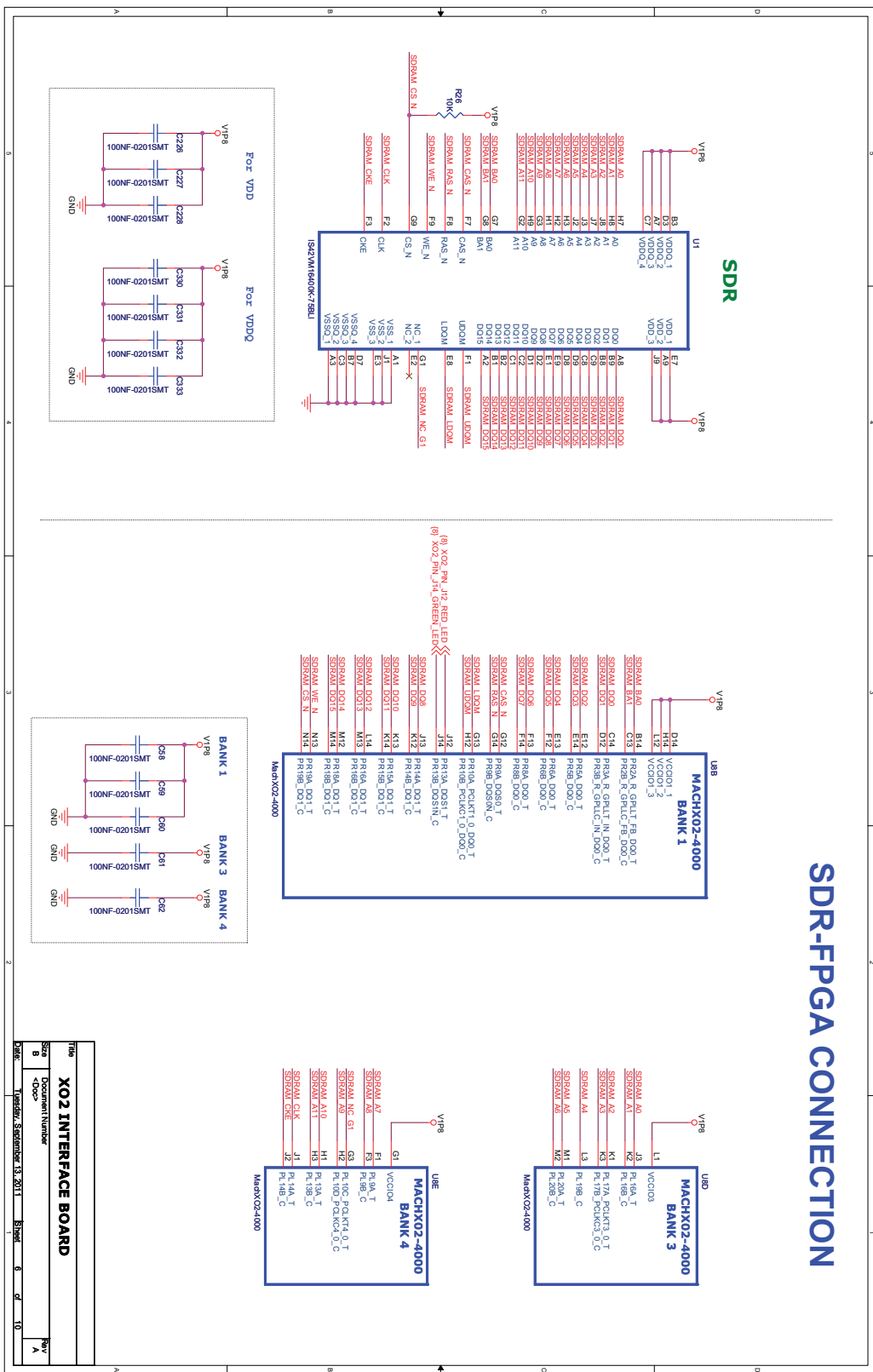

Figure 14. MachXO2 Power, Ground and Miscellaneous

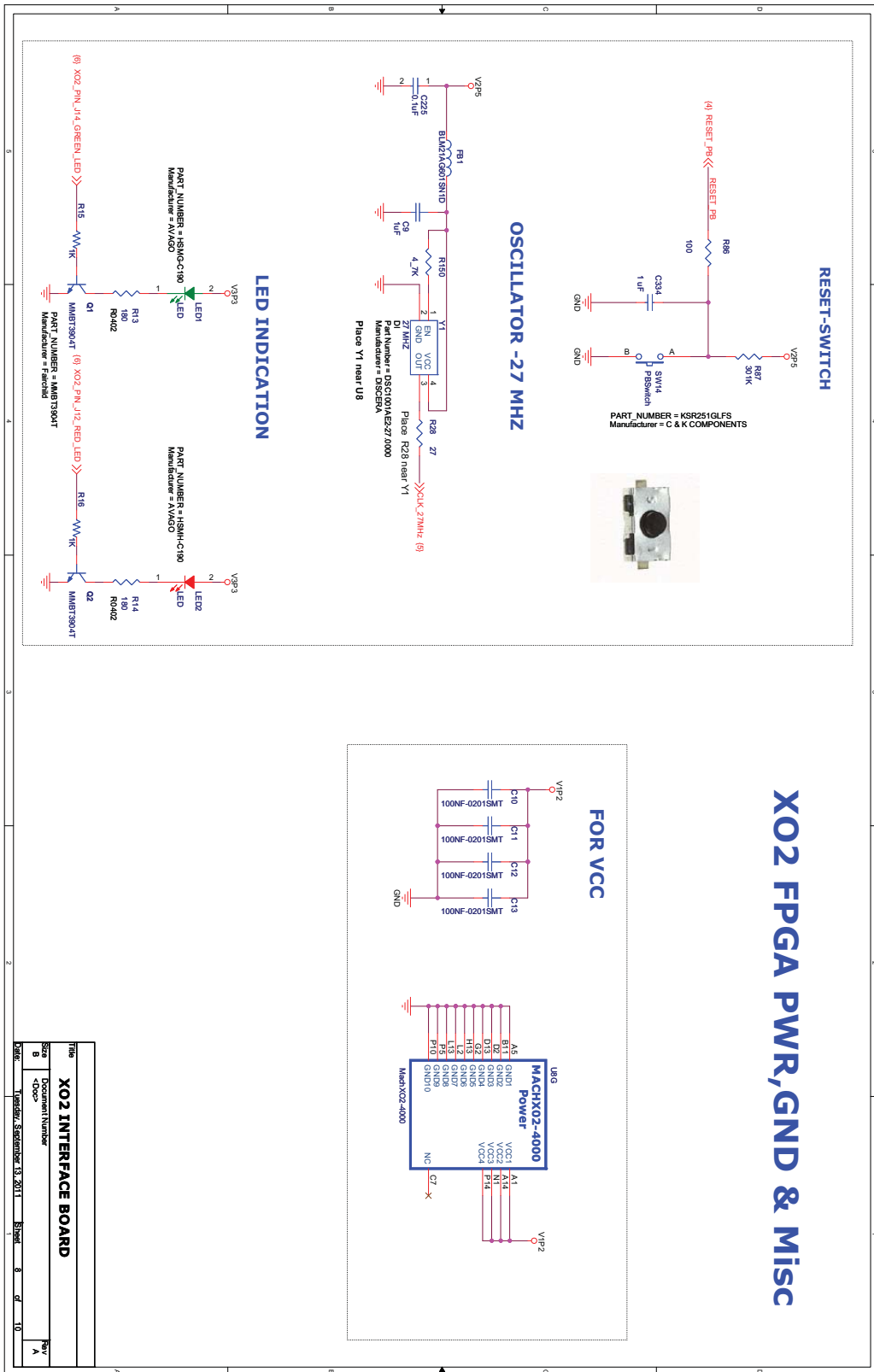
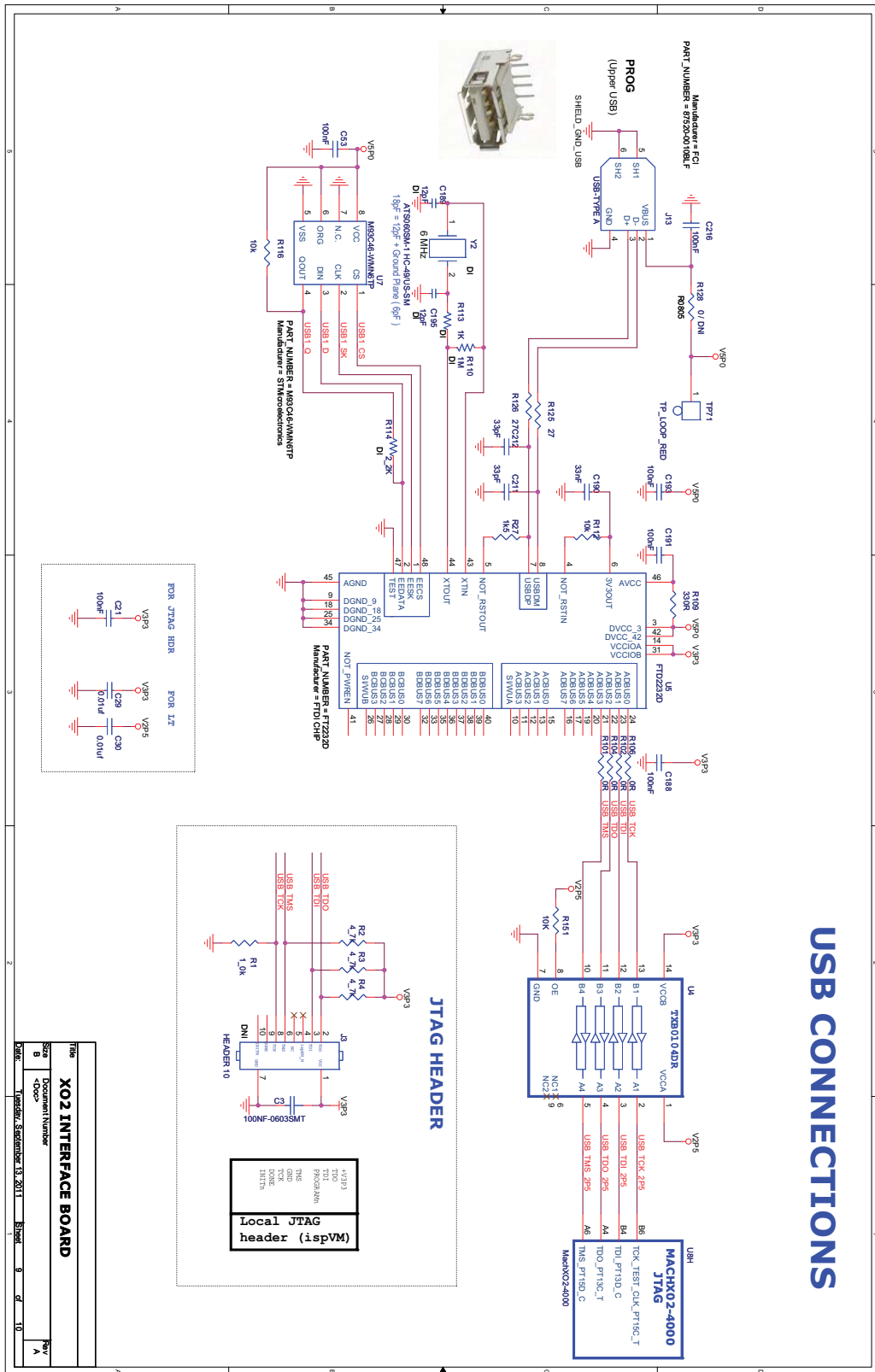

Figure 15. USB Download



Appendix B. Programming Using JTAG Flywire Connections

The MachXO2 Dual Sensor Interface Board includes provision for the flywire-connected programming header J3. The pins for the J3 header are not installed, as typical use of the board is through the USB download. To use a flywire JTAG connection rather than the built-in USB download at J13, the user will need to first acquire the flywire download cable and connect it to J3. The pinout for J3 is provided in Table 11.

Important Note: The board must be un-powered when connecting, disconnecting or reconnecting an ispDOWNLOAD cable or USB cable. Always connect an ispDOWNLOAD cable's GND pin (black wire), before connecting any other JTAG pins. Failure to follow these procedures can in result in damage to the LatticeECP3 FPGA and render the board inoperable.

Table 11. JTAG Flywire Programming Header

| | J3 Function |
|----|--------------------|
| 1 | 3_3V |
| 2 | TDO |
| 3 | TDI |
| 4 | NC |
| 5 | NC |
| 6 | TMS |
| 7 | GND |
| 8 | TCK |
| 9 | NC |
| 10 | NC |

Requirements:

- PC with Lattice Diamond design software version 1.3 (or later), installed with appropriate drivers (USB driver for USB Cable, Windows NT/2000/XP parallel port driver for ispDOWNLOAD Cable). *Note: An option to install these drivers is included as part of the ispVM System setup.*
- Any ispDOWNLOAD or Lattice USB Cable (pDS4102-DL2x, HW7265-DL3x, HW-USB-2x, etc.).

Appendix C. Bill of Materials

Table 12. MachXO2 Dual Sensor Interface Board Bill of Materials

| Item | Qty | Reference | Part | PCB Footprint | Part Number | Manufacturer | Description |
|------|-----|---|-----------------------------|-----------------------------|---------------------|-----------------|--------------------------------------|
| 1 | 23 | C1, C2, C6, C10, C11, C12, C13, C58, C59, C60, C61, C62, C220, C221, C222, C224, C226, C227, C228, C330, C331, C332, C333 | 100NF-0201SMT | C0201 | LMK063BJ104KP-F | Taiyo Yuden | CAP CER .10UF 10V X5R 0201 |
| 2 | 2 | C189, C195 | 12pF | C0603 | C1608C0G1H120J | TDK | CAP CER 12PF 50V C0G 5% 0603 |
| 3 | 1 | C190 | 33nF | C0402 | ECJ-0EB1A333K | Panasonic - ECG | CAP 33000PF 10V CERAMIC X5R 0402 |
| 4 | 1 | C21 | 100nF | C0201 | LMK063BJ104KP-F | Taiyo Yuden | CAP CER .10UF 10V X5R 0201 |
| 5 | 2 | C211, C212 | 33pF | C0402 | ECJ-0EC1H330J | Panasonic - ECG | CAP 33PF 50V CERAMIC 0402 SMD |
| 6 | 1 | C225 | 0.1uF | C0402 | GRM155F51E104ZA01D | Murata | CAP - CER, 0.1uF, 0402, 25VDC, Y5V |
| 7 | 2 | C29, C30 | 0.01uf | C0402 | C1005X8R1E103K | TDK | CAP CER 0.01UF 25V X8R 10% 0402 |
| 8 | 1 | C3 | 100NF-0603SMT | C0603 | 0603YC104JAZ2A | AVX | CAP CER .10UF 16V X7R 5% 0603 |
| 9 | 1 | C334 | 1 uF | C0603 | C1608X7R1C105K | TDK | CAP CER 1.0UF 16V X7R 10% 0603 |
| 10 | 9 | C4, C7, C8, C76, C77, C79, C82, C84, C85 | 22uF, 6.3V | C0805 | C2012X5R1C226K | TDK | CAP CER 22UF 16V X5R 10% 0805 |
| 11 | 2 | C5, C80 | 10uF, 25V | C1206 | TMK316B7106KL-TD | Taiyo Yuden | CAP CER 10UF 25V X7R 10% 1206 |
| 12 | 5 | C53, C188, C191, C193, C216 | 100nF | C0402 | ECJ-0EB1A104K | Panasonic - ECG | CAP 0.1UF 10V CERAMIC X5R 0402 |
| 13 | 4 | C63, C66, C68, C71 | 10pF | C0402 | 04025U100FAT2A | AVX | CAP CERM 10PF 50V NPO RF 0402 |
| 14 | 4 | C64, C65, C70, C72 | 150pF | C0402 | C1005C0G1H151J | TDK | CAP CER 150PF 50V C0G 5% 0402 |
| 15 | 4 | C67, C69, C75, C78 | 1000pF | C0402 | GRM155R71H102KA01D | Murata | CAP 1000PF 50V CERAMIC X7R 0402 SMD |
| 16 | 4 | C73, C74, C81, C83 | 0.22uF | C0402 | GRM155R71C224KA12D | Murata | CAP CER .22UF 16V X7R 0402 |
| 17 | 1 | C9 | 1uF | C0402 | ECJ-0EB0J105K | Panasonic | CAP CERAMIC 1UF 6.3V X5R 0402 |
| 18 | 4 | D1, D2, D3, D4 | DFLS220L | POWERDI123-KS | DFLS220L-7 | Diodes Inc | DIODE SCHOTTKY 2A 20V PWRDI 123 |
| 19 | 4 | D5, D6, D7, D8 | 1N4448W | SOD123 | 1N4448W-7-F | Diodes Inc | DIODE SWITCH 75V 400MW SOD123 |
| 20 | 1 | FB1 | BLM21AG601SN1D | FB0805 | BLM21AG601SN1D | Murata | FERRITE CHIP 600 OHM 200MA 0805 |
| 21 | 2 | J1, J4 | DF12_40DS-0.5V_ RECEPTACLE | HRS-DF12A-RECEPTACLE-CENTER | DF12(4.0)-40DS-0.5V | Hirose | CONN RECEPT 40POS 0.5MM GOLD SMD |
| 22 | 1 | J13 | USB-TYPE A | 87520-0010BLF | 87520-0010BLF | FCI | CONN RCPT USB TYPE A R/A PCB |
| 23 | 3 | J14, J15, J16 | 2 PIN JPR | 2PIN_JPR_100MIL | — | — | — |
| 24 | 2 | J2, J10 | 4PIN_SMD_0603 | 4PIN_JPR_0603 | — | — | — |
| 25 | 1 | J21 | 3PIN_SMD_0603 | 3PIN_SMD_0603 | — | — | — |
| 26 | 1 | J3 | HEADER 10 | HD10x1 | — | — | — |
| 27 | 2 | J5, J11 | DF12(4.0)-40DP-0.5V_ HEADER | HRS-DF12A-HEADER | DF12(4.0)-40DP-0.5V | Hirose | CONN HEADER 40POS 4MM SMD 0.5MM |
| 28 | 2 | J6, J20 | HDR3_100MIL | HDR3_100MIL | — | — | — |
| 29 | 1 | J7 | DF12_40DS-0.5V_ RECEPTACLE | HIROSE-DF12_40DS-0_5V | DF12(4.0)-40DS-0.5V | Hirose | CONN RECEPT 40POS 0.5MM GOLD SMD |
| 30 | 1 | J8 | DF12(4.0)-40DP-0.5V_ HEADER | HIROSE-DF12_40DP-0_5V | DF12(4.0)-40DP-0.5V | Hirose | CONN HEADER 40POS 4MM SMD 0.5MM |
| 31 | 1 | J9 | BL112-36S | BL112-36S | BL112-36S | SWITCHTECH | 36PIN TI INTERFACE CONNECTOR |
| 32 | 1 | L1 | 6.8uH | L-CDRH3D18 | CDRH3D18NP-6R8N | Sumida | 4 x 4 x 2 mm, 6.8uH Power inductor |
| 33 | 1 | L2 | 6.8uH | L-CDRH4D18C | CDRH4D18CNP-6R8P | Sumida | 5.1x5.1x2.0 mm, 6.8uH Power inductor |
| 34 | 1 | L3 | 4.7uH | L-CDRH3D18 | CDRH3D18NP-4R7N | Sumida | 4 x 4 x 2 mm, 4.7uH Power inductor |
| 35 | 1 | L4 | 4.7uH | L-CDRH4D18C | CDRH4D18CNP-4R7P | Sumida | 5.1x5.1x2.0 mm, 4.7uH Power inductor |
| 36 | 1 | LED1 | LED | LED0603 | HSMG-C190 | Avago | LED 570NM GREEN DIFF 0603 SMD |

Table 12. MachXO2 Dual Sensor Interface Board Bill of Materials (Continued)

| Item | Qty | Reference | Part | PCB Footprint | Part Number | Manufacturer | Description |
|------|-----|---|-------------------|----------------------|-------------------|------------------|--|
| 37 | 1 | LED2 | LED | LED0603 | HSMH-C190 | Avago | LED 660NM RED DIFF 0603 SMD |
| 38 | 4 | PP1, PP2, PP3, PP4 | PROBEPOINT | probepoint | — | — | — |
| 39 | 2 | Q1, Q2 | MMBT3904T | SOT-523F_MMBT | MMBT3904T | Fairchild | TRANS NPN 40V 200MA SOT-523F |
| 40 | 1 | R1 | 1_0k | R0603 | ERJ-3EKF1001V | Panasonic - ECG | RES 1.00K OHM 1/10W 1% 0603 SMD |
| 41 | 4 | R101, R102, R104, R106 | 0R | R0603 | ERJ-3GEY0R00V | Panasonic - ECG | RES 0.0 OHM 1/10W 0603 SMD |
| 42 | 1 | R109 | 330R | R0603 | ERJ-3GEYJ331V | Panasonic - ECG | RES 330 OHM 1/10W 5% 0603 SMD |
| 43 | 1 | R110 | 1M | R0603 | RC0603FR-071ML | Yageo | RES 1.00M OHM 1/10W 1% 0603 SMD |
| 44 | 2 | R112, R116 | 10k | R0603 | RNCS0603BKE10K0 | Stackpole | RES 1/16W 10K OHM 0.1% 0603 |
| 45 | 1 | R113 | 1K | R0603 | ERJ-3EKF1001V | Panasonic - ECG | RES 1.00K OHM 1/10W 1% 0603 SMD |
| 46 | 1 | R114 | 2_2K | R0603 | ERJ-3EKF2201V | Panasonic - ECG | RES 2.20K OHM 1/10W 1% 0603 SMD |
| 47 | 1 | R128 | 0 / DNI | R0805 | — | — | — |
| 48 | 2 | R13, R14 | 180 | R0402 | CRCW0402180RFKED | Vishay | RES 180 OHM 1/16W 1% 0402 SMD |
| 49 | 2 | R15, R16 | 1K | R0402 | CRCW04021K00FKED | Vishay | RES 1.00K OHM 1/16W 1% 0402 SMD |
| 50 | 1 | R150 | 4_7K | R0402 | MCR01MZPJ472 | Rohm | RES 4.7K OHM 1/16W 5% 0402 SMD |
| 51 | 3 | R2, R3, R4 | 4_7k | R0603 | ERJ-3EKF4701V | Panasonic - ECG | RES 4.70K OHM 1/10W 1% 0603 SMD |
| 52 | 2 | R26, R151 | 10K | R0402 | ERJ-2RKF1002X | Panasonic | RES 10.0K OHM 1/10W 1% 0402 SMD |
| 53 | 1 | R27 | 1k5 | R0603 | ERJ-3EKF1501V | Panasonic - ECG | RES 1.50K OHM 1/10W 1% 0603 SMD |
| 54 | 3 | R28, R125, R126 | 27 | R0603 | ERJ-3GEYJ270V | Panasonic - ECG | RES 27 OHM 1/10W 5% 0603 SMD |
| 55 | 2 | R29, R30 | DNL | R0603 | — | — | — |
| 56 | 6 | R41, R42, R44, R47, R49, R50 | 51k | R0402 | ERJ-2RKF5102X | Panasonic | RES 51.0K OHM 1/10W 1% 0402 SMD |
| 57 | 1 | R43 | 34k | R0402 | ERJ-2RKF3402X | Panasonic | RES 34.0K OHM 1/10W 1% 0402 SMD |
| 58 | 1 | R45 | 11.5k | R0402 | ERJ-2RKF1152X | Panasonic | RES 11.5K OHM 1/10W 1% 0402 SMD |
| 59 | 1 | R46 | 35.7k | R0402 | ERJ-2RKF3572X | Panasonic | RES 35.7K OHM 1/10W 1% 0402 SMD |
| 60 | 1 | R48 | 63.4k | R0402 | ERJ-2RKF6342X | Panasonic - ECG | RES 63.4K OHM 1/10W 1% 0402 SMD |
| 61 | 4 | R5, R11, R12, R52 | 10_0K | R0402 | ERJ-2RKF1002X | Panasonic | RES 10.0K OHM 1/10W 1% 0402 SMD |
| 62 | 2 | R51, R58 | 22_1K-0603SMT | R0603 | ERJ-3EKF2212V | Panasonic - ECG | RES 22.1K OHM 1/10W 1% 0603 SMD |
| 63 | 2 | R53, R59 | 21_5K | R0402 | ERJ-2RKF2152X | Panasonic | RES 21.5K OHM 1/10W 1% 0402 SMD |
| 64 | 1 | R54 | 5_11K | R0402 | ERJ-2RKF5111X | Panasonic | RES 5.11K OHM 1/10W 1% 0402 SMD |
| 65 | 2 | R56, R57 | 8_06K-0603SMT | R0603 | CRCW06038K06FKEA | Vishay | RES 8.06K OHM 1/10W 1% 0603 SMD |
| 66 | 1 | R6 | 10k | R0402 | ERJ-2RKF1002X | Panasonic | RES 10.0K OHM 1/10W 1% 0402 SMD |
| 67 | 17 | R71, R72, R73, R74, R75, R76, R77, R78, R79, R80, R81, R82, R83, R84, R85, R88, R89 | 33 | R0402 | ERA-2AKD330X | Panasonic | RES 33 OHM 1/16W .5% 0402 SMD |
| 68 | 1 | R86 | 100 | R0402 | ERA-2AEB101X | Panasonic | RES 100 OHM 1/16W .1% 0402 SMD |
| 69 | 1 | R87 | 301K | R0402 | ERJ-2RKF3013X | Panasonic | RES 301K OHM 1/10W 1% 0402 SMD |
| 70 | 1 | SW14 | PBSwitch | PUSHBUTTON_KSR251 | KSR251GLFS | C & K COMPONENTS | SWITCH TACT SILVR 450GF GULLWING |
| 71 | 6 | TP66, TP67, TP68, TP69, TP70, TP71 | TP_LOOP_RED | TP_RED_5000 | 5000 | Keystone | TEST POINT PC MINI .040"D RED |
| 72 | 2 | TP90, TP91 | TP_LOOP_BLACK | TP_BLACK_5001 | 5001 | Keystone | TEST POINT PC MINI .040"D BLACK |
| 73 | 1 | U1 | IS42VM16400K-6BLI | 54_FBGA_IS42VM16400G | IS42VM16400K-6BLI | ISSI | 1M x 16Bits x 4Banks Mobile Synchronous DRAM |

Table 12. MachXO2 Dual Sensor Interface Board Bill of Materials (Continued)

| Item | Qty | Reference | Part | PCB Footprint | Part Number | Manufacturer | Description |
|------|-----|----------------------------|---------------------------|----------------------------|-----------------------|------------------------|---|
| 74 | 2 | U10, U11 | LT3508EUF | QFN24UF-4X4 | LT3508EUF#PBF | Linear Technology | IC REG 1.4A DUAL MONO 24-QFN |
| 75 | 1 | U4 | LT_TXB0104DR | SOIC14 TXB0104DR | TXB0104DR | Texas Instruments | SOIC, 14pins, 4bit, Bidirectional, Voltage Level translator |
| 76 | 1 | U5 | FTD2232D | LQFP48 | FT2232D | FTDI Chip | Dual USB to serial UART/FIFO IC |
| 77 | 1 | U7 | M93C46- WMN6TP | SO-08NARROW_150MIL | M93C46-WMN6TP | STMicroelectronics | IC EEPROM 1KBIT 2MHZ 8SOIC |
| 78 | 1 | U8 | MachXO2-4000 | 132_CSBGA_ MACHXO2_4000 | LCMXO2-4000HE-6MG132C | Lattice Semiconductor | MachXO2-4000 in the 132csBGA package |
| 79 | 1 | Y1 | 27 MHZ | DSC1001- CE-27_000 | DSC1001AE2-27.0000 | DISCERA | OSC 27.0000 MHZ 1.7-3.6V SMD |
| 80 | 1 | Y2 | ATS060SM-1 HC-49/US-SM | ATS060SM | ATS060SM-1 | CTS-Frequency Controls | CRYSTAL 6.0000MHZ SMD |
| 81 | 1 | X02_INTERFACE_BOARD PCB | — | — | 305-PD-11-0678 | Pactron | — |

Mouser Electronics

Authorized Distributor

Click to View Pricing, Inventory, Delivery & Lifecycle Information:

Lattice:

[LCMXO2-4000HE-DSIB-EVN](#)