

# APPLICATION TOOLING

Crimping tools and machines

**Crimping tools and machines**

The arrow mark indicates the press that is applicable to the applicator.

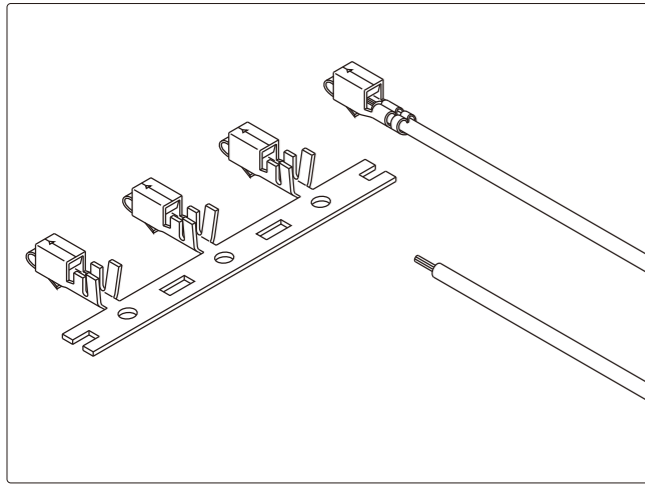

**Strip-crimp applicator  
for side feeding terminals**

MKS-L

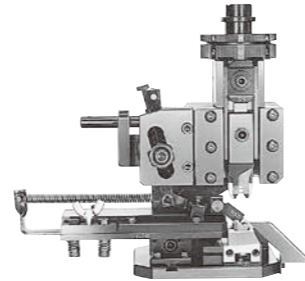

**Crimping applicator  
for end-feeding terminals**

MK-L

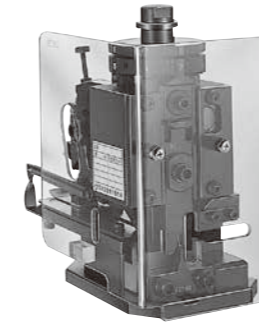

## Semi-automatic press

Semi-automatic crimping machines (presses) contact a wire to a chain terminal each time a footswitch is pressed.

AP-K2N

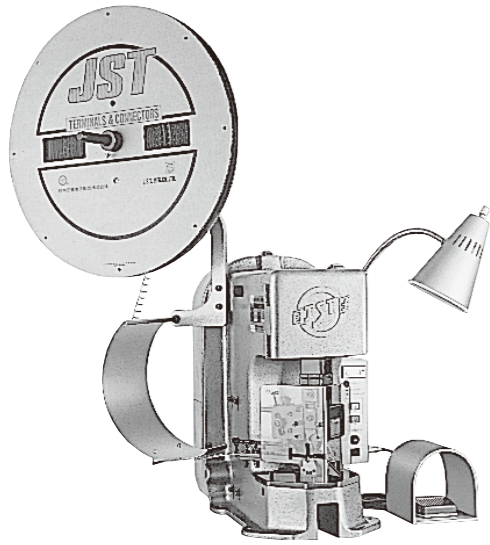







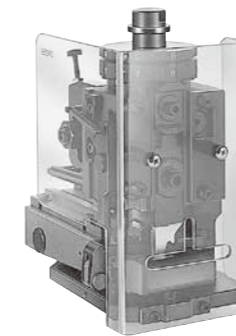

- Dimensions:  
(W×L×H)280×480×505 mm
- Weight:  
Approx. 90 kg(198 lb)
- Power source:  
100 VAC, Single-phase 50/60 Hz
- Pressure output:  
14.7 kN[1,500 kg(3307 lb)]
- Dies:  
Applicator replacement

**Crimping applicator  
for end-feeding flag terminals**

MKF-L



### Crimping tools

| Terminals and parts model number in alphabetical order | Hand tools  |   |   |  |   | Hand tools  |                                     |                                     | Extraction and Insertion tools  |   |
|--|---|---|---|--|---|---|-------------------------------------|-------------------------------------|---|---|
|  | for chain terminals   | for loose piece terminals   |   |  |   | for loose piece terminals   |                                     |                                     | Extraction tool   | Insertion tool  |
|  | YRS series  | YC series   | YRM series  | YRF series   | YRK series  | YRK-EX series   |                                     |                                     |   |   |
|  |    |  |  |  |  |  |                                     |                                     |  |  |
|  | Dimensions: (W×L) 59×224 mm   | Dimensions: (W×L) 70×296 mm   | Dimensions: (W×L) 59×224 mm   | Dimensions: (W×L) 70×295 mm<br>80×305 mm   | Dimensions: (W×L×D) 75×314×25 mm  | Dimensions: (W×L×D) 75×314×25 mm  |                                     |                                     |   |   |
|  | <p><b>Crimping tools</b><br/>It is the manual tool that is convenient to terminate very small quantity of contacts for prototype or maintenance. It is composed of two crimping dies for the conductor and insulation, and can be crimp easily. YRK and YRK-EX can be used for mass-production.</p> <p>Note: (1) These tools are for prototype tooling or repair.<br/>(2) YC tool has two crimping sections (A and B). YRS tool has also two crimping sections by inverting upper dies. Be sure to check applicable wires before use. Since the dies are fixed, the crimping height cannot be adjusted. Therefore, some of the applicable wires described in this catalog may not be crimped properly. Before use, check for proper crimping (such as tensile strength, terminal/contact deformation).<br/>(3) These tools are not applicable to 2-wire crimping.<br/>(4) When hand crimping board-in terminals (SAN, SCN, SDN, SGN, SIN, SJN, SZN), care should be taken not to contaminate the solder tails of the terminals, as with greasy or oily fingers. If a solder problem arises, some cleaning of the tips of the terminal is advisable.<br/>(5) WC and JUC hand tools are provided by J.S.T.(U.K.) LTD. and contact them about the details of these hand tools.</p> |   |   |  |   |   |                                     |                                     |   |   |
|  | YRS series  | YC series   | YRM series  | YRF series   | YRK · YRK-EX series   |   | WC & JUC series<br>JUK's Hand Tools | Terminal in loose form<br>model No. |   |   |
| JK-SP2***/JK-SS2***                                    | YRS-370   | —   | —   | —  | —   |   | —                                   | —                                   | KEJ-0.7 for plug, KEJ-0.4 for socket  | —   |
| J-SP1***/J-SS1***                                      | YRS-440   | YC-440  | —   | —  | —   |   | —                                   | J-BP/BS1***                         | DEJ-0.3   | —   |
| J-SP2***/J-SS2***                                      | YRS-330   | —   | —   | —  | —   |   | —                                   | —                                   | DEJ-0.3   | —   |
| LFO-1.0-250N   | —   | —   | —   | —  | —   |   | JUCS-FO                             | —                                   | —   | —   |
| LFO-2.5-250N   | —   | —   | —   | —  | —   |   | JUCS-FO                             | —                                   | —   | —   |
| MD-SP12**  | YRS-470   | —   | —   | —  | —   |   | —                                   | —                                   | MEJ-06  | —   |
| MD-SP22**  | YRS-460   | —   | —   | —  | —   |   | —                                   | —                                   | MEJ-06  | —   |
| RA-SC1290  | YRS-231   | —   | YRM-232<br>YRM-233  | —  | —   |   | —                                   | RA-BC12**                           | EJ-RA   | —   |
| RF-SC22**  | —   | —   | YRM-230   | —  | —   |   | —                                   | RF-BC22**                           | —   | —   |
| RPJ-SP2331<br>RPJ-SS2331                               | YRS-331   | —   | —   | —  | —   |   | —                                   | —                                   | EJ-RPJ  | —   |
| SAA-21(T)**  | —   | YC-141  | —   | —  | —   |   | —                                   | LAA-21(T)**                         | —   | —   |
| SAA-50(T)**  | —   | YC-182  | —   | —  | —   |   | —                                   | LAA-50(T)**                         | —   | —   |
| SAA-51(T)**  | —   | YC-142  | —   | —  | —   |   | —                                   | LAA-51(T)**                         | —   | —   |
| SAB-51(T)**  | —   | YC-142  | —   | —  | —   |   | —                                   | LAB-51(T)**                         | —   | —   |
| SACH-003G-P0.2   | YRS-1190  | —   | —   | —  | —   |   | —                                   | —                                   | —   | —   |
| SAGH-002GU-P0.3  | YRS-858   | —   | —   | —  | —   |   | —                                   | —                                   | —   | —   |
| SAN-002T-0.8A<br>SAN-002T-0.8K                         | YRS-220   | —   | —   | —  | —   |   | —                                   | —                                   | EJ-PH   | —   |
| SBH-001T-P0.5  | —   | YC-670R   | —   | —  | —   |   | WC-670                              | BBH-001T-P0.5                       | —   | —   |
| SBHL-002T-P0.5   | YRS-857   | —   | —   | —  | —   |   | —                                   | —                                   | —   | —   |
| SBHM-001T-P0.5   | —   | YC-670R   | —   | —  | —   |   | —                                   | BBHM-001T-P0.5                      | EJ-BHMR   | —   |
| SBHS-002T-P0.5A  | YRS-852   | —   | —   | —  | —   |   | —                                   | —                                   | EJ-BHS2   | —   |
| SBHS-002T-P0.5A  | —   | —   | —   | —  | —   |   | —                                   | —                                   | EJ-BHS2   | —   |
| SBHSM-002T-P0.5  | YRS-854   | —   | —   | —  | —   |   | —                                   | —                                   | EJ-BHSW   | —   |
| SBHT-002T-P0.5   | YRS-856<br>YRS-857  | —   | —   | —  | —   |   | —                                   | —                                   | EJ-BHT  | —   |
| SBN-001T-1.0   | YRS-170   | YC-170R   | —   | —  | —   |   | —                                   | BBN-001T-1.0                        | —   | —   |
| SCN-001T-1.0K<br>SCN-001T-P1.0                         | YRS-191   | YC-191R   | —   | —  | —   |   | WC-191                              | BCN-001T-1.0K<br>BCN-001T-P1.0      | —   | —   |
| SCS-41T-2.3  | —   | —   | —   | —  | —   |   | —                                   | —                                   | CSJ-23  | —   |
| SCSH-002T-P0.2N  | YRS-1350  | —   | —   | —  | —   |   | —                                   | —                                   | —   | —   |

Note: Contact JST for wire range.

Crimping tools

| Terminals and parts model number in alphabetical order | Hand tools           |                           |            |            |                     | Hand tools                          |                                     |                                       | Extraction and Insertion tools |                |
|--|----------------------|---------------------------|------------|------------|---------------------|-------------------------------------|-------------------------------------|---------------------------------------|--------------------------------|----------------|
|  | for chain terminals  | for loose piece terminals |            |            |                     | for loose piece terminals           |                                     |                                       | Extraction tool                | Insertion tool |
|  | YRS series           | YC series                 | YRM series | YRF series | YRK · YRK-EX series | WC & JUC series<br>JUK's Hand Tools | Terminal in loose form<br>model No. |                                       |                                |                |
| SCSN-41T-P2.3  | --                   | --                        | --         | --         | --                  | --                                  | --                                  | --                                    | EJ-CSN                         | --             |
| SCZH-002T-P0.5   | YRS-492              | --                        | --         | --         | --                  | --                                  | --                                  | --                                    | --                             | --             |
| SDACP-002T-M0.9  | YRS-1530<br>YRS-1531 | --                        | --         | --         | --                  | --                                  | --                                  | --                                    | --                             | --             |
| SDF-01T-1.0A<br>SDF-01T-1.3AS                          | --                   | YC-045                    | --         | --         | --                  | --                                  | --                                  | LDF-01T-1.0A<br>LDF-01T-1.3AS         | --                             | --             |
| SDN-21T-P1.5   | --                   | YC-600R                   | --         | --         | --                  | --                                  | --                                  | BDN-21T-P1.5                          | --                             | --             |
| SDY-01T-P1.6ASV  | --                   | YC-525R                   | --         | --         | --                  | --                                  | --                                  | BDY-01T-P1.6ASV                       | SLJ-1.4                        | --             |
| SEH-001T-P0.6  | YRS-260              | YC-260R                   | --         | --         | --                  | --                                  | WC-260                              | BEH-001T-P0.6                         | EJ-PH                          | --             |
| SEH-001T-P0.6L   | --                   | --                        | --         | --         | --                  | --                                  | --                                  | --                                    | EJ-PH                          | --             |
| SEH-002T-P0.6L   | --                   | --                        | --         | --         | --                  | --                                  | --                                  | --                                    | EJ-PH                          | --             |
| SEH-003T-P0.6L   | --                   | --                        | --         | --         | --                  | --                                  | --                                  | --                                    | EJ-PH                          | --             |
| SF1F-01GC-P0.6<br>SF1M-01GC-M0.6A                      | --                   | --                        | --         | --         | YRK-1230            | --                                  | --                                  | --                                    | --                             | --             |
| SF1F-002T(GC)-P0.6<br>SF1M-002T(GC)-M0.6A              | --                   | --                        | --         | --         | YRK-1220            | --                                  | --                                  | --                                    | EJ-JFAJ1100                    | --             |
| SF1F-21T(GC)-P0.6<br>SF1M-21T(GC)-M0.6A                | --                   | --                        | --         | --         | YRK-1210            | --                                  | --                                  | --                                    | EJ-JFAJ1100                    | --             |
| SF3F-002(*)-P2.0<br>SF3M-002(*)-M2.0N                  | --                   | --                        | --         | YRF-882    | YRK-8821            | --                                  | --                                  | BF3F-002(*)-P2.0<br>BF3M-002(*)-M2.0N | EJ-JFAJ3                       | --             |
| SF3F-01(*)-P2.0<br>BF3M-002(*)-M2.0N                   | --                   | --                        | --         | YRF-881    | YRK-8811            | --                                  | --                                  | BF3F-01(*)-P2.0<br>BF3M-01(*)-M2.0N   | EJ-JFAJ3                       | --             |
| SF3F-41(*)-P2.0<br>SF3M-41(*)-M2.0N                    | --                   | --                        | --         | YRF-880    | YRK-8801            | --                                  | --                                  | LF3F-41(*)-P2.0<br>LF3M-41(*)-M2.0N   | EJ-JFAJ3                       | --             |
| SF3F-71(*)-P2.0<br>SF3M-71(*)-M2.0N                    | --                   | --                        | --         | YRF-1070   | YRK-1071            | --                                  | --                                  | BF3F-71(*)-P2.0<br>BF3M-71(*)-M2.0N   | EJ-JFAJ3                       | --             |
| SFO-41(T)-187N(-8)                                     | --                   | YC-271                    | --         | --         | --                  | --                                  | --                                  | LFO-41(T)-187N                        | --                             | --             |
| SFO-61(T)-250A   | --                   | YC-270                    | --         | --         | --                  | --                                  | --                                  | LFO-61(T)-250A                        | --                             | --             |
| SFPS-61T-250   | --                   | YC-272                    | --         | --         | --                  | --                                  | --                                  | LFPS-61(T)-250                        | --                             | --             |
| SFT-61T-250N   | --                   | YC-510                    | --         | --         | --                  | --                                  | --                                  | LFT-61T-250N                          | --                             | --             |
| SGF-41(T)-4  | --                   | YC-055                    | --         | --         | --                  | --                                  | --                                  | LGF-41(T)-4                           | --                             | --             |
| SGF-51(T)-5  | --                   | YC-065                    | --         | --         | --                  | --                                  | --                                  | LGF-51(T)-5<br>LGF-51(T)-5A           | --                             | --             |
| SGHD-002GA-P0.2  | YRS-1590             | --                        | --         | --         | --                  | --                                  | --                                  | --                                    | --                             | --             |
| SGM-51T-5  | --                   | YC-056                    | --         | --         | --                  | --                                  | --                                  | LGM-51T-5                             | --                             | --             |
| SGVH-002T-P0.2   | YRS-1590             | --                        | --         | --         | --                  | --                                  | --                                  | --                                    | --                             | --             |
| SHCM-A03T-P025   | YRS-960              | --                        | --         | --         | --                  | --                                  | WC-SHCM-A03                         | --                                    | --                             | --             |
| SHF-001T-0.8BS   | YRS-122              | YC-122R                   | --         | --         | --                  | --                                  | WC-122                              | BHF-001T-0.8BS                        | EJ-SMP (Note1)                 | --             |
| SHF-002T-0.8BS   | YRS-300              | --                        | --         | --         | --                  | --                                  | --                                  | --                                    | EJ-SMP (Note1)                 | --             |
| SHIF-01T-P0.5  | --                   | YC-985R                   | --         | --         | --                  | --                                  | --                                  | --                                    | EJ-HILP                        | --             |
| SHIF-21T-P0.5  | --                   | YC-995R                   | --         | --         | --                  | --                                  | --                                  | --                                    | EJ-HILP                        | --             |
| SHIM-01T-P0.5  | --                   | YC-985R                   | --         | --         | --                  | --                                  | --                                  | --                                    | EJ-HILR                        | --             |
| SHIM-21T-P0.5  | --                   | YC-995R                   | --         | --         | --                  | --                                  | --                                  | --                                    | EJ-HILR                        | --             |
| SHR-001T-P0.6  | YRS-580              | YC-580R                   | --         | --         | --                  | --                                  | --                                  | BHR-001T-P0.6                         | --                             | --             |
| SHYVF-21T-M0.5   | --                   | --                        | --         | --         | --                  | --                                  | --                                  | --                                    | EJ-BNI                         | --             |
| SHYVF-41T-M0.5   | --                   | --                        | --         | --         | --                  | --                                  | --                                  | --                                    | EJ-BNI                         | --             |
| SIM-01(T)-110A   | --                   | YC-054                    | --         | --         | --                  | --                                  | --                                  | LIM-01(T)-110A                        | --                             | --             |
| SIM-1.0-250D/N   | --                   | --                        | --         | --         | --                  | --                                  | JUCS-IM                             | --                                    | --                             | --             |
| SIM-2.5-250D/N   | --                   | --                        | --         | --         | --                  | --                                  | JUCS-IM                             | --                                    | --                             | --             |
| SIM-41(T)-110B   | --                   | YC-067                    | --         | --         | --                  | --                                  | --                                  | LIM-41(T)-110B                        | --                             | --             |
| SIM-51(T)-250N   | --                   | YC-321                    | --         | --         | --                  | --                                  | --                                  | LIM-51(T)-250N                        | --                             | --             |

Note 1: Please use EJ-SMP as an extraction tool when using the combination with SM connector 18-circuit housing.  
2: Contact JST for wire range.

Crimping tools

| Terminals and parts model number in alphabetical order | Hand tools          |                           |            |            |                     | Hand tools                          |                                     |                                   | Extraction and Insertion tools |                |
|--|---------------------|---------------------------|------------|------------|---------------------|-------------------------------------|-------------------------------------|-----------------------------------|--------------------------------|----------------|
|  | for chain terminals | for loose piece terminals |            |            |                     | for loose piece terminals           |                                     |                                   | Extraction tool                | Insertion tool |
|  | YRS series          | YC series                 | YRM series | YRF series | YRK · YRK-EX series | WC & JUC series<br>JUK's Hand Tools | Terminal in loose form<br>model No. |                                   |                                |                |
| SIN-001T-1.2   | YRS-034             | --                        | --         | --         | --                  | --                                  | --                                  | --                                | --                             | --             |
| SIN-002T-1.0S  | YRS-035             | --                        | --         | --         | --                  | --                                  | --                                  | --                                | --                             | --             |
| SIN-01T-1.2  | --                  | YC-340R                   | --         | --         | --                  | --                                  | --                                  | LIN-01T-1.2                       | --                             | --             |
| SIN-01T-1.8  | --                  | YC-032                    | --         | --         | --                  | --                                  | --                                  | LIN-01T-1.8                       | --                             | --             |
| SIN-01T-1.8N   | --                  | YC-032                    | --         | --         | --                  | --                                  | --                                  | LIN-01T-1.8N                      | --                             | --             |
| SIN-21T-1.8  | --                  | YC-350                    | --         | --         | --                  | --                                  | --                                  | LIN-21T-1.8                       | --                             | --             |
| SIN-21T-1.8S   | --                  | YC-570<br>YC-571          | --         | --         | --                  | --                                  | --                                  | LIN-21T-1.8S                      | --                             | --             |
| SIN-61T-2.6S   | --                  | YC-560                    | --         | --         | --                  | --                                  | --                                  | LIN-61T-2.6S                      | --                             | --             |
| SIN-81T-3.6S   | --                  | YC-940                    | --         | --         | --                  | --                                  | --                                  | LIN-81T-3.6S                      | --                             | --             |
| SIN-91T-4.7S   | --                  | --                        | --         | --         | YRK-1630            | --                                  | --                                  | --                                | --                             | --             |
| SJ2F-002GF-P1.0<br>SJ2M-002GF-M1.0N                    | YRS-8851            | --                        | --         | --         | YRK-8851            | --                                  | --                                  | --                                | EJ-JFAJ2N                      | --             |
| SJ2F-01GF-P1.0<br>SJ2M-01GF-M1.0N<br>SJ2M-01GF-M1.0S   | YRS-8861            | --                        | --         | --         | YRK-8861            | --                                  | --                                  | --                                | EJ-JFAJ2N                      | --             |
| SJ2F-21GF-P1.0<br>SJ2M-21GF-M1.0N                      | --                  | --                        | --         | YRF-1120   | YRK-1120            | --                                  | --                                  | LJ2F-21GF-P1.0<br>LJ2M-21GF-M1.0N | EJ-JFAJ2N                      | --             |
| SJ3F-002GF-P1.8  | --                  | --                        | --         | YRF-882    | --                  | --                                  | --                                  | --                                | --                             | --             |
| SJ3F-01GF-P1.8   | --                  | --                        | --         | YRF-881    | --                  | --                                  | --                                  | --                                | --                             | --             |
| SJ3F-41GF-P1.8   | --                  | --                        | --         | YRF-880    | --                  | --                                  | --                                  | --                                | --                             | --             |
| SJ4F-71GF-M3.0   | --                  | --                        | --         | YRF-1130   | --                  | --                                  | --                                  | BJ4F-71GF-M3.0                    | EJ-JFAJ4                       | --             |
| SJ4F-81GF-M3.0   | --                  | --                        | --         | YRF-1370   | --                  | --                                  | --                                  | BJ4F-81GF-M3.0                    | EJ-JFAJ4                       | --             |
| SJ5F-71GF-M6.5<br>SJ5M-71GF-M6.5                       | --                  | --                        | --         | YRF-888    | --                  | --                                  | --                                  | BJ5F-71GF-M6.5<br>BJ5M-71GF-M6.5  | EJ-JFAJ5                       | --             |
| SJ5F-81GF-M6.5<br>SJ5M-81GF-M6.5                       | --                  | --                        | --         | YRF-889    | --                  | --                                  | --                                  | LJ5F-81GF-M6.5<br>LJ5M-81GF-M6.5  | EJ-JFAJ5                       | --             |
| SJ5F-91GF-M6.5<br>SJ5M-91GF-M6.5                       | --                  | --                        | --         | --         | --                  | --                                  | --                                  | LJ5F-91GF-M6.5<br>LJ5M-91GF-M6.5  | EJ-JFAJ5                       | --             |
| SJFPS-81T-M1.0   | --                  | --                        | --         | YRF-1610   | --                  | --                                  | --                                  | --                                | --                             | --             |
| SJN-001PT-0.9  | YRS-1181            | --                        | --         | --         | --                  | --                                  | --                                  | --                                | --                             | --             |
| SJN-002PT-0.9  | YRS-036             | --                        | --         | --         | --                  | --                                  | --                                  | --                                | --                             | --             |
| SJWPSR-21T-P1.0<br>SJWPST-21T-M1.0N                    | --                  | --                        | --         | --         | --                  | --                                  | --                                  | --                                | EJ-JWPS-RT                     | --             |
| SLC-21T-2.0  | --                  | YC-310                    | --         | --         | --                  | --                                  | WC-310                              | LLC-21T-2.0                       | --                             | --             |
| SLC-001T-P2.0  | --                  | --                        | --         | --         | --                  | --                                  | --                                  | --                                | EJ-LCL                         | --             |
| SLC-02T-P2.0   | --                  | --                        | --         | --         | --                  | --                                  | --                                  | --                                | EJ-LCL                         | --             |
| SLF-01T-P1.3E<br>SLM-01T-P1.3E                         | --                  | YC-202                    | YRM-201    | --         | --                  | --                                  | WC-202                              | LLF/M-01T-P1.3E                   | LEJ-13                         | LIT-2013       |
| SLF-41T-P1.3E<br>SLM-41T-P1.3E                         | --                  | YC-203                    | --         | --         | --                  | --                                  | WC-203                              | LLF/M-41T-P1.3E                   | LEJ-13                         | --             |
| SMF-01T-1.0  | --                  | YC-081                    | --         | --         | --                  | --                                  | --                                  | LMF-01T-1.0                       | --                             | --             |
| SMF-01T-1.3  | --                  | YC-082                    | --         | --         | --                  | --                                  | --                                  | LMF-01T-1.3                       | --                             | --             |
| SMM-003T-P0.5  | YRS-800             | --                        | --         | --         | --                  | --                                  | WC-800                              | --                                | --                             | --             |
| SMR-001T-0.6   | YRS-580             | YC-580R                   | --         | --         | --                  | --                                  | --                                  | BMR-001T-0.6                      | --                             | --             |
| SOM-21(T)-187  | --                  | YC-680                    | --         | --         | --                  | --                                  | --                                  | LOM-21(T)-187                     | --                             | --             |
| SOM-51(T)-250  | --                  | YC-066                    | --         | --         | --                  | --                                  | WC-066                              | LOM-51(T)-250                     | --                             | --             |
| SOTZP-002GD-P0.18                                      | --                  | --                        | --         | --         | --                  | --                                  | --                                  | --                                | EJ-OTZS                        | --             |

Note: Contact JST for wire range.

Crimping tools

| Terminals and parts model number in alphabetical order | Hand tools          |                           |            |            |                     | Hand tools                          |                                  |                 | Extraction and Insertion tools |                |
|--|---------------------|---------------------------|------------|------------|---------------------|-------------------------------------|----------------------------------|-----------------|--------------------------------|----------------|
|  | for chain terminals | for loose piece terminals |            |            |                     | for loose piece terminals           |                                  |                 | Extraction tool                | Insertion tool |
|  | YRS series          | YC series                 | YRM series | YRF series | YRK · YRK-EX series | WC & JUC series<br>JUK's Hand Tools | Terminal in loose form model No. |                 |                                |                |
| SPA-001T-P0.5  | —                   | YC-610R<br>YC-611R        | —          | —          | —                   | —                                   | —                                | BPA-001T-P0.5   | EJ-PH                          | —              |
| SPAL-001T-P0.5   | —                   | YC-610R<br>YC-611R        | —          | —          | —                   | —                                   | —                                | BPAL-001T-P0.5  | EJ-PAL                         | —              |
| SPAL-002T-P0.5   | YRS-1340            | —                         | —          | —          | —                   | —                                   | —                                | —               | EJ-PAL                         | —              |
| SPB-1.0-250N-S   | —                   | —                         | —          | —          | —                   | —                                   | JUCS-PB                          | —               | —                              | —              |
| SPB-2.5-250N-S   | —                   | —                         | —          | —          | —                   | —                                   | JUCS-PB                          | —               | —                              | —              |
| SPBD-001T-P0.5   | —                   | YC-610R                   | —          | —          | —                   | —                                   | —                                | —               | —                              | —              |
| SPBD-002T-P0.5   | —                   | YC-611R                   | —          | —          | —                   | —                                   | —                                | —               | —                              | —              |
| SPF-01T-2.5C   | —                   | YC-043R                   | —          | —          | —                   | —                                   | —                                | LPF-01T-2.5C    | —                              | —              |
| SPH-001T-P0.5L   | YRS-245             | —                         | —          | —          | —                   | —                                   | —                                | —               | —                              | —              |
| SPH-002T-P0.5L   | YRS-241             | —                         | —          | —          | —                   | —                                   | —                                | —               | EJ-PH                          | —              |
| SPH-002T-P0.5S   | YRS-240             | —                         | YRM-240    | —          | —                   | —                                   | WC-240                           | BPH-002T-P0.5S  | EJ-PH                          | —              |
| SPH-004T-P0.5S   | YRS-243             | —                         | —          | —          | —                   | —                                   | —                                | —               | EJ-PH                          | —              |
| SPHD-001T-P0.5   | —                   | YC-610R<br>YC-611R        | —          | —          | —                   | —                                   | WC-610                           | BPHD-001T-P0.5  | EJ-PHD-RB                      | —              |
| SPHD-002T-P0.5   | YRS-620             | —                         | YRM-620    | —          | —                   | —                                   | WC-620                           | BPHD-002T-P0.5  | EJ-PHD-RB                      | —              |
| SPID-001T-P0.5   | YRS-1620            | —                         | —          | —          | —                   | —                                   | —                                | —               | EJ-PID                         | —              |
| SPLI-002T-P0.5   | YRS-1410            | —                         | —          | —          | —                   | —                                   | —                                | —               | —                              | —              |
| SPND-001T-C0.5   | YRS-1091            | —                         | —          | —          | —                   | —                                   | —                                | —               | EJ-PND                         | —              |
| SPND-002T-C0.5   | YRS-1090            | —                         | —          | —          | —                   | —                                   | —                                | —               | EJ-PND                         | —              |
| SPNI-001T-P0.5   | —                   | YC-610R<br>YC-611R        | —          | —          | —                   | —                                   | —                                | —               | —                              | —              |
| SPNI-002T-P0.5   | YRS-1340            | —                         | —          | —          | —                   | —                                   | —                                | —               | —                              | —              |
| SPS-01T-110  | —                   | YC-740                    | —          | —          | —                   | —                                   | WC-740                           | LPS-01T-110     | —                              | —              |
| SPS-01T-187(-8)  | —                   | YC-730<br>YC-731          | —          | —          | —                   | —                                   | WC-730                           | LPS-01T-187(-8) | EJ-PS187                       | —              |
| SPS-21T-205(-5)  | —                   | YC-760                    | —          | —          | —                   | —                                   | —                                | LPS-21T-205(-5) | —                              | —              |
| SPS-21T-250  | —                   | YC-780                    | —          | —          | —                   | —                                   | WC-780                           | LPS-21T-250     | EJ-PS250                       | —              |
| SPS-21T-250S   | —                   | YC-780                    | —          | —          | —                   | —                                   | WC-780                           | LPS-21T-250S    | EJ-PS250                       | —              |
| SPS-21T-250R   | —                   | YC-780                    | —          | —          | —                   | —                                   | —                                | LPS-21T-250R    | EJ-PS250                       | —              |
| SPS-41T-110  | —                   | YC-750<br>YC-751          | —          | —          | —                   | —                                   | WC-750                           | LPS-41T-110     | —                              | —              |
| SPS-51T-187(-8)  | —                   | YC-710<br>YC-711          | —          | —          | —                   | —                                   | WC-710                           | LPS-51T-187(-8) | EJ-PS187                       | —              |
| SPS-51T-205  | —                   | YC-770<br>YC-771          | —          | —          | —                   | —                                   | —                                | LPS-51T-205     | —                              | —              |
| SPS-61T-250  | —                   | YC-720                    | —          | —          | —                   | —                                   | WC-720                           | LPS-61T-250     | EJ-PS250                       | —              |
| SPS-61T-250S   | —                   | YC-720                    | —          | —          | —                   | —                                   | —                                | LPS-61T-250S    | EJ-PS250                       | —              |
| SPS-61T-250R   | —                   | YC-721                    | —          | —          | —                   | —                                   | —                                | LPS-61T-250R    | EJ-PS250                       | —              |
| SPS-91T-250  | —                   | —                         | —          | YRF-790    | —                   | —                                   | —                                | BPS-91T-250     | EJ-PS250                       | —              |
| SPS-91T-250S   | —                   | —                         | —          | YRF-790    | —                   | —                                   | —                                | BPS-91T-250S    | EJ-PS250                       | —              |
| SPS-91T-250R   | —                   | —                         | —          | YRF-791    | —                   | —                                   | —                                | BPS-91T-250R    | EJ-PS250                       | —              |
| SPSI-001T-M1.1   | —                   | YC-335R                   | —          | —          | —                   | —                                   | —                                | —               | EJ-PSIP                        | —              |
| SPSM-001T-M1.1   | —                   | YC-335R                   | —          | —          | —                   | —                                   | —                                | —               | EJ-PSIR                        | —              |
| SPSI-41T-M1.1  | —                   | YC-225R                   | —          | —          | —                   | —                                   | —                                | —               | EJ-PSIP                        | —              |
| SPSM-41T-M1.1  | —                   | YC-226R                   | —          | —          | —                   | —                                   | —                                | —               | EJ-PSIR                        | —              |
| SPUD-001T-P0.5   | YRS-1320            | —                         | —          | —          | —                   | —                                   | —                                | —               | EJ-PUD                         | —              |
| SPUD-002T-P0.5   | YRS-1520            | —                         | —          | —          | —                   | —                                   | —                                | —               | EJ-PUD                         | —              |

Note: Contact JST for wire range.

Crimping tools

| Terminals and parts model number in alphabetical order | Hand tools           |                           |            |            |                     | Hand tools                          |                                     |                                  | Extraction and Insertion tools |                |
|--|----------------------|---------------------------|------------|------------|---------------------|-------------------------------------|-------------------------------------|----------------------------------|--------------------------------|----------------|
|  | for chain terminals  | for loose piece terminals |            |            |                     | for loose piece terminals           |                                     |                                  | Extraction tool                | Insertion tool |
|  | YRS series           | YC series                 | YRM series | YRF series | YRK · YRK-EX series | WC & JUC series<br>JUK's Hand Tools | Terminal in loose form<br>model No. |                                  |                                |                |
| SPXA-001T-P0.6   | --                   | --                        | --         | --         | --                  | --                                  | --                                  | --                               | EJ-PXA                         | --             |
| SRA-20(T)**  | --                   | YC-181                    | --         | --         | --                  | --                                  | --                                  | LRA-20(T)**                      | --                             | --             |
| SRA-21(T)**  | --                   | YC-141                    | --         | --         | --                  | --                                  | --                                  | LRA-21(T)**                      | --                             | --             |
| SRA-50(T)**  | --                   | YC-182                    | --         | --         | --                  | --                                  | --                                  | LRA-50(T)**                      | --                             | --             |
| SRA-51(T)**  | --                   | YC-142                    | --         | --         | --                  | --                                  | --                                  | LRA-51(T)**                      | --                             | --             |
| SRB-1.0( )   | --                   | --                        | --         | --         | --                  | --                                  | JUCS-RB/RT                          | --                               | --                             | --             |
| SRB-2.5( )   | --                   | --                        | --         | --         | --                  | --                                  | JUCS-RB/RT                          | --                               | --                             | --             |
| SRB-51(T)**  | --                   | YC-142                    | --         | --         | --                  | --                                  | --                                  | LRB-51(T)**                      | --                             | --             |
| SRC-01(T)**  | --                   | YC-033                    | --         | --         | --                  | --                                  | --                                  | LRC-01(T)**                      | --                             | --             |
| SRC-50(T)**  | --                   | YC-183                    | --         | --         | --                  | --                                  | --                                  | LRC-50(T)**                      | --                             | --             |
| SRC-51(T)**  | --                   | YC-142                    | --         | --         | --                  | --                                  | --                                  | LRC-51(T)**                      | --                             | --             |
| SRF-51(T)**  | --                   | YC-142                    | --         | --         | --                  | --                                  | --                                  | LRF-51(T)**                      | --                             | --             |
| SRFCP-002GG-M0.9                                       | YRS-1530<br>YRS-1531 | --                        | --         | --         | --                  | --                                  | --                                  | --                               | EJ-RFC-P                       | --             |
| SRFF-01GG-S0.9   | --                   | --                        | --         | --         | --                  | --                                  | --                                  | --                               | EJ-RFC-R                       | --             |
| SRFF-61GG-S0.9   | --                   | --                        | --         | YRF-1450   | --                  | --                                  | --                                  | --                               | EJ-RFC-R                       | --             |
| SRFM-01GG-S0.9   | --                   | --                        | --         | --         | --                  | --                                  | --                                  | --                               | EJ-RPZ                         | --             |
| SRFM-61GG-S0.9   | --                   | --                        | --         | YRF-1450   | --                  | --                                  | --                                  | --                               | EJ-RPZ                         | --             |
| SRICM-61GG-S0.6  | --                   | YC-840R                   | --         | --         | --                  | --                                  | --                                  | --                               | --                             | --             |
| SRICM-61T-S0.6   | --                   | --                        | --         | --         | --                  | --                                  | --                                  | --                               | --                             | --             |
| SRT-1.0( )   | --                   | --                        | --         | --         | --                  | --                                  | JUCS-RB/RT                          | --                               | --                             | --             |
| SRT-2.5( )   | --                   | --                        | --         | --         | --                  | --                                  | JUCS-RB/RT                          | --                               | --                             | --             |
| SRT-51T**  | --                   | YC-143R                   | --         | --         | --                  | --                                  | --                                  | LRT-51T**                        | --                             | --             |
| SRWF-01GG-M0.6   | --                   | --                        | --         | --         | --                  | --                                  | --                                  | --                               | EJ-RPZ                         | --             |
| SRWF-01T-M0.6  | --                   | --                        | --         | --         | --                  | --                                  | --                                  | --                               | --                             | --             |
| SRWM-01GG-S0.6   | --                   | --                        | --         | --         | --                  | --                                  | --                                  | --                               | EJ-RPZ                         | --             |
| SRWF-21GG-M0.6   | --                   | --                        | --         | --         | --                  | --                                  | --                                  | --                               | EJ-RPZ                         | --             |
| SRWF-21GG-S0.6   | --                   | --                        | --         | --         | --                  | --                                  | --                                  | --                               | --                             | --             |
| SRWF-61GG-M0.6   | --                   | YC-840R                   | --         | --         | --                  | --                                  | --                                  | BRWF-61GG-M0.6<br>BRWM-61GG-S0.6 | EJ-RPZ                         | --             |
| SRWF-61T-M0.6  | --                   | --                        | --         | --         | --                  | --                                  | --                                  | --                               | --                             | --             |
| SRWM-61GG-S0.6   | --                   | --                        | --         | --         | --                  | --                                  | --                                  | --                               | --                             | --             |
| SSFH-001T-P0.5   | YRS-1580<br>YRS-1581 | --                        | --         | --         | --                  | --                                  | --                                  | --                               | EJ-SFH                         | --             |
| SSFH-002T-P0.5   | YRS-1490             | --                        | --         | --         | --                  | --                                  | --                                  | --                               | EJ-SFH                         | --             |
| SSH-003T-P0.2-H  | YRS-859              | --                        | --         | --         | --                  | --                                  | WC-SH2832                           | --                               | --                             | --             |
| SSH-003GA-P0.2   | YRS-859              | --                        | --         | --         | --                  | --                                  | WC-SH2832                           | --                               | --                             | --             |
| SSHJ-003T-P0.2   | YRS-859              | --                        | --         | --         | --                  | --                                  | --                                  | --                               | --                             | --             |
| SSHL-002T-P0.2   | YRS-1590             | --                        | --         | --         | --                  | --                                  | WC-GH2630                           | --                               | --                             | --             |
| SSHL-003T-P0.2   | YRS-859              | --                        | --         | --         | --                  | --                                  | WC-SH2832                           | --                               | --                             | --             |
| SSHL-003GA1-P0.2                                       | YRS-859              | --                        | --         | --         | --                  | --                                  | WC-SH2832                           | --                               | --                             | --             |
| SSF-01T-P1.4   | --                   | YC-500                    | --         | --         | --                  | --                                  | --                                  | BSF/M-01T-P1.4                   | SLJ-1.4                        | ITBL-08V       |
| SSM-01T-P1.4   | --                   | --                        | --         | --         | --                  | --                                  | --                                  | --                               | --                             | --             |
| SSF-21T-P1.4   | --                   | YC-550                    | --         | --         | --                  | --                                  | WC-550                              | BSF/M-21T-P1.4                   | SLJ-1.4                        | --             |
| SSM-21T-P1.4   | --                   | --                        | --         | --         | --                  | --                                  | --                                  | --                               | --                             | --             |
| STI-01(T)-110N   | --                   | YC-041                    | --         | --         | --                  | --                                  | --                                  | LTI-01(T)-110N                   | --                             | --             |
| STI-1.0-250D/N   | --                   | --                        | --         | --         | --                  | --                                  | JUCS-TI                             | --                               | --                             | --             |
| STI-2.5-250D/N   | --                   | --                        | --         | --         | --                  | --                                  | JUCS-TI                             | --                               | --                             | --             |
| STI-41(T)-110N   | --                   | YC-063                    | --         | --         | --                  | --                                  | --                                  | LTI-41(T)-110N                   | --                             | --             |
| STI-51(T)-250N   | --                   | YC-322                    | --         | --         | --                  | --                                  | --                                  | LTI-51(T)-250N                   | --                             | --             |
| STO-01(T)-110N(-8)                                     | --                   | YC-041                    | --         | --         | --                  | --                                  | --                                  | LTO-01(T)-110N(-8)               | --                             | --             |
| STO-01(T)-187N(-8)                                     | --                   | YC-042                    | --         | --         | --                  | --                                  | --                                  | LTO-01(T)-187N(-8)               | --                             | --             |

Note: Contact JST for wire range.

Crimping tools

| Terminals and parts model number in alphabetical order | Hand tools          |                               |                          |            |                     | Hand tools                          |                                     | Extraction and Insertion tools |                |
|--|---------------------|-------------------------------|--------------------------|------------|---------------------|-------------------------------------|-------------------------------------|--------------------------------|----------------|
|  | for chain terminals | for loose piece terminals     |                          |            |                     | for loose piece terminals           |                                     | Extraction tool                | Insertion tool |
|  | YRS series          | YC series                     | YRM series               | YRF series | YRK · YRK-EX series | WC & JUC series<br>JUK's Hand Tools | Terminal in loose form<br>model No. |                                |                |
| STO-0.25-110N  | --                  | YC-810                        | --                       | --         | --                  | --                                  | --                                  | --                             | --             |
| STO-0.5-110N   | --                  | YC-820                        | --                       | --         | --                  | JUCS-05110                          | --                                  | --                             | --             |
| STO-1.0-110N   | --                  | --                            | --                       | --         | --                  | JUCS-2.8/4.8                        | --                                  | --                             | --             |
| STO-1.0-187N   | --                  | --                            | --                       | --         | --                  | JUCS-2.8/4.8                        | --                                  | --                             | --             |
| STO-1.0-250N   | --                  | --                            | --                       | --         | --                  | JUCS-6.3                            | --                                  | --                             | --             |
| STO-2.5-250N   | --                  | --                            | --                       | --         | --                  | JUCS-6.3                            | --                                  | --                             | --             |
| STO-21(T)-205N(-5)                                     | --                  | YC-053                        | --                       | --         | --                  | --                                  | LTO-21(T)-205N                      | --                             | --             |
| STO-21(T)-250N   | --                  | YC-102                        | --                       | --         | --                  | --                                  | LTO-21(T)-250N                      | --                             | --             |
| STO-41(T)-110N(-8)                                     | --                  | YC-062                        | --                       | --         | --                  | --                                  | LTO-41(T)-110N(-8)                  | --                             | --             |
| STO-41(T)-187N(-8)                                     | --                  | YC-051                        | --                       | --         | --                  | --                                  | LTO-41(T)-187N(-8)                  | --                             | --             |
| STO-41T-187S   | --                  | YC-064                        | --                       | --         | --                  | --                                  | LTO-41T-187S                        | EJ-187S                        | --             |
| STO-61(T)-250N   | --                  | YC-047                        | --                       | --         | --                  | --                                  | LTO-61(T)-250N                      | --                             | --             |
| STO-81(T)-250N   | --                  | YC-280                        | --                       | YRF-280    | --                  | --                                  | LTO-81(T)-250N                      | --                             | --             |
| STS-002GG-P0.6<br>STSD-002GG-P0.6                      | YRS-1360            | --                            | --                       | --         | --                  | --                                  | --                                  | EJ-TSD                         | --             |
| SVA-41T-P1.1   | --                  | YC-450                        | --                       | --         | --                  | --                                  | BVA-41T-P1.1                        | --                             | --             |
| SVF-01T-1.5A   | --                  | YC-044                        | --                       | --         | --                  | --                                  | LVF-01T-1.5A                        | --                             | --             |
| SVF-01T-1.5N   | --                  | YC-151                        | --                       | --         | --                  | --                                  | LVF-01T-1.5N                        | EJ-SV                          | --             |
| SVF-01T-2.36N  | --                  | YC-152                        | --                       | --         | --                  | --                                  | LVF-01T-2.36N                       | EJ-LV                          | --             |
| SVF-42T-P2.0   | --                  | YC-592                        | --                       | --         | --                  | WC-592                              | BVF-42T-P2.0                        | VLJ-20                         | --             |
| SVM-42T-P2.0   | --                  | YC-593                        | --                       | --         | --                  | WC-592                              | BVM-42T-P2.0                        | VLJ-20                         | --             |
| SVF-61T-P0.2<br>SVM-61T-P0.2                           | --                  | YC-590                        | --                       | YRF-590    | --                  | WC-590                              | BVF/M-61T-P2.0                      | VLJ-20                         | --             |
| SVF-81T-P0.2<br>SVM-81T-P0.2                           | --                  | --                            | --                       | YRF-591    | --                  | WC-591                              | BVF/M-81T-P2.0                      | VLJ-20                         | --             |
| SVH-21T-P1.1   | --                  | YC-160R<br>YC-161R<br>YC-164R | YRM-160<br>--<br>YRM-164 | --         | --                  | WC-160                              | BVH-21T-(P)1.1                      | EJ-NV                          | --             |
| SVH-41T-P1.1   | --                  | YC-930R<br>YC-931R            | --                       | --         | --                  | WC-930                              | BVH-41T-P1.1                        | EJ-NV                          | --             |
| SVSF-61T-S2.0<br>SVSM-61T-S2.0                         | --                  | --                            | --                       | YRF-590    | --                  | --                                  | --                                  | VLJ-20                         | --             |
| SVSF-81T-S2.0<br>SVSM-81T-S2.0                         | --                  | --                            | --                       | YRF-591    | --                  | --                                  | --                                  | VLJ-20                         | --             |
| SVT-41T-P1.1   | --                  | YC-630                        | --                       | --         | --                  | --                                  | BVT-41T-P1.1                        | EJ-VT                          | --             |
| SVU-21T-P0.6   | --                  | YC-990R                       | --                       | --         | --                  | --                                  | BVU-21T-P0.6                        | EJ-VU                          | --             |
| SVYF-61T-P0.5A   | --                  | --                            | --                       | YRF-536    | --                  | --                                  | --                                  | --                             | --             |
| SWPJT-21T-P0.5   | --                  | --                            | --                       | --         | --                  | --                                  | --                                  | EJ-WPJ                         | --             |
| SWPJT-21T-P0.5A  | --                  | --                            | --                       | --         | --                  | --                                  | --                                  | EJ-WPJ                         | --             |
| SWPJR-21T-M0.5   | --                  | --                            | --                       | --         | --                  | --                                  | --                                  | EJ-WPJ                         | --             |
| SWPKP-21T-0.6  | --                  | --                            | --                       | YRF-1051   | --                  | --                                  | BWPKP-21T-0.6                       | --                             | --             |
| SWPKR-21T-0.6  | --                  | --                            | --                       | YRF-1050   | --                  | --                                  | BWPKR-21T-0.6                       | --                             | --             |
| SWPR-001T-P025<br>SWPT-001T-P025                       | YRS-980             | --                            | --                       | --         | --                  | WC-JWPF                             | --                                  | EJ-JWPF                        | --             |
| SXA-01T-P0.6   | YRS-701             | YC-701R                       | --                       | --         | --                  | WC-700M                             | BXA-01T-P0.6                        | EJ-XAG, EJ-XMP                 | --             |
| SXA-001T-P0.6  | YRS-692             | YC-692R                       | --                       | --         | --                  | --                                  | BXA-001T-P0.6                       | EJ-XMP, EJ-XMR                 | IT-XA          |
| SXA-001T-P0.6L   | YRS-691             | --                            | --                       | --         | --                  | WC-691                              | --                                  | --                             | --             |

Note: Contact JST for wire range.

Crimping tools

| Terminals and parts model number in alphabetical order | Hand tools          |                           |            |            |                     | Hand tools                          |                                     |                                 | Extraction and Insertion tools |                |
|--|---------------------|---------------------------|------------|------------|---------------------|-------------------------------------|-------------------------------------|---------------------------------|--------------------------------|----------------|
|  | for chain terminals | for loose piece terminals |            |            |                     | for loose piece terminals           |                                     |                                 | Extraction tool                | Insertion tool |
|  | YRS series          | YC series                 | YRM series | YRF series | YRK · YRK-EX series | WC & JUC series<br>JUK's Hand Tools | Terminal in loose form<br>model No. |                                 |                                |                |
| SXAM-01T-P0.6  | YRS-701             | YC-701R                   | —          | —          | —                   |                                     | WC-700M                             | BXAM-01T-P0.6                   | EJ-XAW                         | —              |
| SXAM-001T-P0.6   | YRS-692             | YC-692R                   | —          | —          | —                   |                                     | —                                   | BXAM-001T-P0.6                  | EJ-XAW                         | —              |
| SXF-01T-P0.7   | —                   | YC-251                    | —          | —          | —                   |                                     | —                                   | BXF-01T-(P)0.7                  | LEJ-7                          | —              |
| SXF-41T-P0.7   | —                   | YC-252                    | —          | —          | —                   |                                     | —                                   | BXF-41T-(P)0.7                  | LEJ-7                          | —              |
| SXH-001T-P0.6  | YRS-110             | YC-110R<br>YC-111R        | —          | —          | —                   |                                     | WC-110                              | BXH-001T-P0.6                   | XJ-06                          | —              |
| SXH-001T-P0.6N   | —                   | —                         | —          | —          | —                   |                                     | —                                   | —                               | XJ-06                          | —              |
| SXH-002T-P0.6  | YRS-480             | —                         | —          | —          | —                   |                                     | —                                   | —                               | XJ-06                          | —              |
| SXM-01T-P0.6   | YRS-701             | YC-701R                   | —          | —          | —                   |                                     | —                                   | BXM-01T-P0.6                    | EJ-XAG, EJ-XMP                 | —              |
| SXM-001T-P0.6  | YRS-692             | YC-692R                   | —          | —          | —                   |                                     | —                                   | BXM-001T-P0.6                   | EJ-XMP, EJ-XMR                 | IT-XA          |
| SXNI-001T-P0.6   | YRS-1380            | —                         | —          | —          | —                   |                                     | —                                   | —                               | —                              | —              |
| SXNI-003T-P0.6   | YRS-1390            | —                         | —          | —          | —                   |                                     | —                                   | —                               | —                              | —              |
| SYF-001T-P0.6  | YRS-125             | —                         | —          | —          | —                   |                                     | —                                   | —                               | —                              | —              |
| SYF-01T-P0.5A  | —                   | YC-520                    | —          | —          | —                   |                                     | WC-520                              | BYF-01T-P0.5A<br>BYM-01T-P0.5A  | YLJ-0.5                        | —              |
| SYF-41T-P0.5A  | —                   | YC-530                    | —          | —          | —                   |                                     | WC-530                              | BYF-41T-P0.5A<br>BYM-41T-P0.5A  | YLJ-0.5                        | —              |
| SYF-61T-P0.5A  | —                   | —                         | —          | YRF-536    | —                   |                                     | —                                   | —                               | —                              | —              |
| SYM-001T-P0.6  | YRS-121             | YC-121R                   | —          | —          | —                   |                                     | WC-121                              | BYM-001T-P0.6                   | SMJ-06                         | —              |
| SYM-01T-P0.7   | —                   | YC-251                    | —          | —          | —                   |                                     | —                                   | BYM-01T-(P)0.7                  | LEJ-7                          | —              |
| SYM-41T-P0.7   | —                   | YC-252                    | —          | —          | —                   |                                     | —                                   | BYM-41T-(P)0.7                  | LEJ-7                          | —              |
| SZE-002T-P0.3  | YRS-1460            | —                         | —          | —          | —                   |                                     | —                                   | —                               | —                              | —              |
| SZE-003T-P0.3  | YRS-1330            | —                         | —          | —          | —                   |                                     | —                                   | —                               | —                              | —              |
| SZF-01T-P0.7   | —                   | YC-390R                   | —          | —          | —                   |                                     | —                                   | BZF-01T-(P)07<br>BZM-01T-(P)0.7 | ZLJ-0.7S                       | —              |
| SZF-41T-P0.7   | —                   | YC-380R                   | —          | —          | —                   |                                     | —                                   | BZF-41T-(P)07<br>BZM-41T-(P)0.7 | ZLJ-0.7S                       | —              |
| SZH-002T-P0.5  | YRS-491             | —                         | —          | —          | —                   |                                     | WC-491                              | —                               | —                              | —              |
| SZH-003T-P0.5  | YRS-490             | —                         | —          | —          | —                   |                                     | WC-490                              | —                               | —                              | —              |
| SZN-002T-P0.7K   | YRS-541             | —                         | —          | —          | —                   |                                     | —                                   | —                               | —                              | —              |
| SZN-003T-P0.7K   | YRS-540             | —                         | —          | —          | —                   |                                     | —                                   | —                               | —                              | —              |
| SZND-002T-P0.5   | YRS-1710            | —                         | —          | —          | —                   |                                     | —                                   | —                               | —                              | —              |
| SZPD-002T-P0.3   | YRS-1460            | —                         | —          | —          | —                   |                                     | —                                   | —                               | —                              | —              |

Note : Contact JST for wire range.



**YRK series hand crimping tools suitable for mass-production**

- Crimping work, such as setting contacts to hand tools etc., is facilitated by using a strip contact to improve the productivity.
- A light operation enables to terminate the contact correctly, by adopting straight-ahead crimping.
- A structure, that the carrier of contact doesn't fly off, has been adopted to this tool.

**Hand Crimping Tools**

**YRK Standard type**

- When exchanging the crimper, the crimping suitable for the wire specification can be conducted.
- Anvil is fixed to tool.



Dimensions: 75(W)×314(L)×25(D) mm  
Weight: Approx. 800 g (When assembling dies)

**Contact and Applicable dies**

| Series | Nominal         | Contact Model No. |                                      | Hand crimp tools   | Model No. of crimper <sup>*1</sup> | Applicable wire size |                      |                      |
|--------|-----------------|-------------------|--------------------------------------|--------------------|------------------------------------|----------------------|----------------------|----------------------|
|        |                 | Receptacle        | Tab                                  |                    |                                    | Marking              | AWG                  | Insulation O.D. (mm) |
| J1000  | M               | SF1F-002(*)-P0.6  | SF1M-002(*)-M0.6A                    | YRK-1220           | MA / MB                            | MA                   | #28                  | φ 1.20               |
|        |                 |                   |                                      |                    |                                    | MB                   | #24                  | φ 1.43               |
|        | ME              | SF1F-01GC-P0.6    | SF1M-01GC-M0.6A                      | YRK-1230           | MEA / MEB<br>MEC / MED             | MEA                  | #24                  | φ 1.43               |
|        |                 |                   |                                      |                    |                                    | MEB                  | #20                  | φ 1.76               |
|        |                 |                   |                                      |                    |                                    | MEC                  | #22                  | φ 1.58               |
|        |                 |                   |                                      |                    |                                    | MED                  | #22                  | φ 1.36 <sup>*5</sup> |
| L      | SF1F-21(*)-P0.6 | SF1M-21(*)-M0.6A  | YRK-1210                             | LA / LB<br>LC / LD | LA                                 | #22                  | φ 1.58               |                      |
|        |                 |                   |                                      |                    | LB                                 | KV0.75               | φ 1.90               |                      |
|        |                 |                   |                                      |                    | LC                                 | #20                  | φ 1.76               |                      |
|        |                 |                   |                                      |                    | LD                                 | #18                  | φ 2.03               |                      |
| J2000  | S               | SJ2F-002(*)-P1.0  | SJ2M-002(*)-M1.0N                    | YRK-8852           | SA / SB<br>SC / SD                 | SA                   | #28                  | φ 1.20               |
|        |                 |                   |                                      |                    |                                    | SB                   | #24                  | φ 1.43               |
|        |                 |                   |                                      |                    |                                    | SD                   | #24                  | φ 1.11 <sup>*3</sup> |
|        | M               | SJ2F-01(*)-P1.0   | SJ2M-01(*)-M1.0N<br>SJ2M-01(*)-M1.0S | YRK-8863           | MA / MB<br>MC / MD                 | MA                   | #24                  | φ 1.43               |
|        |                 |                   |                                      |                    |                                    | MB                   | #20                  | φ 1.53 <sup>*2</sup> |
|        |                 |                   |                                      |                    |                                    | MD                   | #22                  | φ 1.26 <sup>*3</sup> |
| J300   | L               | SJ2F-21(*)-P1.0   | SJ2M-21(*)-M1.0N<br>SJ2M-21(*)-M1.0S | YRK-1120           | LA / LB                            | LA                   | #22                  | φ 1.58               |
|        |                 |                   |                                      |                    |                                    | LB                   | #20                  | φ 1.76               |
|        | S               | SF3F-002(*)-P2.0  | SF3M-002(*)-M2.0N                    | YRK-8821           | SA / SB<br>SC / SD                 | SA                   | #28                  | φ 1.20               |
|        |                 |                   |                                      |                    |                                    | SB                   | #24                  | φ 1.43               |
|        |                 |                   |                                      |                    |                                    | SD                   | #24                  | φ 1.11               |
|        | M               | SF3F-01(*)-P2.0   | SF3M-01(*)-M2.0N                     | YRK-8811           | MA / MB<br>MC / MD                 | MA                   | #24                  | φ 1.43               |
| MB     |                 |                   |                                      |                    |                                    | #20                  | φ 1.76               |                      |
| MC     |                 |                   |                                      |                    |                                    | #22                  | φ 1.58               |                      |
| MD     |                 |                   |                                      |                    |                                    | #20                  | φ 2.56 <sup>*4</sup> |                      |
| L      | SF3F-41(*)-P2.0 | SF3M-41(*)-M2.0N  | YRK-8801                             | LA / LB<br>LC / LD | LA                                 | #20                  | φ 1.76               |                      |
|        |                 |                   |                                      |                    | LB                                 | #16                  | φ 2.35               |                      |
|        |                 |                   |                                      |                    | LC                                 | #18                  | φ 2.03               |                      |
|        |                 |                   |                                      |                    | LD                                 | #18                  | φ 2.83 <sup>*4</sup> |                      |
| 2L     | SF3F-71(*)-P2.0 | SF3M-71(*)-M2.0N  | YRK-1071                             | 2LA / 2LB          | 2LA                                | #16                  | φ 3.10 <sup>*4</sup> |                      |
|        |                 |                   |                                      |                    | 2LB                                | KIV2.0               | φ 3.30               |                      |

Note: 1. Surface Finish(\*) GC...Nickel-undercoated, 0.2μm selective gold-plated  
GF...Nickel-undercoated, 0.38μm selective gold-plated  
GFA...Nickel-undercoated, 0.38μm selective gold-plated (A type)  
GI...Nickel-undercoated, 0.76μm selective gold-plated  
GIA...Nickel-undercoated, 0.76μm selective gold-plated (A type)  
T...Tin-plated (reflow treatment)

\*1... Crimper is either the pair of A and B or the pair of C and D.  
\*2... When using wire type UL 2517.  
\*3... When using wire type 1061  
\*4... When using wire type 1015  
\*5... When using wire type 10442

2. The wear of parts is caused by using hand tool repeatedly.  
Measure the crimping height daily and conduct periodical inspection of the wearing parts, such as ratchet, pin and so on.

**Dies replacement type hand crimping tools**

**YRK-EX**

- High reliability of crimping is provided by choosing the crimper and anvil suitable for the wire specification.
- The crimping die can be easily exchanged by only insertion and extraction of pin.
- Common handle and crimping dies can be stored in One case and it is easy to carry.

Patent pending

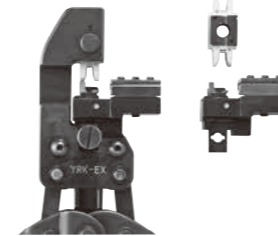

Dimensions: 75(W)×314(L)×25(D) mm  
Weight: Approx. 800 g (When assembling dies)



Dimensions: 376×295(L)×73(D) mm

**Contact and Applicable dies**

| Series | Nominal         | Contact Model No.                    |                                      | Crimper <sup>*1</sup><br>Model No. | Applicable wire size |                      |                      | Anvil  | Color mark   | Common parts                                  |
|--------|-----------------|--------------------------------------|--------------------------------------|------------------------------------|----------------------|----------------------|----------------------|--------|--------------|---|
|        |                 | Receptacle                           | Tab                                  |                                    | Die mark             | AWG                  | Insulation O.D. (mm) |        |              |   |
| J1000  | M               | SF1F-002(*)-M0.6A                    | SF1M-002(*)-M0.6A                    | J1MA / B<br>J1MC / D               | J1MA                 | #28                  | φ 1.20               | J1ML   | Gold         | Handle unit<br>Upper pin<br>Lower pin<br>Case |
|        |                 |                                      |                                      |                                    | J1MB                 | #24                  | φ 1.43               |        |              |   |
|        |                 |                                      |                                      |                                    | J1MC                 | #26                  | φ 1.30               |        |              |   |
|        | L               | SF1F-21(*)-P0.6                      | SF1M-21(*)-M0.6A                     | J1LA / B<br>J1LC / D               | J1MD                 | #24                  | φ 1.11               | J1LL   | Yellow green |   |
|        |                 |                                      |                                      |                                    | J1LA                 | #20                  | φ 1.76               |        |              |   |
|        |                 |                                      |                                      |                                    | J1LB                 | #18                  | φ 2.03               |        |              |   |
| J2000  | S               | SJ2F-002(*)-P1.0                     | SJ2M-002(*)-M1.0N                    | J2SA / B<br>J2SC / D               | J2SA                 | #28                  | φ 1.20               | J2SL   | White        |   |
|        |                 |                                      |                                      |                                    | J2SB                 | #24                  | φ 1.43               |        |              |   |
|        |                 |                                      |                                      |                                    | J2SC                 | #26                  | φ 1.30               |        |              |   |
|        | M               | SJ2F-01(*)-P1.0                      | SJ2M-01(*)-M1.0N<br>SJ2M-01(*)-M1.0S | J2MA / B<br>J2MC / D               | J2SD                 | #24                  | φ 1.11 <sup>*3</sup> | J2ML   | Purple       |   |
|        |                 |                                      |                                      |                                    | J2MA                 | #24                  | φ 1.43               |        |              |   |
|        |                 |                                      |                                      |                                    | J2MB                 | #20                  | φ 1.53 <sup>*2</sup> |        |              |   |
| L      | SJ2F-21(*)-P1.0 | SJ2M-21(*)-M1.0N<br>SJ2M-21(*)-M1.0S | J2LA / B                             | J2MC                               | #24                  | φ 1.11 <sup>*3</sup> | J2LL                 | Orange |              |   |
|        |                 |                                      |                                      | J2MD                               | #22                  | φ 1.26 <sup>*3</sup> |                      |        |              |   |
|        |                 |                                      |                                      | J2LA                               | #22                  | φ 1.58               |                      |        |              |   |
|        |                 |                                      |                                      | J2LB                               | #20                  | φ 1.76               |                      |        |              |   |
| J300   | S               | SF3F-002(*)-P2.0                     | SF3M-002(*)-M2.0N                    | J3SA / B<br>J3SC / D               | J3SA                 | #28                  | φ 1.20               | J3SL   | Yellow       |   |
|        |                 |                                      |                                      |                                    | J3SB                 | #24                  | φ 1.43               |        |              |   |
|        |                 |                                      |                                      |                                    | J3SC                 | #26                  | φ 1.30               |        |              |   |
|        | M               | SF3F-01(*)-P2.0                      | SF3M-01(*)-M2.0N                     | J3MA / B<br>J3MC / D               | J3SD                 | #24                  | φ 1.11               | J3ML   | Green        |   |
|        |                 |                                      |                                      |                                    | J3MA                 | #24                  | φ 1.43               |        |              |   |
|        |                 |                                      |                                      |                                    | J3MB                 | #20                  | φ 1.76               |        |              |   |
| L      | SF3F-41(*)-P2.0 | SF3M-41(*)-M2.0N                     | J3LA / B<br>J3LC / D                 | J3MC                               | #22                  | φ 1.58               | J3LL                 | Red    |              |   |
|        |                 |                                      |                                      | J3MD                               | #20                  | φ 2.56 <sup>*4</sup> |                      |        |              |   |
|        |                 |                                      |                                      | J3LA                               | #20                  | φ 1.76               |                      |        |              |   |
|        |                 |                                      |                                      | J3LB                               | #16                  | φ 2.35               |                      |        |              |   |
| 2L     | SF3F-71(*)-P2.0 | SF3M-71(*)-M2.0N                     | J32LA / B                            | J3LC                               | #18                  | φ 2.03               | J32LL                | Blue   |              |   |
|        |                 |                                      |                                      | J3LD                               | #18                  | φ 2.83 <sup>*4</sup> |                      |        |              |   |
|        |                 |                                      |                                      |                                    | J32LA                | #16                  | φ 3.10 <sup>*4</sup> |        |              |   |
|        |                 |                                      |                                      |                                    | J32LB                | KIV2.0               | φ 3.30               |        |              |   |

Note: 1. Surface Finish(\*) : GC...Nickel-undercoated, 0.2μm selective gold plated  
GF...Nickel-undercoated, 0.38μm selective gold-plated  
GFA...Nickel-undercoated, 0.38μm selective gold-plated (A type)  
GI...Nickel-undercoated, 0.76μm selective gold-plated  
GIA...Nickel-undercoated, 0.76μm selective gold-plated (A type)  
T...Tin-plated

\*1... Crimper is either the pair of A and B or the pair of C and D.  
\*2... When using wire type UL 2517.  
\*3... When using wire type 1061.  
\*4... When using wire type 1015.

2. The wear of parts is caused by using hand tool repeatedly.  
Measure the crimping height daily and conduct periodical inspection of the wearing parts, such as ratchet, pin and so on.