

SYMBOL DEFINITION		TOTAL NO OF INSPECTIONS REQUIRED		MISSING SYMBOLS	
A	DIMENSION WITHOUT AN INSPECTION REPORT SYMBOL DOES NOT REQUIRE INSPECTION. IT MAY BE CONTROLLED ON THE INDIVIDUAL COMPONENT DRAWING.			4	NO MISSING SYMBOL NUMBER
			LAST NO. USED	4	

DWS STATUS						REVISION HISTORY						AUTH		DR		APVD	
DATE	STG	REV	N/P	CHG	ZONE												
21AUB8	R	01	-	-		13663718, 13663719, 13663720, 13669835, 13690836, 13690837, 13697414, 13697415, 13697416, 13697417, 13697418 & 13697419	RELEASED					401819	END	END	RP		
145E09	R	02	-	-		ALL PARTS - DIM #3 WAS Ø 2.55 +0.15/0						408872	MRF	MRF	PGD		
03ND09	R	03	-	-		ALL PARTS - ADDED LUBRICATION NOTE						409310	JOA	FRG	PGD		
08FE11	R	04	-	-		13867872 - RELEASED						413249	AJP	JAA	GER		
28FE11	R	05	-	-		ALL PARTS - ADDED TERMINAL NOTES						413480	HRS	HRS	PGD		
30MY11	R	06	-	-		ALL PARTS - ADDED ASSEMBLY NOTE						414411	JTZ	JTZ	PGD		
08JN11	R	07	-	-		ALL PARTS - UPDATED PDM ATTRIBUTES						414458	AGM	JAA	PGD		
05SE11	R	08	-	-		ALL PARTS - REVISED NOTES						415281	CBG	CBG	PGD		
13OC11	R	09	-	-		ALL PARTS - ADDED TERMINAL APPLICATION INFORMATION NOTE						415775	JCF	JVM	PGD		
30JA13	R	10	-	-		ALL PARTS - UPDATED PDM ATTRIBUTES						421285	IMF	JVM	PGD		

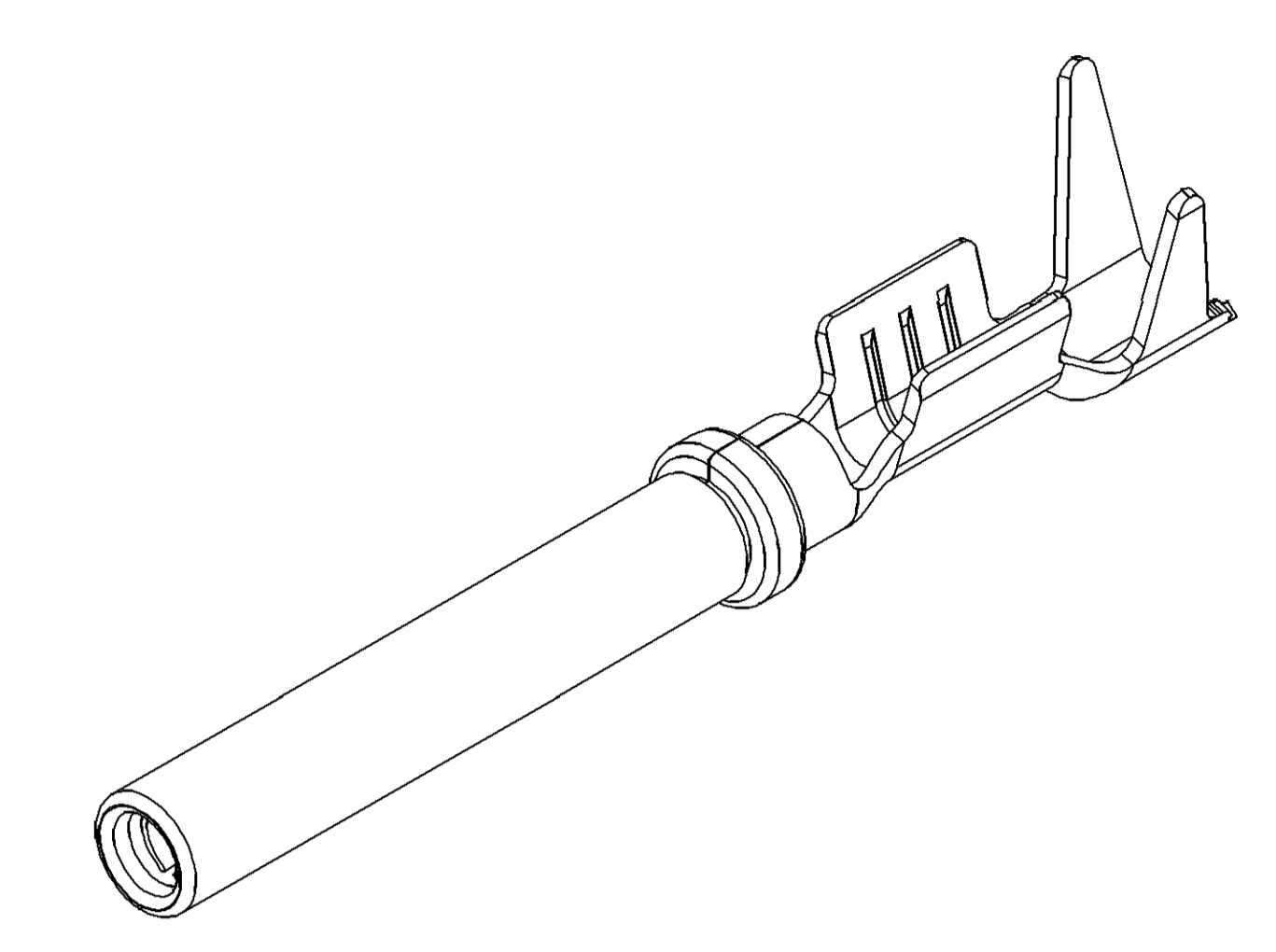

- NOTES**
- UNLESS OTHERWISE SPECIFIED AND/OR INDICATED:
DIMENSIONS ARE TO FACE OF VIEW SHOWN AND AUTOMATICALLY ROUNDED BY COMPUTER FOR INSPECTION (SEE MATH MODEL FOR PRECISE DIMENSIONS). FOR ALL OTHER DIMENSIONS NOT SHOWN BUT REQUIRED FOR TOOL BUILD, SEE MATH MODEL FOR PRECISE TOOL PATH DATA.
 - TERMINAL MUST BE MADE BY APPLYING NYE 1486 LUBE OIL OR EQUIVALENT (PREFERRED WITH A FLUORESCENT TRACE ADDED). AFTER STAMPING (OR FINAL PROCESS PRIOR TO SHIPPING) NYE 1486 MUST BE PRESENT ON THE MATING INTERFACE AREA AND ON THE OUTSIDE SURFACE OF THE CORE CRIMP WINGS. THE RECOMMENDED APPLICATION METHOD RATE UTILIZES A QUANTITY OF 0.75 GALLONS MINIMUM PER 1 MILLION TERMINALS. ANY OTHER LUBRICANT MUST BE APPROVED BY DELPHI CONNECTION SYSTEMS PRODUCT ENGINEERING. THE NYE 1486 OIL CAN ALSO BE APPLIED DURING THE STAMPING OPERATION AT A RATE OF 50% NYE 1486 AND 50% FIN LUBE 177 (SUPPLIED BY PPG).
 - DO NOT PROBE, TEST OR OTHERWISE CONTACT THE INTERIOR REGION (THE SPRING OR ANY MOVING PART) OF THIS TERMINAL. SEVERE DAMAGE CAN OCCUR, COMPROMISING THE PERFORMANCE OF THE ELECTRICAL INTERFACE.
 - TERMINAL CAN BE USED IN ANY 1.0 MM (SIZE 20 MIL 39029) INDUSTRY STANDARD CAVITY. EXAMPLE DEUTSCH DTM
 - TERMINAL IS A DIRECT REPLACEMENT FOR (EQUIVALENT TO) THE DEUTSCH 1062-20-XXX FAMILY OF STAMPED AND FORMED CONTACTS
 - REFER TO DRAWING NUMBER 13922721 FOR TERMINAL APPLICATION INFORMATION (CURRENT CARRYING CAPABILITY, CABLE CRIMP RANGE, ETC.)

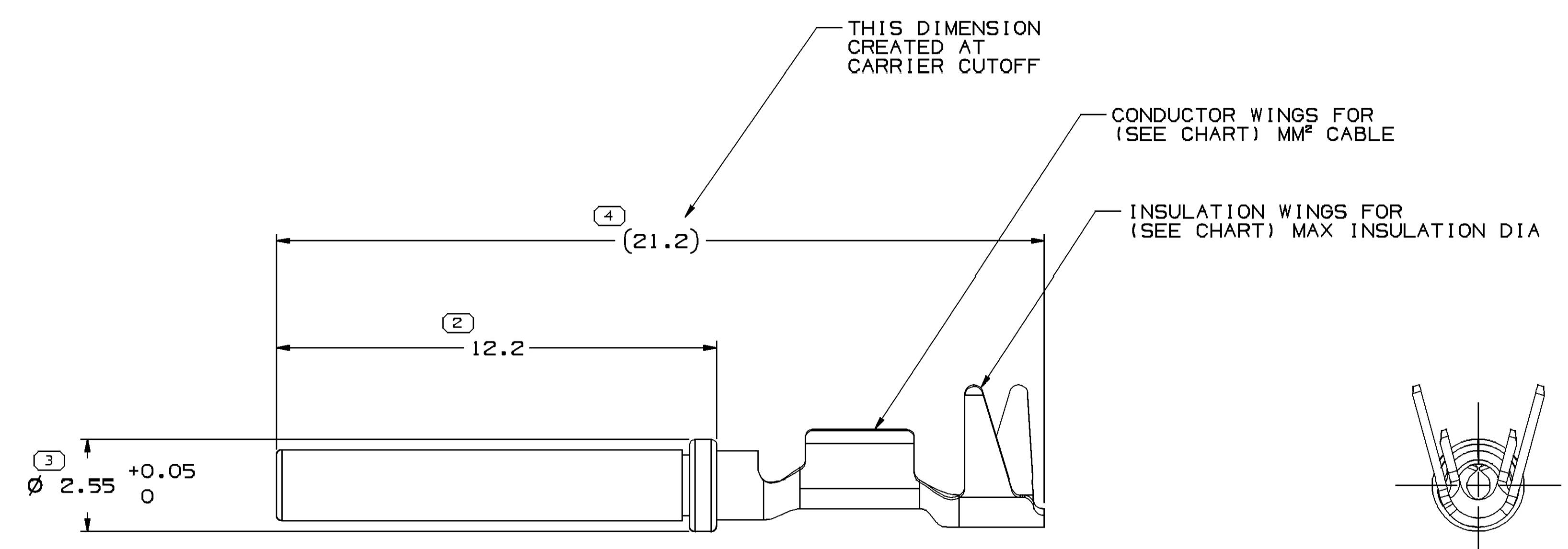
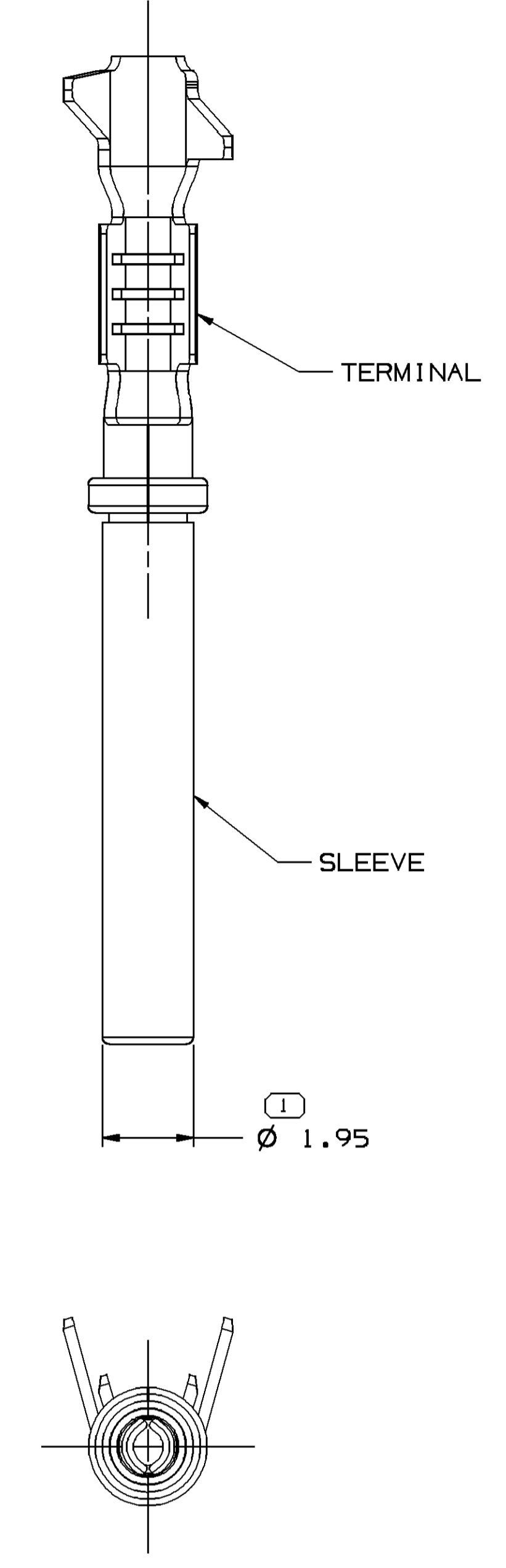
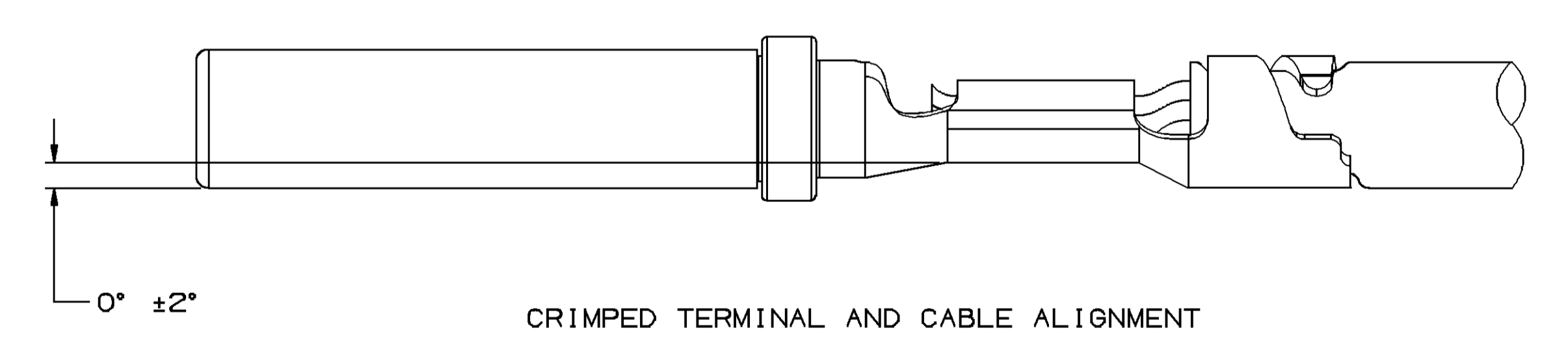

- MATERIAL NOTES :**
- TERMINAL: COPPER ALLOY - 0.254 THK
SLEEVE: STAINLESS STEEL - 0.13 THK
- ASSEMBLY NOTES:**
- SLEEVE MUST WITHSTAND PULL-OFF FORCE IN DIRECTION PARALLEL TO CENTER OF TERMINAL OF 60 NEWTONS MIN.

PART NO	REV	N/P	CONTACT PLATING	SIZE (MM²)	ID	DIA	MATING TERM
13867872	01	AF	SILVER	0.35-0.5	21T	1.25-1.8	NA
13711549	01	AH	GOLD	0.75-1	17T	1.6-2.25	13711545
13711548	01	AH	NICKEL	0.75-1	17T	1.6-2.25	13711544
13711547	01	AH	GOLD	0.35-0.5	21T	1.25-1.8	13711543
13711546	01	AH	NICKEL	0.35-0.5	21T	1.25-1.8	13711542
13663728	01	AH	GOLD	0.75-1	17	2.05-2.78	13663724
13663727	01	AH	NICKEL	0.75-1	17	2.05-2.78	13663723
13654422	01	AH	GOLD	0.35-0.5	21	1.8-2.51	13654424
13654421	01	AH	NICKEL	0.35-0.5	21	1.8-2.51	13654423

DELPHI
DELPHI PACKARD ELECTRICAL/ELECTRONIC ARCHITECTURE
WARREN, OH
COPYRIGHT 2008 DELPHI CORPORATION AND/OR ITS AFFILIATES. ALL RIGHTS RESERVED.
THIS DRAWING IS THE PROPERTY OF DELPHI CORPORATION AND CONTAINS DELPHI CONFIDENTIAL INFORMATION. THE REPRODUCTION, DISTRIBUTION AND UTILIZATION OF THIS DOCUMENT OR ITS CONTENTS OR DATA, AS WELL AS COMMUNICATION OF ANY CONTENT TO OTHERS, WITHOUT EXPRESS AUTHORIZATION, IS PROHIBITED.

DATE

OR

APVD1 E. NEAL DUNHAM 21AUB8
APVD2 E. NEAL DUNHAM 21AUB8
APVD3 R. POLENICK 21AUB8
APVD4
APVD5

SUBSTANCES OF CONCERN AND RECYCLED CONTENT PER DELPHI (09-4490)

MATERIAL

SEE MATERIAL NOTES

DRAWING NAME

TAXI ASM TERM F HES 1.0

DRAWING NUMBER

13663726

SIZE

A0 10:1 1 OF 1 1 OF 1 R 10 -

APPROVALS

APPROVED BY: [Signature]

DATE: 01-FEB-13

Mouser Electronics

Authorized Distributor

Click to View Pricing, Inventory, Delivery & Lifecycle Information:

[Aptiv:](#)

[13711546-L](#) [13711547-L](#) [13711548-L](#) [13654421-L](#) [13654422-L](#) [13663727-L](#)