

LOC		DIST		REVISIONS			
P	LTR	DESCRIPTION		DATE	DWN	APVD	
AD	00	P1		REVISED PER ECO-11-004587	11MAR11	RK	HMR

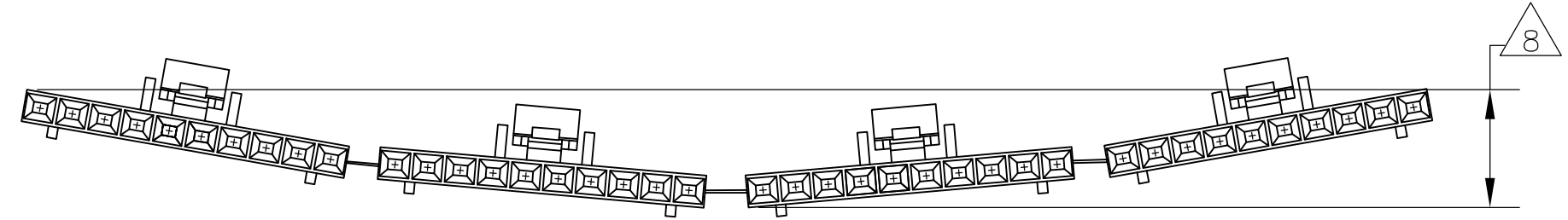
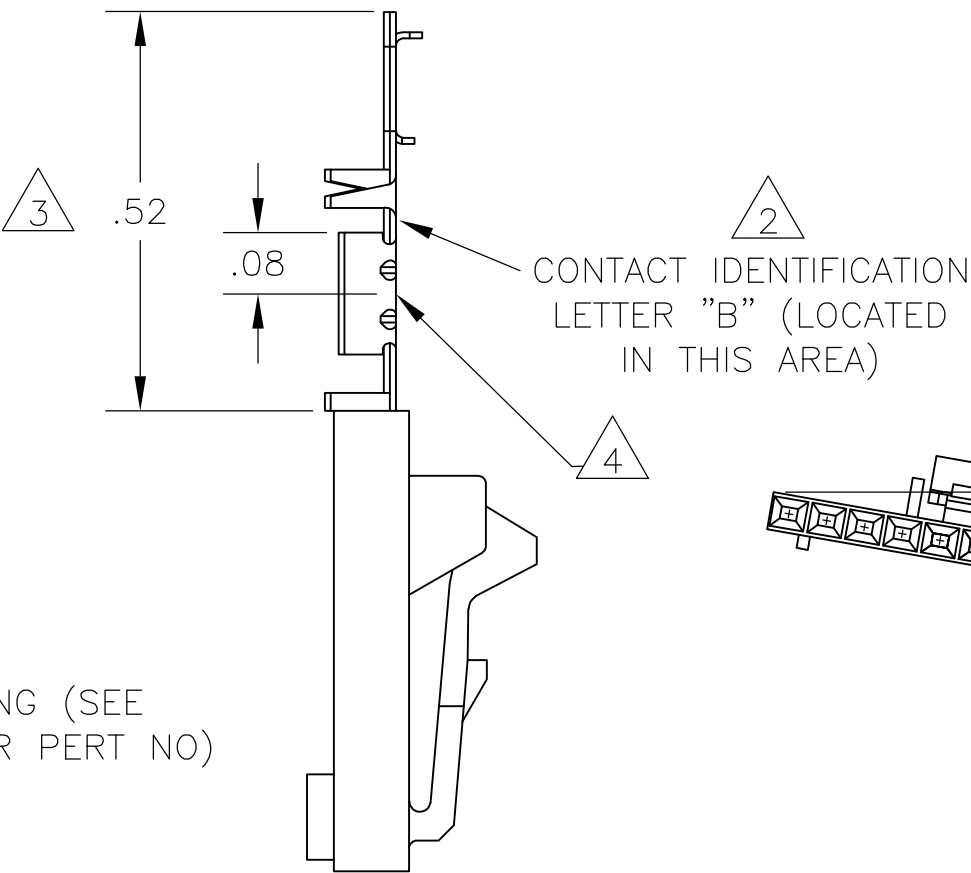
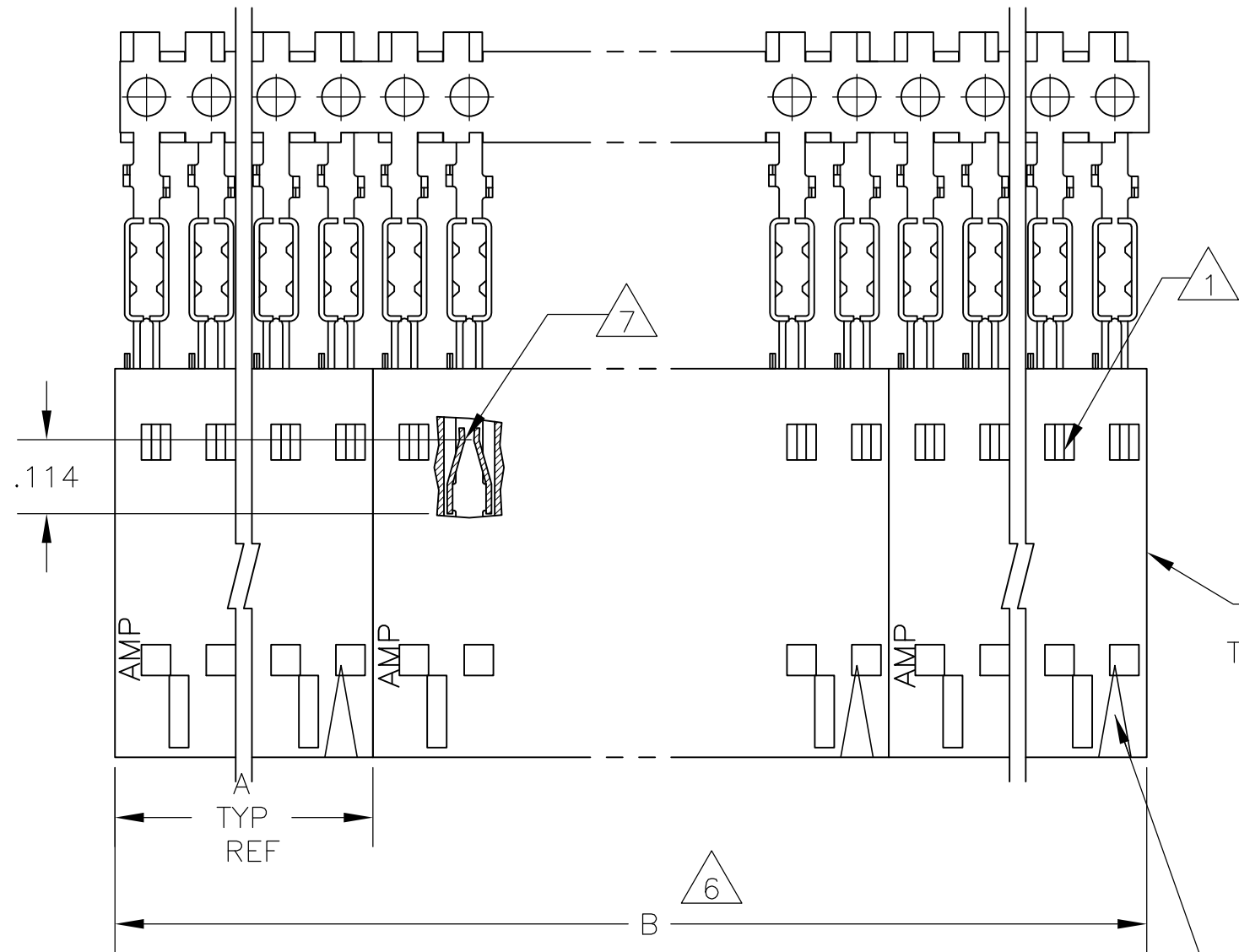

EXAMPLE: STRIP ASSEMBLY
SCALE 2:1

12	2	2.40	1.198	1-104257-1	12	6-103958-1
12	2	2.20	1.098	1-104257-0	11	6-103958-0
12	2	2.00	.998	104257-9	10	5-103958-9
12	2	1.80	.898	104257-8	9	5-103958-8
12	2	1.60	.798	104257-7	8	5-103958-7
12	2	1.40	.698	104257-6	7	5-103958-6
12	4	2.39	.598	104257-5	6	5-103958-5
12	4	1.99	.498	104257-4	5	5-103958-4
12	5	1.99	.398	104257-3	4	5-103958-3
12	8	2.40	.298	104257-2	3	5-103958-2
12	10	2.00	.198	104257-1	2	5-103958-1
10	2	1.60	.798	104257-7	8	1-103958-6
10	4	1.99	.498	104257-4	5	1-103958-5
10	5	1.99	.398	104257-3	4	1-103958-4
10	8	2.40	.298	104257-2	3	1-103958-3
10	10	2.00	.198	104257-1	2	1-103958-2
9	2	2.40	1.198	1-104257-1	12	1-103958-1
9	2	2.20	1.098	1-104257-0	11	1-103958-0
9	2	2.00	.998	104257-9	10	103958-9
9	2	1.80	.898	104257-8	9	103958-8
9	2	1.60	.798	104257-7	8	103958-7
9	2	1.40	.698	104257-6	7	103958-6
9	4	2.39	.598	104257-5	6	103958-5
9	4	1.99	.498	104257-4	5	103958-4
9	5	1.99	.398	104257-3	4	103958-3
9	8	2.40	.298	104257-2	3	103958-2
9	10	2.00	.198	104257-1	2	103958-1
PLATING	△6	B	A	HOUSING PART NUMBER	NO OF POSN	ASSEMBLY PART NUMBER ON STRIP

THIS DRAWING IS A CONTROLLED DOCUMENT.		DWN	L A MAYER	11-4-86	TE Connectivity	
DIMENSIONS: INCHES		CHK	P de Jong	11-12-86		
TOLERANCES UNLESS OTHERWISE SPECIFIED:		APVD	P de Jong	11-12-86		
0 PLC ± - 1 PLC ± - 2 PLC ± .02 3 PLC ± .005 4 PLC ± - ANGLES ± - FINISH SEE TABLE		NAME	RCPT ASSY, AMPMODU MTE, SINGLE ROW, .100 C/L, LATCHED & POLARIZED, FOR NO 22-NO 26 AWG WIRE SIZE, STRIP FORM			
MATERIAL	HOUSING:	PRODUCT SPEC	108-25034		SIZE	A2
		APPLICATION SPEC	114-25026		CAGE CODE	00779
		WEIGHT	-		DRAWING NO	C=103958
		CUSTOMER DRAWING			RESTRICTED TO	-
		SCALE	4:1		SHEET	1 of 1
		REV	P1			

- △1 CONTACTS ARE LATCHED INTO THE PRELOAD WINDOWS
- △2 USE WITH #22-#26 AWG WIRE SIZE, .054/.030 INSULATION DIAMETER, .015 MAXIMUM INSULATION THICKNESS
- △3 THE DIMENSION APPLIES WITH THE FORWARD PRELOAD STOP IN CONTACT WITH THE HOUSING SURFACE
- △4 POINT OF MEASUREMENT FOR PLATING THICKNESS
- 5 FOR INDIVIDUAL ASSEMBLIES SEE PART NUMBER 103734
- △6 ASSEMBLIES ARE JOINED BY THE CARRIER STRIP. ORDER QUANTITY REFLECTS TOTAL NUMBER OF INDIVIDUAL ASSEMBLIES REQUIRED. SEE TABLE FOR NUMBER OF ASSEMBLIES PER STRIP.
- △7 POINT OF MEASUREMENT FOR PLATING THICKNESS (INSIDE BEAMS)
- △8 MAXIMUM ALLOWABLE BOW OF ASSEMBLY NOT TO EXCEED .055.
- △9 .000030 GOLD IN THE CONTACT AREA. .000050-.000100 BRIGHT TIN-LEAD ON THE TERMINATION AREA, ALL OVER .000050 NICKEL.
- △10 .000030 GOLD IN THE CONTACT AREA. .000050-.000100 BRIGHT TIN ON THE TERMINATION AREA, ALL OVER .000050 NICKEL.
- △11 PRELIMINARY PART - NOT RELEASED FOR PRODUCTION.
- △12 .000030 GOLD IN THE CONTACT AREA, .000050 - .000100 MATTE TIN ON THE TERMINATION AREA, ALL OVER .000050 NICKEL

Mouser Electronics

Authorized Distributor

Click to View Pricing, Inventory, Delivery & Lifecycle Information:

[TE Connectivity:](#)

[103958-3](#)