

THIS DOCUMENT IS THE PROPERTY OF KEYSTONE ELECTRONICS CORP. AND SHALL NOT BE REPRODUCED, DISTRIBUTED OR USED AS A BASIS FOR MANUFACTURE WITHOUT PRIOR WRITTEN PERMISSION FROM KEYSTONE ELECTRONICS CORP.

MOUNTING DETAIL

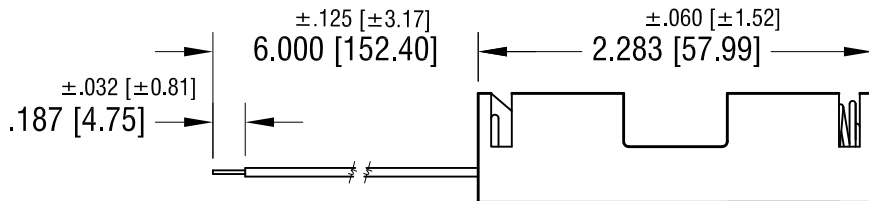
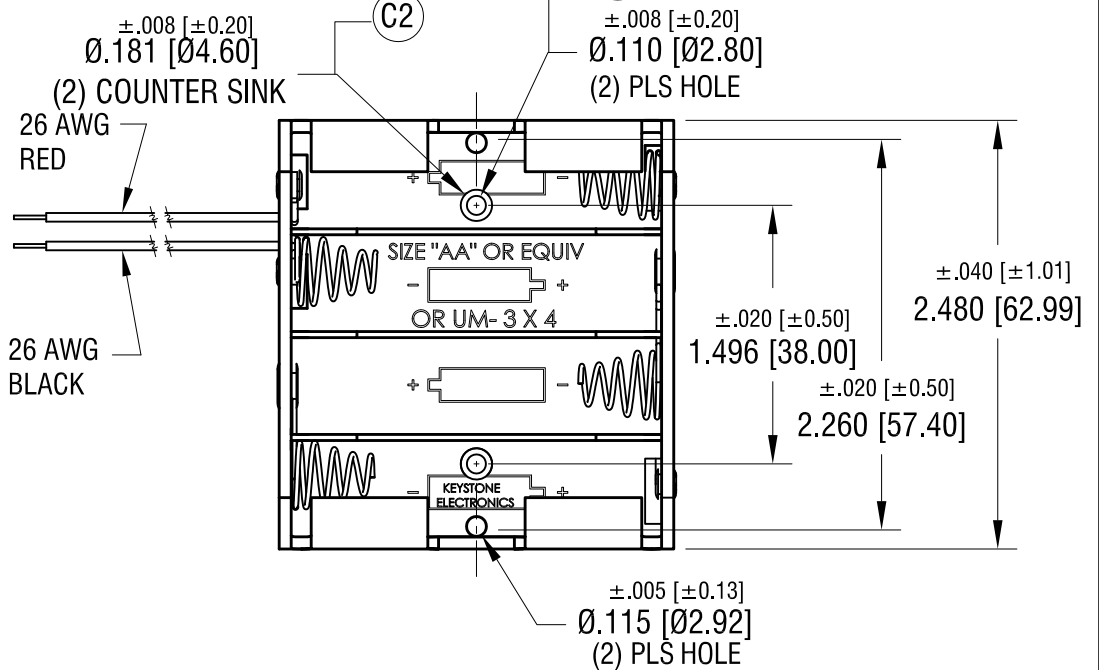
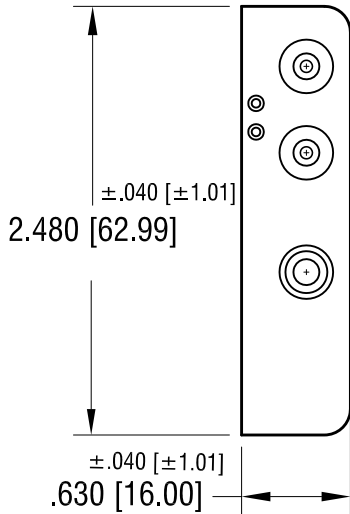
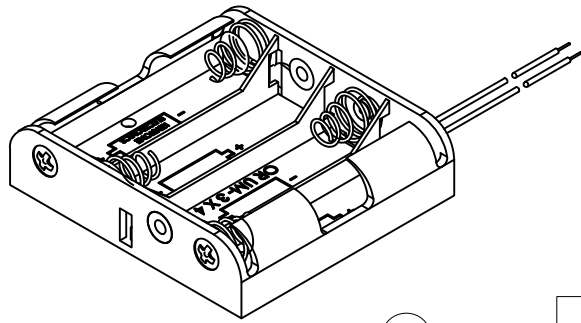
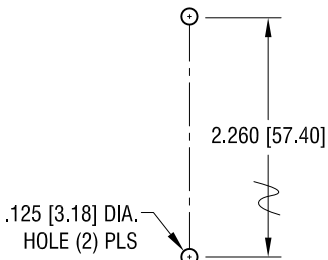

NOTE:

- 1. HOLDER: MAT'L: POLYPROPYLENE
- SPRING: MAT'L: MUSIC WIRE, .027 [0.70] DIA.
- FINISH: NICKEL PLATE

**KEYSTONE ELECTRONICS CORP.**

www.keyelco.com • NEW HYDE PARK, NY 11040 • Tel (516) 328-7500

PART NAME		BATTERY HOLDER (4) 'AA'	
MATERIAL		AS NOTE	
FINISH	AS NOTED	DRN BY	BOONE
		APP'D	LN
		DATE	3.1.99
		SCALE	.9X
TOLERANCES	INCH [MM]	CODE	DWG NO.
DECIMAL	± .015 [± 0.38]	C	2478
ANGULAR	± 1°		
UNLESS OTHERWISE SPECIFIED			

3.26.19	ADD (C1) AND (C2) CHANGE AS PER ECN 19-040	C
9.13.08	CHANGE AS PER ECN 08-154	B
11.10.99	CHANGE AS PER ECN 99-082	A
DATE	DESCRIPTION	REV.

# Mouser Electronics

Authorized Distributor

Click to View Pricing, Inventory, Delivery & Lifecycle Information:

[Keystone Electronics:](#)

[2478](#)