

MDSM-4 15.3mm Surface Mount Reed Switch



Description

The MDSM-4 surface mount reed switch is a sub-miniature, normally open switch with a 15.24mm long x 2.28mm diameter (0.600" x 0.090") glass envelope, capable of switching 200Vdc at 10W.

This reed switch is a surface mount version of MDCG-4. It has high insulation resistance of 10^{10} ohms minimum and a contact resistance of less than 100 milliohms.

Features

- Surface mount, normally open switch
- Low, stable contact resistance
- Capable of switching 200Vdc or 0.5A at up to 10W
- Available sensitivity 12-38 AT

Agency Approvals

Agency	Agency File Number	Ampere-Turns Range
	E47258 E471070	12-38 AT
	DEMKO 14 ATEX 1393U	12-38 AT

Benefits

- Hermetically sealed switch contacts are not affected by and have no effect on their external environment
- Zero operating power required for contact closure
- Excellent for switching micro-controller logic level loads

Dimensions

Dimensions in mm (inch)

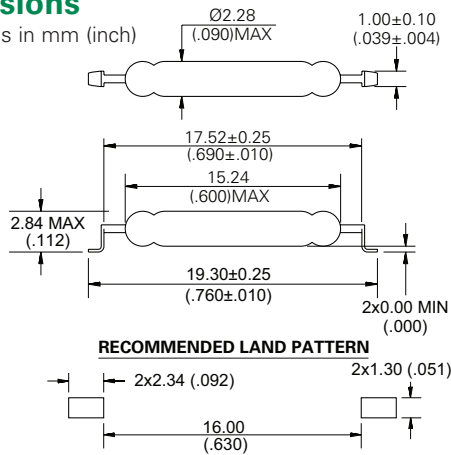

Note: Land pattern is Littelfuse recommendation only. User is responsible for proper PCB design.

Applications

- Position Sensing
- Level sensing
- Industrial Controls
- Security
- Limit Switching
- Office Equipment

Switch Type

Contact Form	A (SPST-NO)
Materials	Body: Glass Leads: Tin-plated Ni-Fe wire

Note: SPST-NO = Single-pole, single-throw, normally open

Electrical Ratings

Contact Rating ¹		W/VA - max.	10
Voltage ³	Switching ²	Vdc - max.	200
	Breakdown ⁴	Vac - max.	140
		Vdc - min.	250
Current ³	Switching ²	Adc - max.	0.50
	Carry	Aac - max.	0.35
		Adc - max.	1.20
Resistance	Contact, Initial Insulation	Ω - max.	0.100
		Ω - min.	10^{10}
Capacitance	Contact	pF - typ.	0.2
Temperature	Operating Storage ⁵	$^{\circ}\text{C}$	-40 to +125
		$^{\circ}\text{C}$	-65 to +125

Notes:

1. Contact rating - Product of the switching voltage and current should never exceed the wattage rating. Contact Littelfuse for additional load/life information.
2. When switching inductive and/or capacitive loads, the effects of transient voltages and/or currents should be considered. Refer to Application Notes AN108A and AN107 for details.
3. Electrical Load Life Expectancy - Contact Littelfuse with voltage, current values along with type of load.
4. Breakdown Voltage - per MIL-STD-202, Method 301.
5. Storage Temperature - Long time exposure at elevated temperature may degrade solderability of the leads.

MDSM-4 15.3mm Surface Mount Reed Switch

Product Characteristics

Operating Characteristics		
Operate Time ¹		0.6ms - max.
Release Time ¹		0.2ms - max.
Shock ²	11ms 1/2 sine wave	100G - max.
Vibration ²	50-2000 Hertz	30G - max.
Resonant Frequency		3.9kHz - typ.
Magnetic Characteristics		
Pull-In Range ³	Ampere Turns	12-38
Rating Sensitivity ⁴	Ampere Turns	20
Test Coil		L4989

Notes:

- Operate (including bounce)/Release Time - per EIA/NARM RS-421-A, diode suppressed coil (Coil II).
- Shock and Vibration - per EIA/NARM RS-421-A and MIL-STD-202.
- Pull-In Range - Contact Littelfuse for narrower AT ranges available. These AT values are the before modification AT of the MDCG-4.
- Rating Sensitivity - The value at which contact ratings and operating characteristics are determined. Derating may be required below this value.

Drop-Out vs. Pull-In Chart

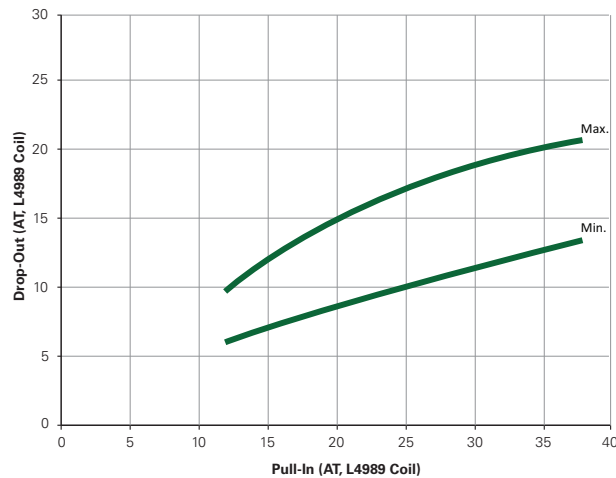

Note: Chart represents the range of Drop-Out, min to max, for a given Pull-In value of the MDCG-4 prior to modification into the MDSM-4.

Part Numbering System

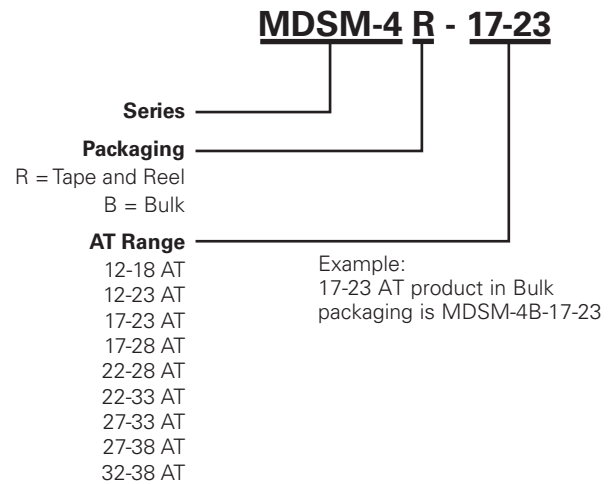

Note: These AT values are the before-modification values of the bare reed switch.

Additional Information



Datasheet



Resources



Samples

Packaging

Packaging Option	Packaging Specification	Quantity	Quantity and Packaging Code	Taping Width
Tape and Reel	EIA-RS-481-1	3000	R	32mm
Bulk	N/A	200	B	N/A

MDSM-4 15.3mm Surface Mount Reed Switch

TAPE DIMENSIONS mm (inch)

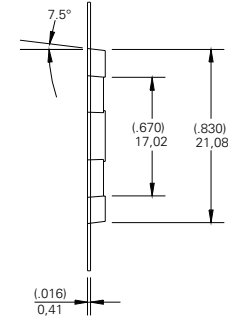
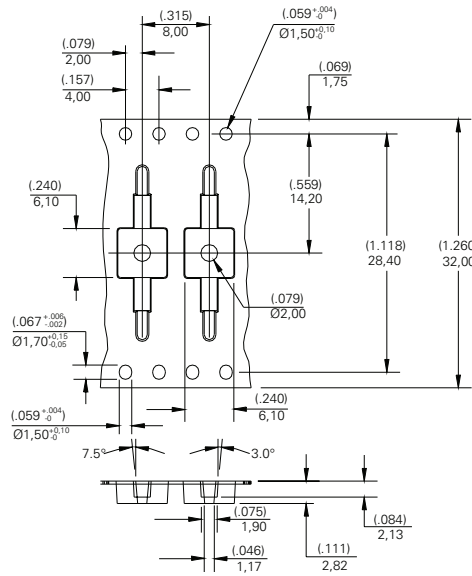

1. ALL TAPE & SPROCKET HOLE DIMENSIONS ARE PER EIA-481 UNLESS NOTED
2. ALL POCKET DIMENSIONS ARE $\pm(.004)$ 0,10mm
3. ALL DIMENSIONS ARE TO INSIDE OF POCKET

REEL DIMENSIONS mm (inch)

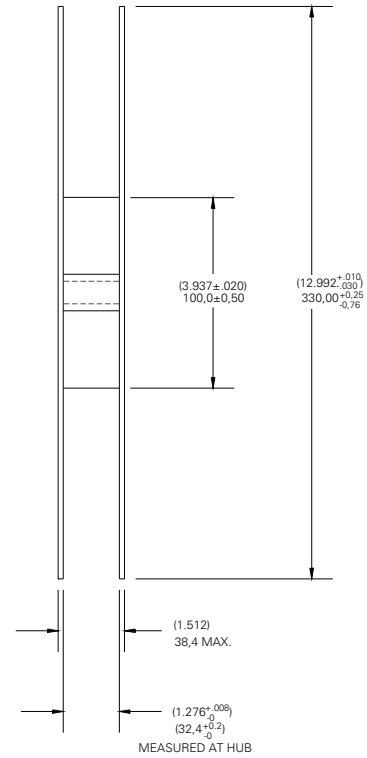
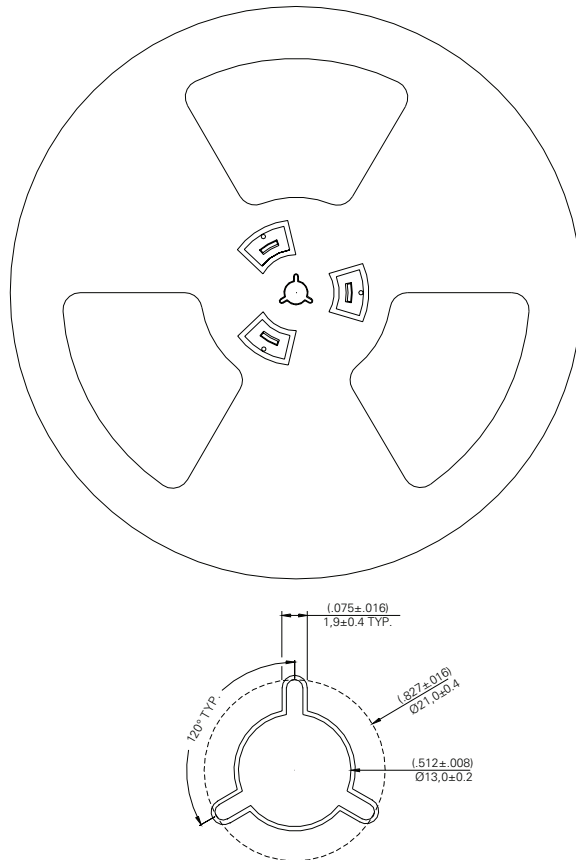

Mouser Electronics

Authorized Distributor

Click to View Pricing, Inventory, Delivery & Lifecycle Information:

Littelfuse:

[MDSM-4B 12-23](#) [MDSM-4B 17-38](#) [MDSM-4B 22-28](#) [MDSM-4B 17-28](#) [MDSM-4B 27-38](#) [MDSM-4B 32-38](#) [MDSM-4B 22-33](#) [MDSM-4B 12-28](#) [MDSM-4B 12-38](#) [MDSM-4R 17-28](#) [MDSM-4R 22-33](#) [MDSM-4R 27-33](#) [MDSM-4R 22-28](#) [MDSM-4R 12-28](#) [MDSM-4R 12-23](#) [MDSM-4R 12-38](#) [MDSM-4R 22-38](#) [MDSM-4R 17-38](#) [MDSM-4R 27-38](#) [MDSM-4R 17-23](#) [MDSM-4B 12-18](#) [MDSM-4B 17-23](#) [MDSM-4B 22-38](#) [MDSM-4B 27-33](#) [MDSM-4R 32-38](#) [MDSM-4R 12-18](#) [MDSM-4R-12-18](#) [MDSM-4B-22-38](#) [MDSM-4R-12-28](#) [MDSM-4B-12-38](#) [MDSM-4B-32-38](#) [MDSM-4B-22-28](#) [MDSM-4R-32-38](#) [MDSM-4R-17-28](#) [MDSM-4B-17-23](#) [MDSM-4R-22-33](#) [MDSM-4B-12-28](#) [MDSM-4R-17-38](#) [MDSM-4R-12-38](#) [MDSM-4B-27-33](#) [MDSM-4R-17-23](#) [MDSM-4R-22-28](#) [MDSM-4R-12-23](#) [MDSM-4R-22-38](#) [MDSM-4B-27-38](#) [MDSM-4B-12-18](#) [MDSM-4B-22-33](#) [MDSM-4B-17-38](#) [MDSM-4B-17-28](#) [MDSM-4R-27-33](#) [MDSM-4R-27-38](#) [MDSM-4B-12-23](#) [MDSM-4R-7-13](#)