

# Long Distance Reflective Switch

OPB732, OPB732WZ



## Features:

- PC board mounting (OPB732)
- 24" (610 mm) 26 AWG wired with mounting tabs (OPB732WZ)
- Non-contact infrared switch
- Up to 1" or more reflective distance depending on circuitry

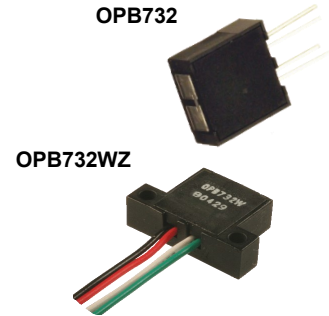

## Description:

**OPB732** uses an Infrared LED and Phototransistor in a reflective switch configuration. The assembly is offered with either PCBoard through hole pins (**OPB732**) or 24" (610 mm), 26 AWG wires (**OPB732WZ**), and uses an opaque housing to reduce the sensor's ambient light sensitivity. The emitter and sensor are protected by a clear window, providing a device that can operate in a dusty environment. The phototransistor can be configured as a Common Collector or Common Emitter device.

While an object is in the reflective path of the device, light from the LED will be reflected back to the housing irradiating the surface (base) of the phototransistor. When Infrared light strikes the phototransistor, the transistor becomes forward biased and is considered to be in the "ON" state, providing an  $I_{C(ON)}$  current proportional to the light striking the phototransistor. With the Infrared light from the LED not being reflected to the phototransistor, the phototransistor turns "OFF," minimizing the  $I_{C(ON)}$  current.

Custom electrical, wire and cabling and connectors are available. Contact your local representative or OPTEK for more information.

## Applications:

- Non-contact reflective object sensor
- Assembly line automation
- Machine automation
- Equipment security
- Door sensor
- Machine safety
- End of travel sensor

Ordering Information		
Part Number	LED Peak Wavelength	Lead Length / Spacing
OPB732	850 nm	0.150" / see diagram
OPB732WZ		24" / 26 AWG Wire



RoHS

General Note  
TT Electronics reserves the right to make changes in product specification without notice or liability. All information is subject to TT Electronics' own data and is considered accurate at time of going to print.

OPTEK Technology, Inc.  
1645 Wallace Drive, Carrollton, TX 75006 | Ph: +1 972 323 2200  
www.optekinc.com | www.ttelectronics.com

# Long Distance Reflective Switch

OPB732, OPB732WZ

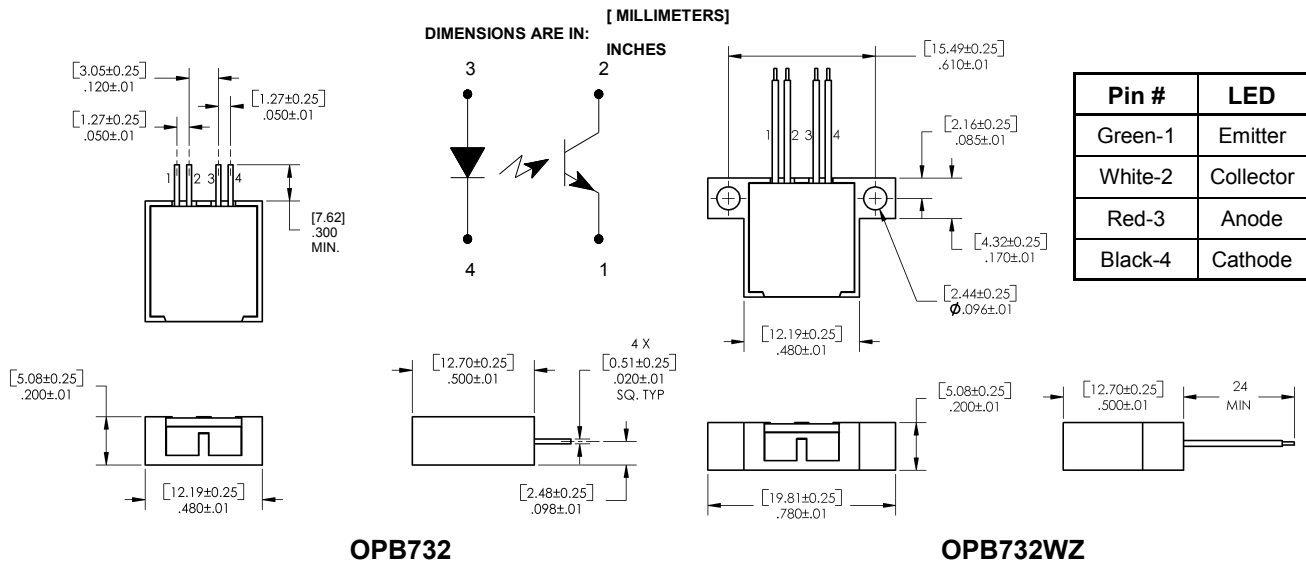

General Note  
 TT Electronics reserves the right to make changes in product specification without notice or liability. All information is subject to TT Electronics' own data and is considered accurate at time of going to print.

OPTEK Technology, Inc.  
 1645 Wallace Drive, Carrollton, TX 75006 | Ph: +1 972 323 2200  
[www.optekinc.com](http://www.optekinc.com) | [www.ttelectronics.com](http://www.ttelectronics.com)

# Long Distance Reflective Switch

OPB732, OPB732WZ



## Electrical Specifications

Absolute Maximum Ratings ( $T_A = 25^\circ\text{C}$ unless otherwise noted)						
Storage Temperature	-40° C to +100° C					
Operating Temperature	-40° C to +85° C					
Lead Soldering Temperature (1/16" (1.6mm) from case for 5 seconds with soldering iron) <sup>(2)</sup>	260° C					
LED						
Forward Current	50 mA					
Peak Forward current (2 $\mu\text{s}$ pulse width, 0.1% Duty Cycle)	1 A					
Reverse DC Voltage	3 V					
Power Dissipation	100 mW					
Output Photo Transistor						
Collector-Emitter Voltage	30 V					
Collector DC Current	50 mA					
Power Dissipation	100 mW					
Electrical Characteristics ( $T_A = 25^\circ\text{C}$ unless otherwise noted)						
SYMBOL	PARAMETER	MIN	TYP	MAX	UNITS	TEST CONDITIONS
Input LED (See OP265 for additional information, reference only)						
$V_F$	Forward Voltage	-	-	1.8	V	$I_F = 20\text{ mA}$
$I_R$	Reverse Current	-	-	100	$\mu\text{A}$	$V_R = 2\text{ V}$
Output Phototransistor (See OP505 for additional information, reference only)						
$V_{(BR)CEO}$	Collector-Emitter Breakdown Voltage	30	-	-	V	$I_C = 100\ \mu\text{A}$ , $E_E = 0\text{ mw/cm}^2$
$I_{CEO}$	Collector-Emitter Dark Current	-	-	100	nA	$V_{CE} = 10\text{ V}$ , $E_E = 0\text{ mw/cm}^2$
Coupled						
$V_{CE(SAT)}$	Collector-Emitter Saturation Voltage <sup>(4)</sup>	-	-	0.4	V	$I_C = 250\ \mu\text{A}$ , $I_F = 30\text{ mA}$ , (4)
$I_{C(ON)}$	On-State Collector Current <sup>(4)</sup>	0.25	-	-	mA	$V_{CE} = 1\text{ V}$ , $I_F = 30\text{ mA}$ , (4)
$I_{CX}$	Cross Talk	-	-	50	$\mu\text{A}$	$V_{CE} = 5\text{ V}$ , $I_F = 30\text{ mA}$ , No reflective surface

**Notes:**

- (1) All parameters tested using pulse technique.
- (2) RMA flux is recommended. Duration can be extended to 10 seconds maximum when flow soldering.
- (3) Methanol or isopropanol are recommended as cleaning agents. The plastic housing is soluble in chlorinated hydrocarbons and ketones.
- (4) Distance = 1" (from front of package to a 90% diffuse reflective white card)

General Note  
 TT Electronics reserves the right to make changes in product specification without notice or liability. All information is subject to TT Electronics' own data and is considered accurate at time of going to print.

OPTEK Technology, Inc.  
 1645 Wallace Drive, Carrollton, TX 75006  
 Ph: +1 972 323 2200  
[www.optekinc.com](http://www.optekinc.com) | [www.ttelectronics.com](http://www.ttelectronics.com)

# Long Distance Reflective Switch

OPB732, OPB732WZ



$I_{C(ON)}$  vs Distance ( $I_F=30mA$ )

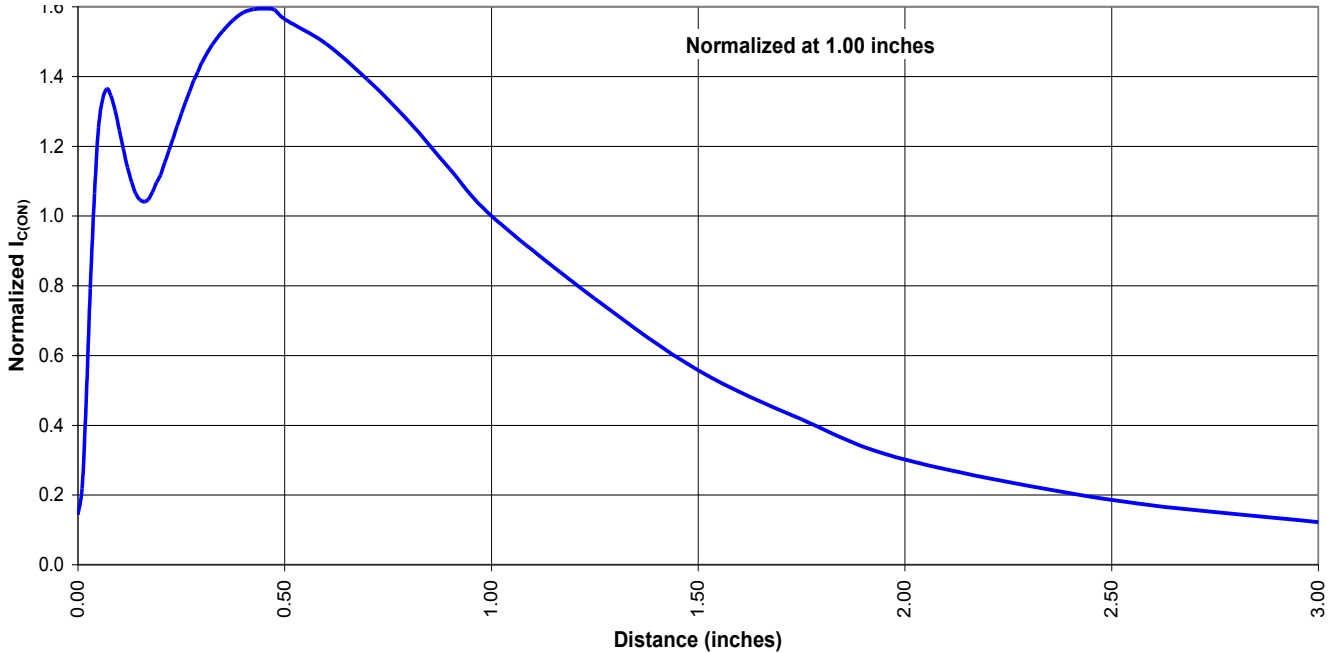

DC—Drive Circuit for LED & Phototransistor

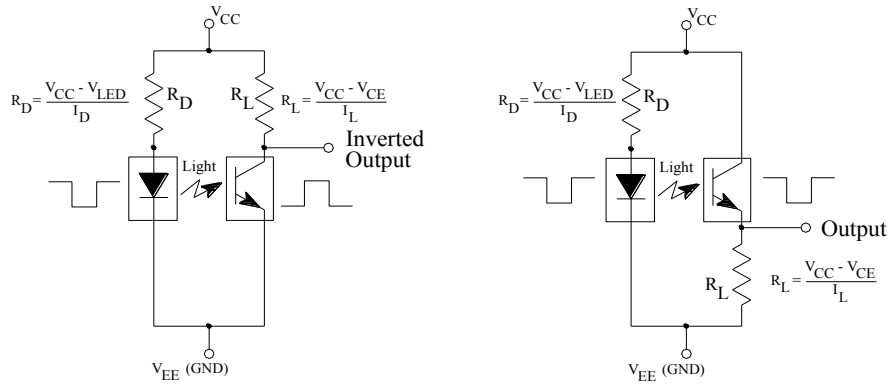

Pulsed—Drive Circuit for LED & Phototransistor

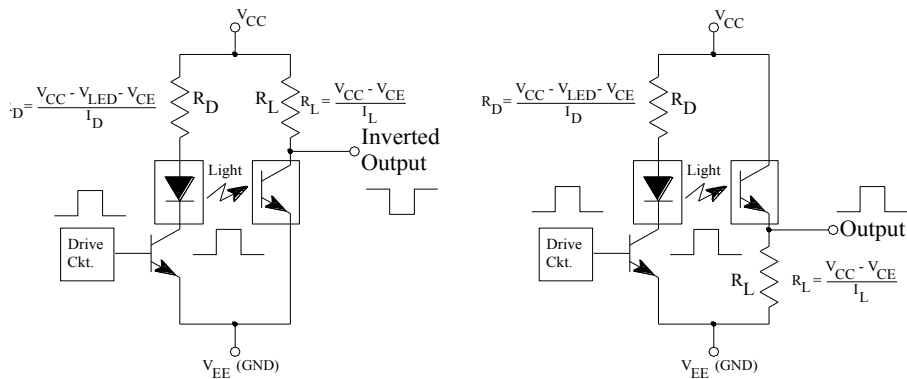

General Note  
TT Electronics reserves the right to make changes in product specification without notice or liability. All information is subject to TT Electronics' own data and is considered accurate at time of going to print.

OPTEK Technology, Inc.  
1645 Wallace Drive, Carrollton, TX 75006 | Ph: +1 972 323 2200  
www.optekinc.com | www.ttelectronics.com

# Mouser Electronics

Authorized Distributor

Click to View Pricing, Inventory, Delivery & Lifecycle Information:

[TT Electronics:](#)

[OPB732](#)