

## High-speed, High-precision positioning with 1, 2, or 4 axes

- Versatile functions and superb performance enable the construction of compact, high-performance machines.
- With its ultra-compact size of 31 × 90 mm (W × H), this highly space-efficient Position Control Unit (PCU) enables up to 4 axes of motor control.



## Features

- Two types to choose from: open collector output and line driver. Because both open collector output and line driver types feature 1-, 2-, and 4-axis models, the most appropriate model can be selected for the application at hand.
- Positioning START occurs within 2 ms (maximum speed) after receiving a command from the Programmable Controller. (Refer to the Operation Manual for conditions.)
- High-speed data transfer is possible using INTELLIGENT I/O WRITE (IOWR) and INTELLIGENT I/O READ (IORD) instructions.
- Fine control from low to high speed (500 kpps max.) is possible in 1-pps units.
- Positioning can be done from memory, by writing an operating pattern into the PCU memory in advance. Three position patterns – Terminating, Automatic, and Continuous – can be set with completion codes to respond to a wide range of operations. Positioning of up to 100 patterns (sequential data) per one axis can be possible.
- Positioning (direct operation) can be done by direct PLC ladder commands for position data, speed data, and acceleration data. This simplifies control in situations when the target position and speed cannot be decided until immediately before operation begins, or when the target position and speed change due to other circumstances. The target position and speed can also be changed during operation.
- Interrupt feeding moves the axis a specified amount, then stops it, in accordance with an interrupt input. High-speed (0.1 ms max.) processing of the interrupt input signal ensures high-precision interrupt positioning. This helps to maximize feeder precision.
- Easy-to-Use positioning can be possible with versatile functions such as Teaching, Override, Backlash compensation, Zones, Forced interrupt and Acceleration/Deceleration curve.

## System Configuration

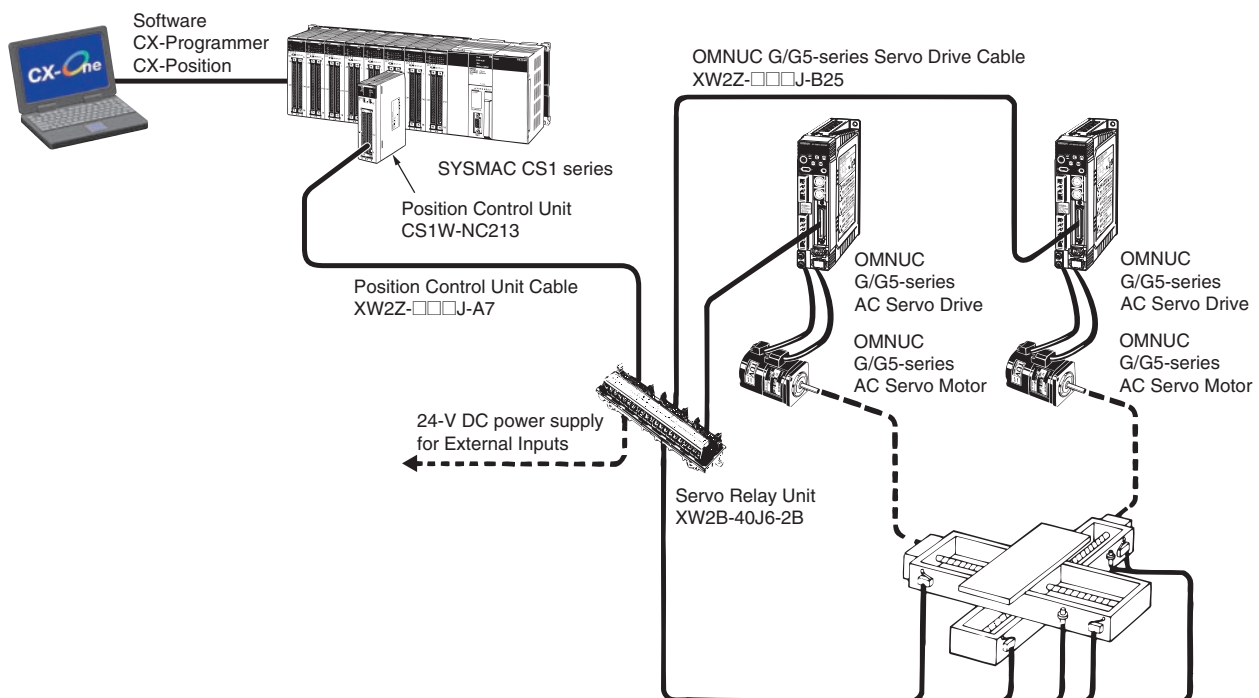

## Ordering Information

### International Standards

- The standards are abbreviated as follows: U: UL, U1: UL(Class I Division 2 Products for Hazardous Locations), C: CSA, UC: cULus, UC1: cULus (Class I Division 2 Products for Hazardous Locations), CU: cUL, N: NK, L: Lloyd, and CE: EC Directives.
- Contact your OMRON representative for further details and applicable conditions for these standards.

## Position Control Unit

Unit type	Name	Specifications		No. of unit numbers allocated	Current consumption (A)		Model	Standards
		Control method/Control output interface	Number of control axes		5 V system	26 V system		
CS1 Special I/O Units	<b>Position control unit</b> 	Open-loop control by pulse train output/ Open-collector output	1 axis	1	0.25	–	CS1W-NC113	U, C, N, L, CE
			2 axes		0.25	–	CS1W-NC213	
			4 axes	2	0.36	–	CS1W-NC413	
		Open-loop control by pulse train output/ Line-driver output	1 axis	1	0.25	–	CS1W-NC133	
			2 axes		0.25	–	CS1W-NC233	
			4 axes	2	0.36	–	CS1W-NC433	

## Software

Name	Specifications	Number of licenses	Model	Standards
<b>CX-One FA Integrated Tool Package Ver. 4</b>	<p>The CX-One is a comprehensive software package that integrates Support Software for OMRON PLCs and components. CX-One runs on the following OS. OS : Windows XP (Service Pack 3 or higher, 32-bit version) / Windows Vista (32-bit/64-bit version) / Windows 7 (32-bit/64-bit version) / Windows 8 (32-bit/64-bit version) / Windows 8.1 (32-bit/64-bit version) / Windows 10 (32-bit/64-bit version)</p> <p>CX-One Ver.4. □ includes CX-Position Ver.2. □. For details, refer to the CX-One catalog (Cat. No.R134).</p>	1 license * DVD	CXONE-AL01D-V4	–

\* Multi licenses (3, 10, 30, or 50 licenses) and DVD media without licenses are also available for the CX-One.

## Servo Relay Units/Cables

Name	Applicable units	Applicable drives	Number of control axes	Cable length	Model	Standards	
<b>Servo Relay Unit</b>	For CS1W-NC113/133 (No communication supported)	–	1 axis	–	XW2B-20J6-1B	–	
	For CS1W-NC213/233/413/433 (No communication supported)	–	2 axes	–	XW2B-40J6-2B	–	
	For CS1W-NC113/133/213/233/413/433 (Communication supported)	–	2 axes	–	XW2B-40J6-4A	–	
<b>Position Control Unit Cables for Servo Relay Unit</b>	Open-collector output	For CS1W-NC113	1 axis	0.5m	XW2Z-050J-A6	–	
				1m	XW2Z-100J-A6		
				0.5m	XW2Z-050J-A8		
		1m		XW2Z-100J-A8			
		For CS1W-NC213/413		2 axes	0.5m		XW2Z-050J-A7
					1m		XW2Z-100J-A7
	0.5m		XW2Z-050J-A9				
	1m	XW2Z-100J-A9					
	Line-driver output	For CS1W-NC133	1 axis		0.5m		XW2Z-050J-A10
					1m		XW2Z-100J-A10
				0.5m	XW2Z-050J-A12		
		1m		XW2Z-100J-A12			
For CS1W-NC233/413		2 axes		0.5m	XW2Z-050J-A11		
				1m	XW2Z-100J-A11		
	0.5m		XW2Z-050J-A13				
1m	XW2Z-100J-A13						

### Communications Cables for Serial Communications Boards/Units

Name	Specifications	Applicable Serial Communications Units/Boards	Applicable Servo Driver	Cable Length	Model
<b>Communications Cables for Serial Communications Boards/Units</b>	RS-422A Communications cable (Servo Relay Unit XW2B-40J6-4A required *)	CS1W-SCB41-V1	OMNUC W Series, SMARTSTEP A Series	1m	XW2Z-100J-C1
		CS1W-SCU31-V1		2m	XW2Z-200J-C1

\* Communication Supported.

**Accessories**

The Position Control Unit includes the 48-pin solder-type connectors (socket: Fujitsu FCN-361J048-AU, cover: Fujitsu FCN-360C048-D).

**Mountable Racks**

Model	CS1 System			CS1D System	
	CPU Rack	Expansion Backplane	Long-distance Expansion Racks	CPU Rack	Expansion Backplane
CS1W-NC113/133/213/233/413/433	Yes	Yes	Yes	Yes	Yes

**Specifications**

**Basic Specifications**

Item	Model		
	CS1W-NC113/133	CS1W-NC213/233	CS1W-NC413/433
Power supply voltage	5 VDC (for the PCU itself)		
	24 VDC (external power supply)		
	5 VDC (external power supply; line driver output only)		
Allowable power supply voltage range	4.75 to 5.25 VDC (for the PCU itself)		
	21.6 to 26.4 VDC (external power supply)		
	4.75 to 5.25 VDC (external power supply; line driver output only)		
Internal current consumption	250 mA max. at 5 VDC	250 mA max. at 5 VDC	360 mA max. at 5 VDC
Current consumption of external power supply	NC113: 30 mA max. at 24 VDC NC133: 10 mA max. at 24 VDC NC133: 60 mA max. at 5 VDC	NC213: 50 mA max. at 24 VDC NC233: 20 mA max. at 24 VDC NC233: 120 mA max. at 5 VDC	NC413: 90 mA max. at 24 VDC NC433: 30 mA max. at 24 VDC NC433: 220 mA max. at 5 VDC
External dimensions	130 (H) × 35 (W) × 101 (D) (all models)		
Weight	250 g max.	250 g max.	300 g max.
Safety standards	UL, CSA, EC (EMC Directive)		

**Note:** Specifications not listed above conform to CS Series general specifications.

**Performance Specifications**

Item	Model		
	CS1W-NC113/133	CS1W-NC213/233	CS1W-NC413/433
Applicable PLC models	CS-series PLCs		
Unit type	CS1 Special I/O Unit		
I/O requirements	Words	5 words	10 words
	Slots	1 slot	
Controlled driver	Pulse-train input-type Servo Drive or stepping motor driver NC113/213/413 models have open collector output. NC133/233/433 models have line driver output.		
Control	Control system	Open-loop control by pulse train output	
	Number of control axes	1 axis	2 axes
Control unit	Pulse		
Positioning operations	Two types: memory operation and direct operation		
	Independent	1 axis	2 independent axes
	Linear interpolation	None	2 axes max.
	Speed control	1 axis	2 independent axes
	Interrupt feeding	1 axis	2 independent axes
Positions	Range	-1,073,741,823 to 1,073,741,823 pulses (See note.)	
	Data items	100/axis	
Speeds	Range	1 pps to 500 Kpps	
	Data items	100/axis	
Acceleration and deceleration times	Range	0 to 250 s, until maximum speed is reached.	
	Data items	9/axis for acceleration and deceleration each	

Item	Model		
	CS1W-NC113/133	CS1W-NC213/233	CS1W-NC413/433
Functions and settings	Origin search	Origin proximity input signal: selectable (absent, N.O. or N.C. contact). Origin input signal: selectable (N.O. or N.C. contact) Origin compensation: -1,073,741,823 to 1,073,741,823 pulses Origin search speed: High-speed or proximity-speed can be set. Origin detection method: May be set to stop upon origin input signal after proximity input signal has turned ON, to stop upon origin input signal after proximity input signal has turned OFF, to stop upon origin input signal without using proximity input signal, or to stop upon origin input signal after limit input signal has turned OFF. N.O. = Normally open N.C. = Normally closed	
	Jogging	Jogging can be executed at a specified speed.	
	Dwell times	19/axis can be set from 0 to 9.99 s (unit: 0.01 s).	
	Acceleration/ deceleration curves	Trapezoidal or S-curve (Can be set separately for each axis.)	
	Zones	Zone Flag turns ON when present position is within a specified zone. Three zones can be set for each axis.	
	Software limits	Can be set within a range of -1,073,741,823 to 1,073,741,823 pulses.	
	Backlash compensation	0 to 9,999 pulses. Compensation speed can also be set.	
Functions and settings	Teaching	With a command from the PLC, the present position can be taken as the position data.	
	Deceleration stop	The STOP command causes positioning to decelerate to a stop according to the specified deceleration time.	
	Emergency stop	Pulse outputs are stopped by an external emergency stop command.	
	Present position preset	The PRESENT POSITION PRESET command can be used to change the present position to a specified value.	
	Override	When the override enabling command is executed during positioning, the target speed is changed by applying the override coefficient. Possible to set to a value from 1 to 999% (by an increment of 1%)	
	Data saving	1) Saving to flash memory. (Can be written 100,000 times.) 2) Reading from PLC area by data reading instruction. 3) Reading by Support Tool and saving to personal computer hard disk or floppy disk.	
External I/O	Inputs	Prepare the following inputs for each axis: CW and CCW limit input signals, origin proximity input signal, origin input signal, emergency stop input signal, positioning completed signal, interrupt input signal	
	Outputs	Prepare the following outputs for each axis: Pulse outputs CW/CCW pulses, pulse outputs and direction outputs can be switched. Either error counter reset or origin-adjustment command outputs can be selected depending on the mode.	
Pulse output distribution period	1-axis operation: 4 ms Linear interpolation: 8 ms		
Response time	Refer to Operation Manual <i>Appendix A Performance Characteristics</i> .		
Self-diagnostic function	Flash memory check, memory loss check, CPU bus check		
Error detection function	Overtravel, CPU error, software limit over, emergency stop		

- Note: 1.** The additional functions supported by Unit version 2.0 can be used only when the PCU is installed with a CS1-H CPU Unit (either CPU Unit Ver. 2.0 or Pre-Ver. 2.0 CPU Unit). These functions cannot be used if the PCU is installed with a CS1 CPU Unit (with -V1 suffix). For details on Unit versions, refer to *Unit Versions of CS-series Position Control Units* on Operation Manual page vi.
- 2.** When performing linear interpolation, the distances that can be moved will vary.

## External Interface

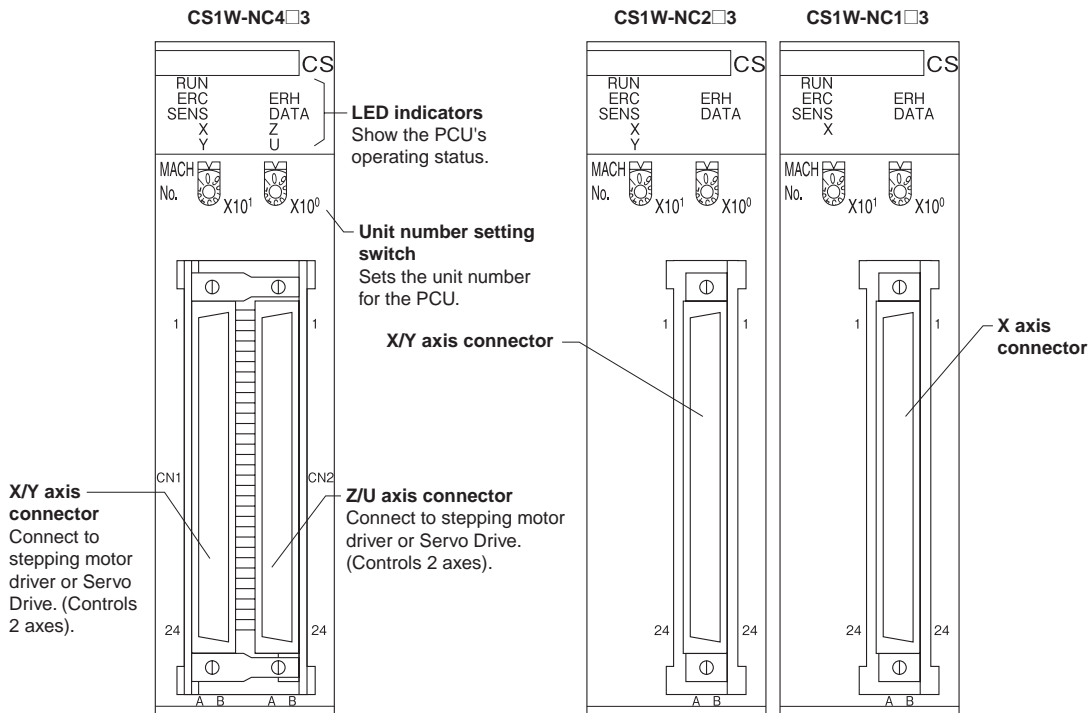

## LED Indicators

Name	Color	Status	Explanation
RUN	Green	Lit	Lit during normal operation.
		Not lit	Hardware error, or PLC notified of PCU error.
ERC	Red	Lit	An error has occurred.
		Not lit	No error has occurred.
ERH	Red	Lit	An error has occurred IN the CPU Unit.
		Not lit	No error has occurred at the CPU Unit.
SENS	Yellow	Lit	Either a CW/CCW limit signal or an emergency stop input signal is being input. At this time the LED indicator for the relevant axis (X to U) will flash.
		Flashing	Either a parameter loss, a data loss, or an operating data area designation error has occurred.
		Not lit	None of the above has occurred.
DATA	Yellow	Lit	Data is incorrect (e.g., the parameters or positions transferred are out of the permissible range). At this time the LED indicator for the relevant axis (X to U) will flash.
		Flashing	The check of all data (parameters, positions, etc.) following power up shows that data is lost or corrupted.
		Not lit	None of the above has occurred.
X	Orange	Lit	Pulses are being output to the X axis (either forward or reverse).
		Flashing	An error has occurred, such as incorrect cable type for the X axis or faulty data.
		Not lit	None of the above has occurred.
Y	Orange	Lit	Pulses are being output to the Y axis (either forward or reverse).
		Flashing	An error has occurred, such as incorrect cable type for the Y axis or faulty data.
		Not lit	None of the above has occurred.
Z	Orange	Lit	Pulses are being output to the Z axis (either forward or reverse).
		Flashing	An error has occurred, such as incorrect cable type for the Z axis or faulty data.
		Not lit	None of the above has occurred.
U	Orange	Lit	Pulses are being output to the U axis (either forward or reverse).
		Flashing	An error has occurred, such as incorrect cable type for the U axis or faulty data.
		Not lit	None of the above has occurred.

- Note: 1.** For the CS1W-NC113/NC133, this applies only to the X axis; for the CS1W-NC213/NC233, it applies only to the X and Y axes.
- 2.** When not all of the axes are used for the CS1W-NC213/NC233/ NC413/NC433, either connect the CW/CCW limit inputs for the unused axes to the input power supply and turn them ON or set the contact logic to N.O. Connect the emergency stop to the input common and turn it ON. If it is not connected, the ERC indicator will light. Operation will be normal, however, for all axes that are used.

## Functions Supported by Each Unit Version of Position Control Unit

Unit Version		Pre-Ver. 2.0	Ver. 2.0	Ver. 2.1	Ver. 2.2	Ver. 2.3
Internal system software version		1.0	2.0	2.1	2.2	2.3
CS-series Position Control Units		CS1W-NC113/133/213/233/413/433				
Functions	Changing the acceleration for a multiple start during relative movement or absolute movement in direct operation	Not supported	Supported	Supported	Supported	Supported
	Changing acceleration/ deceleration time during jog operation	Not supported	Supported	Supported	Supported	Supported
	Setting acceleration/ deceleration time for axis parameters until the target speed is reached	Not supported	Supported	Supported	Supported	Supported
	Easy backup function	Not supported	Supported	Supported	Supported	Supported
	Setting number of unused axes	Not supported	Not supported	Supported	Supported	Supported
	Setting CW/CCW pulse output direction	Not supported	Not supported	Not supported	Supported	Supported
	Setting origin search pattern	Not supported	Not supported	Not supported	Supported	Supported
	Position data setting when origin signal stops	Not supported	Not supported	Not supported	Supported	Supported
	Setting jog operation	Not supported	Not supported	Not supported	Not supported	Supported
	Setting deviation counter reset output signal	Not supported	Not supported	Not supported	Not supported	Supported
Checking parameters and data at startup	Not supported	Not supported	Not supported	Not supported	Supported	
Support Software	CX-Position Ver. 1.0 or later	CX-Position Ver. 1.0 (See note 2.) CX-Position Ver. 2.0 or later	CX-Position Ver. 1.0 (See note 2.) CX-Position Ver. 2.0 or later	CX-Position Ver. 1.0 (See note 2.) CX-Position Ver. 2.0 or later	CX-Position Ver. 1.0 (See note 2.) CX-Position Ver. 2.0 (See note 2.) CX-Position Ver. 2.1 or later	CX-Position Ver. 1.0 (See note 2.) CX-Position Ver. 2.0 (See note 2.) CX-Position Ver. 2.1 (See note 2.) CX-Position Ver. 2.2 or later

- Note: 1.** The Position Control Unit must be installed with CS1-H CPU Unit to use the above functions supported for Position Control Unit Ver. 2.0. These functions cannot be used if the Position Control Unit is installed with a CS1 CPU Unit (with -V1 suffix).
- 2.** With CX-Position Ver. 1.0, new functions added to Position Control Units Ver. 2.0 or higher cannot be used.
- 3.** Please refer to the Operation Manual Page vii for the Unit Version.

# Connecting Connectors Using Servo Relay Units

Wiring requires the dedicated cables.  
 Position Control Unit Cables, Servo Relay Unit, Servo Drive Cable are sold separately.

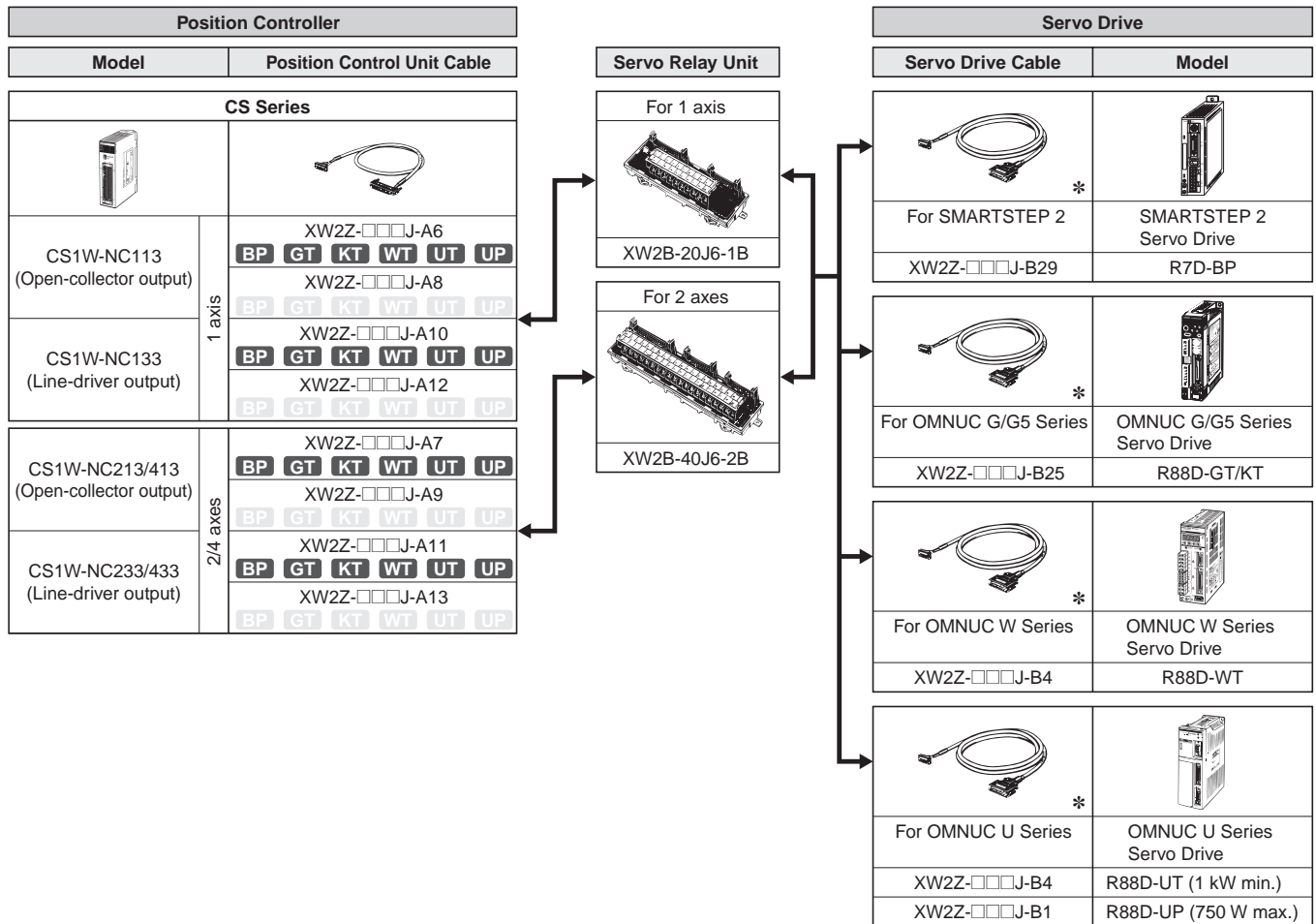

The following icons represents applicable servo drives.

- BP** : SMARTSTEP2
- GT** : OMNUC G Series
- KT** : OMNUC G5 Series
- WT** : OMNUC W Series
- UT** : OMNUC U Series (1 kW min.)
- UP** : OMNUC U Series (750 W max.)

\* Two Servo Drive Cables are required if 2-axis control is performed using one Position Control Unit.

Using Servo Relay Unit w/communications function

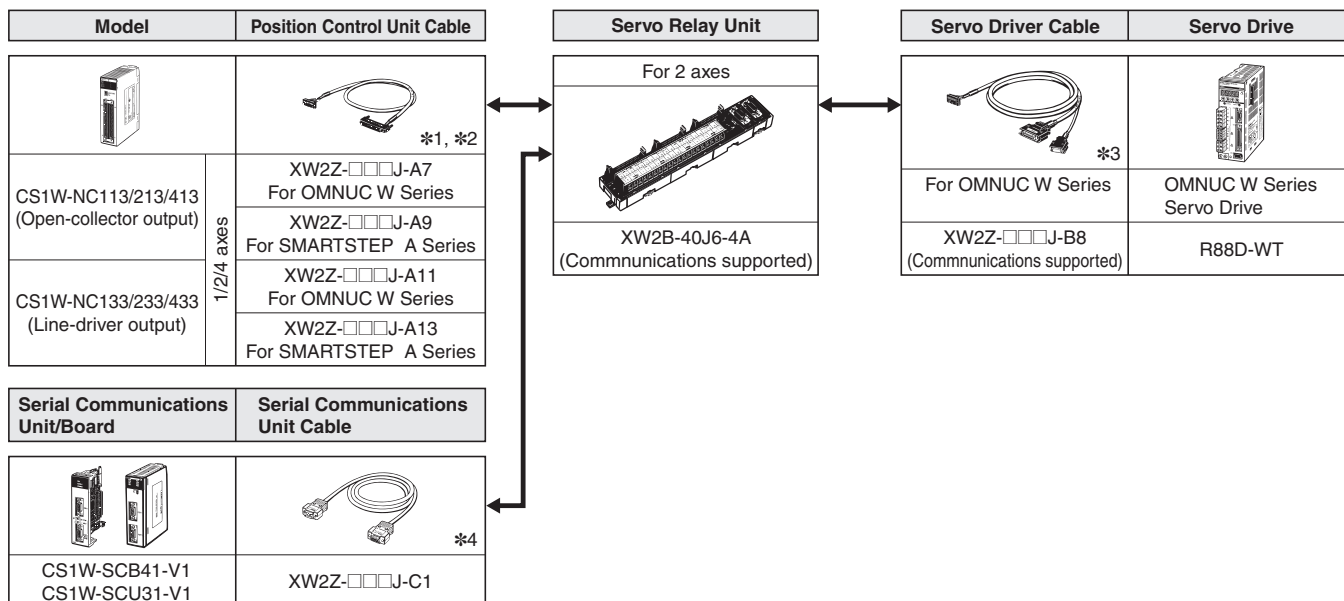

- \*1. When using for one-axis control, do not connect signal inputs to the Y-axis connector of XW2B-40J6-4A.
- \*2. When using two-axes control, you cannot mix W Series with SMARTSTEP A Series as Servo Drives.
- \*3. When using in combination with the CS1W-NC213/NC233 (2-axis control), 2 Servo Driver Connecting Cables are required. When using in combination with the CS1W-NC413/NC433 (4-axis control), 4 Servo Driver Connecting Cables are required.
- \*4. When using for two or four-axes control, connect between communications connectors of XW2B-40J6-4A with this cable.



Dimensions

(Unit: mm)

CS1W-NC113/213/413

CS1W-NC133/233/433

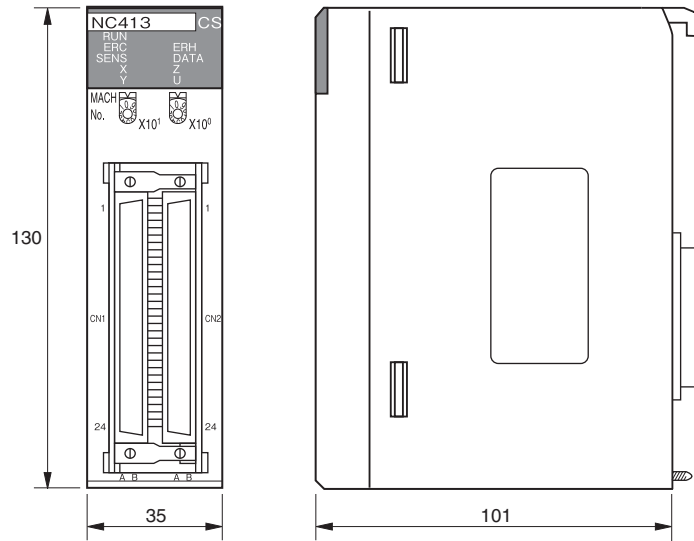

Note: The above diagram is for the CS1W-NC413.

Mounted Dimensions

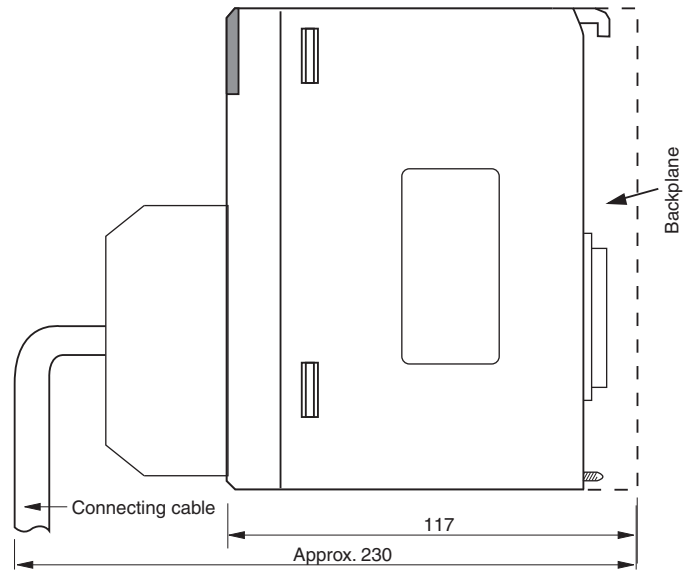

Related Manuals

Manual number		Model	Name	Contents
English	Japanese			
W376	SBCE-311	CS1W-NC113/133/213/233/413/433	Position Control Units Operation Manual	Provides information on operating and installing Position Control Units, including details, basic settings, memory operation, direct operation from CPU and other functions.
W433	SBCE-324	CXONE-AL□□D-V□	CX-Position Operation Manual	Provides an overview of CX-Position, its functions, and the system configuration, installation, and troubleshooting.

## Terms and Conditions Agreement

### Read and understand this catalog.

Please read and understand this catalog before purchasing the products. Please consult your OMRON representative if you have any questions or comments.

### Warranties.

(a) Exclusive Warranty. Omron's exclusive warranty is that the Products will be free from defects in materials and workmanship for a period of twelve months from the date of sale by Omron (or such other period expressed in writing by Omron). Omron disclaims all other warranties, express or implied.

(b) Limitations. OMRON MAKES NO WARRANTY OR REPRESENTATION, EXPRESS OR IMPLIED, ABOUT NON-INFRINGEMENT, MERCHANTABILITY OR FITNESS FOR A PARTICULAR PURPOSE OF THE PRODUCTS. BUYER ACKNOWLEDGES THAT IT ALONE HAS DETERMINED THAT THE PRODUCTS WILL SUITABLY MEET THE REQUIREMENTS OF THEIR INTENDED USE.

Omron further disclaims all warranties and responsibility of any type for claims or expenses based on infringement by the Products or otherwise of any intellectual property right. (c) Buyer Remedy. Omron's sole obligation hereunder shall be, at Omron's election, to (i) replace (in the form originally shipped with Buyer responsible for labor charges for removal or replacement thereof) the non-complying Product, (ii) repair the non-complying Product, or (iii) repay or credit Buyer an amount equal to the purchase price of the non-complying Product; provided that in no event shall Omron be responsible for warranty, repair, indemnity or any other claims or expenses regarding the Products unless Omron's analysis confirms that the Products were properly handled, stored, installed and maintained and not subject to contamination, abuse, misuse or inappropriate modification. Return of any Products by Buyer must be approved in writing by Omron before shipment. Omron Companies shall not be liable for the suitability or unsuitability or the results from the use of Products in combination with any electrical or electronic components, circuits, system assemblies or any other materials or substances or environments. Any advice, recommendations or information given orally or in writing, are not to be construed as an amendment or addition to the above warranty.

See <http://www.omron.com/global/> or contact your Omron representative for published information.

### Limitation on Liability; Etc.

OMRON COMPANIES SHALL NOT BE LIABLE FOR SPECIAL, INDIRECT, INCIDENTAL, OR CONSEQUENTIAL DAMAGES, LOSS OF PROFITS OR PRODUCTION OR COMMERCIAL LOSS IN ANY WAY CONNECTED WITH THE PRODUCTS, WHETHER SUCH CLAIM IS BASED IN CONTRACT, WARRANTY, NEGLIGENCE OR STRICT LIABILITY.

Further, in no event shall liability of Omron Companies exceed the individual price of the Product on which liability is asserted.

### Suitability of Use.

Omron Companies shall not be responsible for conformity with any standards, codes or regulations which apply to the combination of the Product in the Buyer's application or use of the Product. At Buyer's request, Omron will provide applicable third party certification documents identifying ratings and limitations of use which apply to the Product. This information by itself is not sufficient for a complete determination of the suitability of the Product in combination with the end product, machine, system, or other application or use. Buyer shall be solely responsible for determining appropriateness of the particular Product with respect to Buyer's application, product or system. Buyer shall take application responsibility in all cases.

NEVER USE THE PRODUCT FOR AN APPLICATION INVOLVING SERIOUS RISK TO LIFE OR PROPERTY OR IN LARGE QUANTITIES WITHOUT ENSURING THAT THE SYSTEM AS A WHOLE HAS BEEN DESIGNED TO ADDRESS THE RISKS, AND THAT THE OMRON PRODUCT(S) IS PROPERLY RATED AND INSTALLED FOR THE INTENDED USE WITHIN THE OVERALL EQUIPMENT OR SYSTEM.

### Programmable Products.

Omron Companies shall not be responsible for the user's programming of a programmable Product, or any consequence thereof.

### Performance Data.

Data presented in Omron Company websites, catalogs and other materials is provided as a guide for the user in determining suitability and does not constitute a warranty. It may represent the result of Omron's test conditions, and the user must correlate it to actual application requirements. Actual performance is subject to the Omron's Warranty and Limitations of Liability.

### Change in Specifications.

Product specifications and accessories may be changed at any time based on improvements and other reasons. It is our practice to change part numbers when published ratings or features are changed, or when significant construction changes are made. However, some specifications of the Product may be changed without any notice. When in doubt, special part numbers may be assigned to fix or establish key specifications for your application. Please consult with your Omron's representative at any time to confirm actual specifications of purchased Product.

### Errors and Omissions.

Information presented by Omron Companies has been checked and is believed to be accurate; however, no responsibility is assumed for clerical, typographical or proofreading errors or omissions.

# Mouser Electronics

Authorized Distributor

Click to View Pricing, Inventory, Delivery & Lifecycle Information:

Omron:

[CS1W-NC413](#) [CS1W-NC113](#) [CS1W-NC233](#) [CS1W-NC213](#) [CS1W-NC433](#) [XW2Z-200J-C1](#) [CS1W-NC133](#)