

PRODUCT DATA DRAWING

REVISION HISTORY			
REV	DESCRIPTION	DATE	APPROVED
-	NRN 34833	07/08	STW
A	DCN 41517	07/15	STW

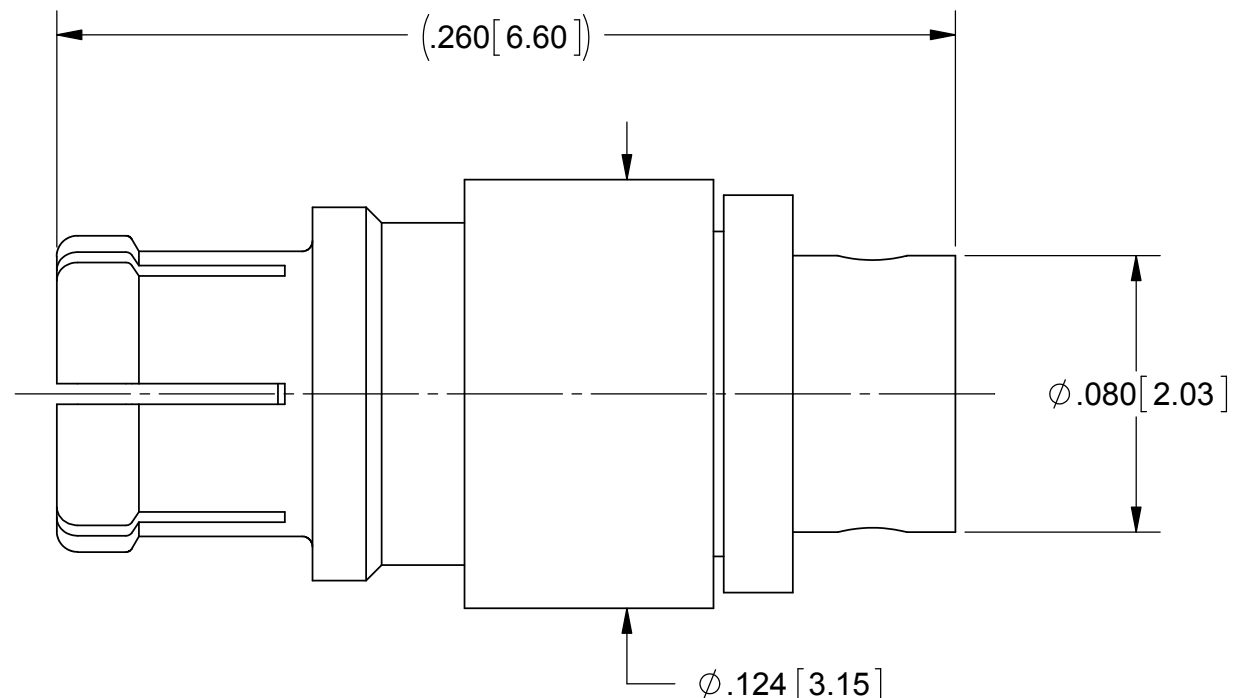
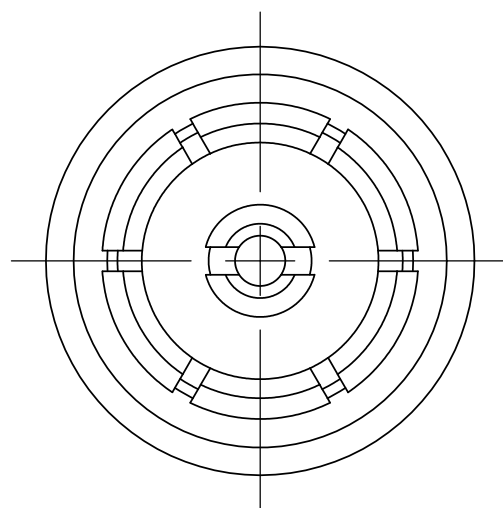
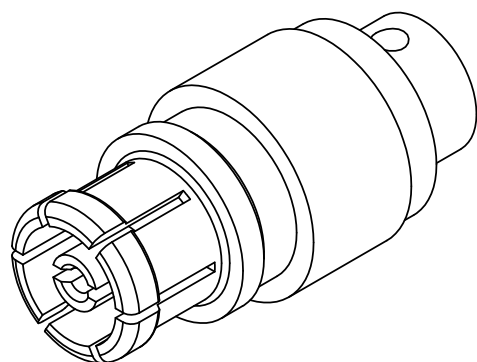

MATERIAL:

BODY & CONTACT: BERYLLIUM COPPER
 FERRULE: BRASS
 INSULATOR: PTFE

FINISH:

BODY, CONTACT & FERRULE: GOLD OVER NICKEL

PERFORMANCE:

IMPEDANCE: 50 OHMS
 FREQ. RANGE: DC TO 40.0 GHZ.
 VSWR: 1.15:1 DC TO 26.5 GHZ.
 1.25:1 DC TO 40.0 GHZ.

MATERIAL: SEE NOTES	DIMENSIONS ARE IN INCHES TOLERANCES: FRACTIONAL: ±1/64 ANGULAR: X° ±1'0" X°X' ±15'	UNLESS OTHERWISE SPECIFIED 1) ALL DIMENSIONS ARE IN INCHES (MILLIMETERS) 2) ALL DIMENSIONS ARE AFTER PLATING. 3) BREAK CORNERS & EDGES .005 R. MAX. 4) CHAM. 1ST & LAST THREADS. 5) SURFACE ROUGHNESS 63-MIL-STD-10. 6) DIA.'S ON COMMON CENTERS TO BE CONCENTRIC WITHIN .005 T.I.R. 7) REMOVE ALL BURRS	 2400 Centrepark West Drive, Suite 100 West Palm Beach, FL 33409 TITLE: SMPM STRAIGHT FEMALE FOR Ø.047 CABLE
FINISH: SEE NOTES	DECIMAL: X ±.030 .XX ±.010 .XXX ±.005	INTERPRET DIMENSIONS AND TOLERANCES PER ASME Y14.5M - 1994	
SURFACE AREA: N/A	THIRD ANGLE PROJECTION	DRAWN: DAL 07/02/08	SIZE CAGE CODE DWG. NO. B 95077 3221-40007
PROPRIETARY THE INFORMATION CONTAINED IN THIS DRAWING IS THE SOLE PROPERTY OF SV MICROWAVE, INC. ANY REPRODUCTION IN PART OR AS A WHOLE WITHOUT THE WRITTEN PERMISSION OF SV MICROWAVE, INC IS PROHIBITED.		CHECKED: STW 07/02/08	SCALE: 18:1
		APPROVED: STW 07/02/08	SHEET 1 OF 1

Mouser Electronics

Authorized Distributor

Click to View Pricing, Inventory, Delivery & Lifecycle Information:

[Amphenol:](#)

[3221-40007](#)