

## Dual Full Bridge Motor Driver

### FEATURES AND BENEFITS

- Low  $R_{DS(on)}$  outputs
- Drives two DC motors or single stepper motor
- Low power standby (Sleep) mode with zero current drain
- Thermal shutdown protection
- Parallel operation option for 1.8 A, single DC motor
- Overcurrent protection:
  - Output to supply short
  - Output to GND short
  - Output load short

### PACKAGES:

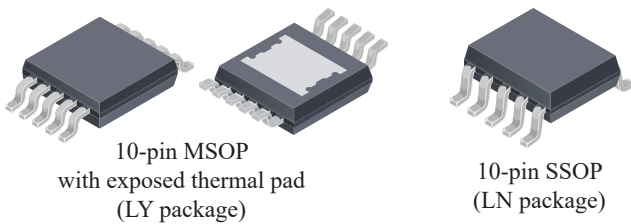

Not to scale

### DESCRIPTION

The A3909 is a dual full bridge motor driver, designed for 12 V medium power applications. The outputs are rated for operation through a power supply range of 4 to 18 V, and capable of up to 1 A per phase.

Paralleling the outputs is possible for higher amperage single DC motor applications.

The four inputs (IN1 to IN4) can control DC motors in forward, reverse, brake, and coast modes, or a bipolar stepper motor in full- and half-step modes.

The A3909 is supplied in a 10-pin MSOP package with exposed thermal pad (suffix LY) and a 10-pin SSOP (suffix LN) for wave solder applications. Both packages are lead (Pb) free with 100% matte-tin leadframe plating.

### Functional Block Diagram

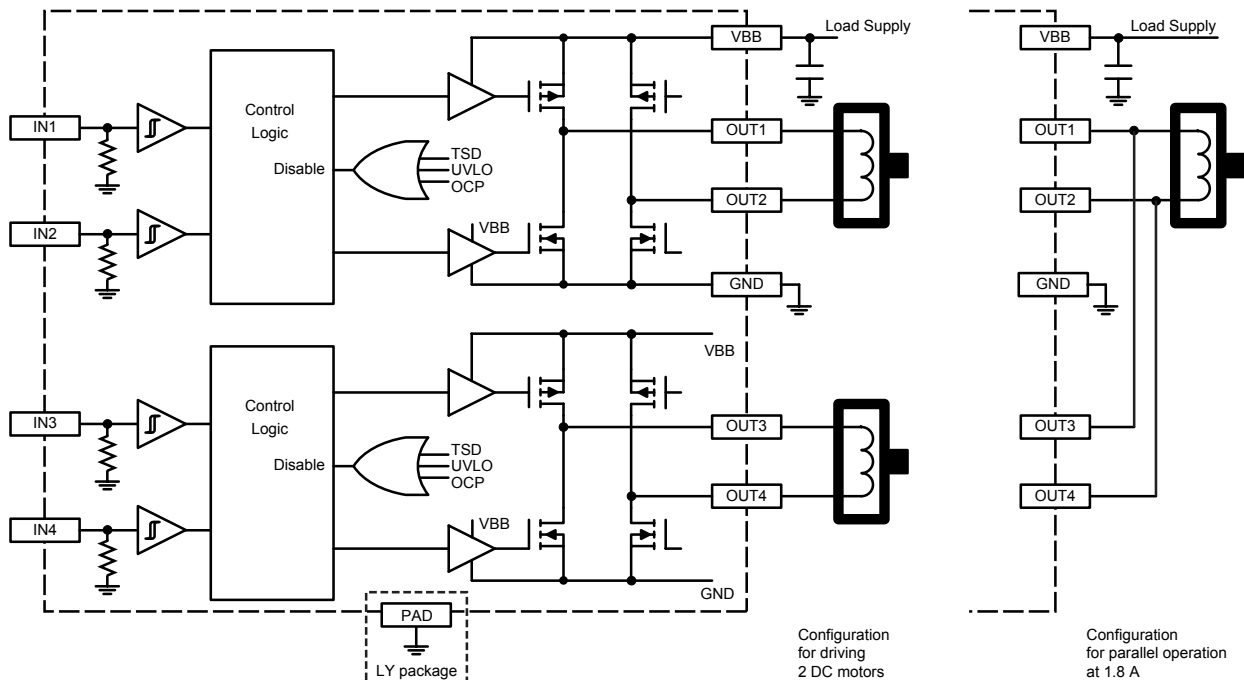

## SELECTION GUIDE

Part Number	Package	Packing
A3909GLNx-T*	10-pin SSOP	3000 pieces per 13-in. reel
A3909GLYTR-T	10-pin MSOP with exposed thermal pad	4000 pieces per 13-in. reel

\*Contact Allegro Sales for availability of this package option.

## ABSOLUTE MAXIMUM RATINGS

Characteristic	Symbol	Notes	Rating	Unit
Supply Voltage	$V_{BB}$		18	V
Logic Input Voltage Range	$V_{IN}$		-0.3 to 6	V
Output Current	$I_{OUT}$		1	A
Output Voltage	$V_{OUT}$		-0.3 to $V_{BB} + 1$	V
Operating Ambient Temperature	$T_A$	G temperature range	-40 to 105	°C
Maximum Junction Temperature	$T_{J(max)}$		150	°C
Storage Temperature	$T_{stg}$		-55 to 150	°C

**Thermal Characteristics** may require derating at maximum conditions, see application information

Characteristic	Symbol	Test Conditions*	Value	Unit
Package Thermal Resistance	$R_{\theta JA}$	LN package (estimated), on 1-layer PCB with copper limited to pin area	130	°C/W
		LY package, on 2-layer PCB with 2.260 in. <sup>2</sup> of copper area each side	48	°C/W

\*Additional thermal information available on the Allegro website.

## Terminal List Table

Number	Name	Function
1	IN1	Logic input
2	IN2	Logic input
3	VBB	Input supply
4	IN3	Logic input
5	IN4	Logic input
6	OUT4	Motor terminal
7	OUT3	Motor terminal
8	GND	Ground
9	OUT2	Motor terminal
10	OUT1	Motor terminal
-	PAD	(LY package) Exposed thermal pad

## Pinout Diagram

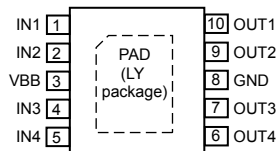

LN and LY packages

**ELECTRICAL CHARACTERISTICS\***: Valid at  $T_A = 25^\circ\text{C}$ , unless otherwise specified

Characteristic	Symbol	Test Conditions	Min.	Typ.	Max.	Unit
VBB Voltage Range	$V_{BB}$		4	–	18	V
VBB Supply Current	$I_{BB}$		–	4	8	mA
		Standby Mode	–	<1	10	$\mu\text{A}$
Total Driver On-Resistance (Sink + Source)	$R_{DS(on)tot}$	$I = 1\text{ A}, T_J = 25^\circ\text{C}, V_{BB} = 12\text{ V}$	–	1.6	2	$\Omega$
		$I = 1\text{ A}, T_J = 25^\circ\text{C}, V_{BB} = 4\text{ V}$	–	2.7	3.5	$\Omega$
Source Driver On-Resistance	$R_{DS(on)src}$	$I = 1\text{ A}, T_J = 25^\circ\text{C}, V_{BB} = 12\text{ V}$	–	1.12	–	$\Omega$
Sink Driver On-Resistance	$R_{DS(on)snk}$	$I = 1\text{ A}, T_J = 25^\circ\text{C}, V_{BB} = 12\text{ V}$	–	0.48	–	$\Omega$
Input Logic Low Level	$V_{IL(Standby)}$	All inputs low	–	–	0.4	V
Input Logic Low Level	$V_{IL}$		–	–	0.8	V
Input Logic High Level	$V_{IH}$		2	–	–	V
Input Hysteresis	$V_{HYS}$		100	300	500	mV
Logic Input Current	$I_{IN}$	$V_{IN} = 5\text{ V}$ (Pull down = 50 k $\Omega$ )	–	100	150	$\mu\text{A}$
VBB UVLO	$V_{BBUVLO}$	$V_{BB}$ rising	–	3.6	3.95	V
VBB UVLO Hysteresis	$V_{BBHYS}$		100	300	500	mV
Standby Timer	$t_{STB}$	$IN1 = IN2 = IN3 = IN4 < V_{IL(Standby)}$	–	1	1.5	ms
Thermal Shutdown Temperature	$T_{JTSD}$	Temperature increasing	150	165	180	$^\circ\text{C}$
Thermal Shutdown Hysteresis	$\Delta T_J$	Recovery = $T_{JTSD} - \Delta T_J$	–	20	–	$^\circ\text{C}$

\*Specified limits are tested at a single temperature and assured through operating temperature range by design and characterization.

Table 1: Motor Operation Truth Table

STEPPER MOTOR									
IN1	IN2	IN3	IN4	OUT1	OUT2	OUT3	OUT4	Function	
0	0	0	0	Off	Off	Off	Off	Sleep Mode	Sleep Mode
1	0	1	0	H	L	H	L	Step 1	Step 1
0	0	1	0	Off	Off	H	L	–	Step 2
0	1	1	0	L	H	H	L	Step 2	Step 3
0	1	0	0	L	H	Off	Off	–	Step 4
0	1	0	1	L	H	L	H	Step 3	Step 5
0	0	0	1	Off	Off	L	H	–	Step 6
1	0	0	1	H	L	L	H	Step 4	Step 7
1	0	0	0	H	L	Off	Off	–	Step 8
DC MOTORS (DUAL)									
IN1 or IN3		IN2 or IN4		OUT1	OUT2	OUT3	OUT4	Function	
0		0		Off	Off	Off	Off	High Impedance (Sleep Mode) / Coast	
1		0		H	L	H	L	Forward	
0		1		L	H	L	H	Reverse	
1		1		L	L	L	L	Brake	
DC MOTOR (SINGLE, PARALLELED)									
IN1 or IN3		IN2 or IN4		OUT1	OUT2	OUT3	OUT4	Function	
0		0		Off	Off	Off	Off	High Impedance (Sleep Mode) / Coast	
1		0		H	L	H	L	Forward	
0		1		L	H	L	H	Reverse	
1		1		L	L	L	L	Brake	
DC MOTOR (EXTERNAL PWM)									
IN1 or IN3		IN2 or IN4		OUT1	OUT2	OUT3	OUT4	Function	
1		0		H	L	H	L	Forward	
0		0		Off	Off	Off	Off	Fast Decay	
0		1		L	H	L	H	Reverse	
0		0		Off	Off	Off	Off	Fast Decay	
1		0		H	L	H	L	Forward	
1		1		L	L	L	L	Slow Decay	
0		1		L	H	L	H	Reverse	
1		1		L	L	L	L	Slow Decay	

NOTE: 0 = logic low with  $V_{INx} < V_{IN(0)}(\max)$ , 1 = logic high with  $V_{INx} > V_{IN(1)}(\min)$ , H = voltage high, source driver on, L = voltage low, sink driver on

## FUNCTIONAL DESCRIPTION

### Device Operation

The 3909 is designed to operate two DC motors or a single stepper motor. The outputs are PMOS source drivers combined with low  $R_{DS(on)}$  DMOS sink drivers.

Protection circuitry includes internal thermal shutdown, protection against shorted loads, and against outputs shorted to GND or supply. Undervoltage lockout prevents damage by keeping the outputs off until the driver has enough voltage to operate normally.

A low power standby (Sleep) mode is activated when all inputs are low for longer than 1 ms. Sleep mode disables all of the circuitry making the IC ideal for battery operated applications.

### Overcurrent Protection (OCP)

The A3909 is protected against accidental shorts or motor outputs to ground and supply, as well as a shorted load condition. For the source drivers, the current is monitored after the MOSFET is

turned on. If the current exceeds 1.8 A for longer than 2  $\mu$ s, then a fault condition is asserted. The sink driver utilizes a drain-to-source voltage monitor. If the voltage exceeds 2 V for longer than 2  $\mu$ s, the fault condition is asserted.

When a fault occurs, the IC immediately disables both sides of the full bridge where the fault occurred. The full bridge input commands will be ignored for a 2 ms period before being allowed to retry. Each channel has independent overcurrent protection.

During OCP events, the absolute ratings may be exceeded for a short period of time before the outputs are disabled.

### Thermal Shutdown

If the die temperature increases to  $T_{JTSD}$ , then all outputs are disabled until the internal temperature falls below a hysteresis level,  $T_{TSDHYS}$ , of 20°C. Internal UVLO is detected on VBB to prevent output drivers from turning on when below the UVLO threshold.

DC Motor Timing Diagram

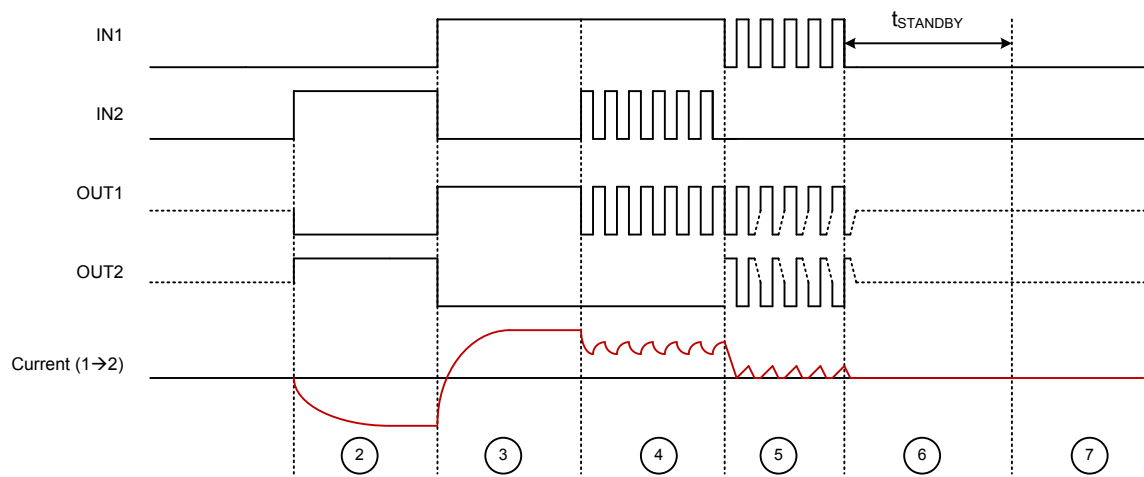

- |  |                                      |
|--|--------------------------------------|
| 1) Low power standby (Sleep) mode ( $I_{BB} = 0$ ) | 5) Fast decay PWM                    |
| 2) On, reverse – 100% duty cycle                   | 6) Coast                             |
| 3) On, forward – 100% duty cycle                   | 7) Low power standby (Sleep) mode    |
| 4) Slow decay PWM                                  | after $t_{STANDBY}$ ( $I_{BB} = 0$ ) |

Stepper Motor Timing Diagram

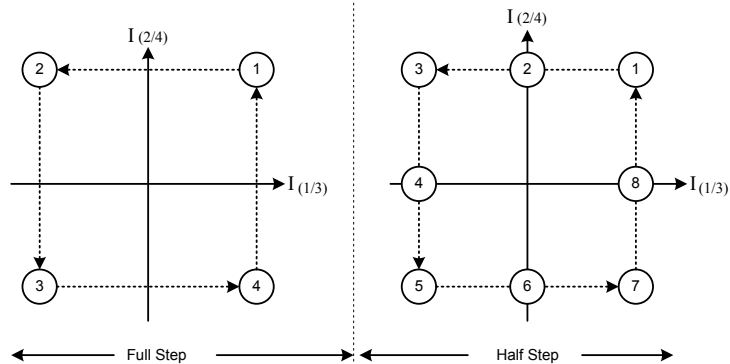
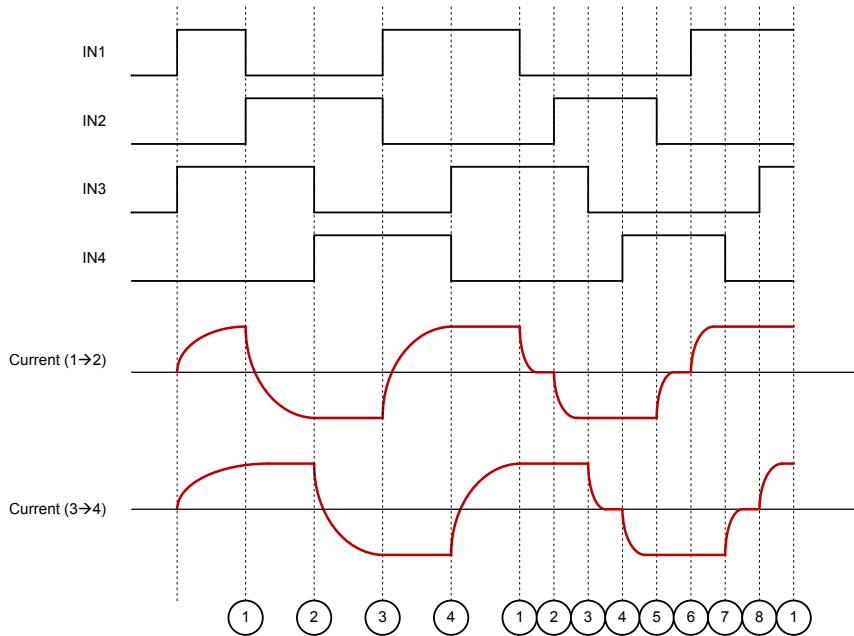
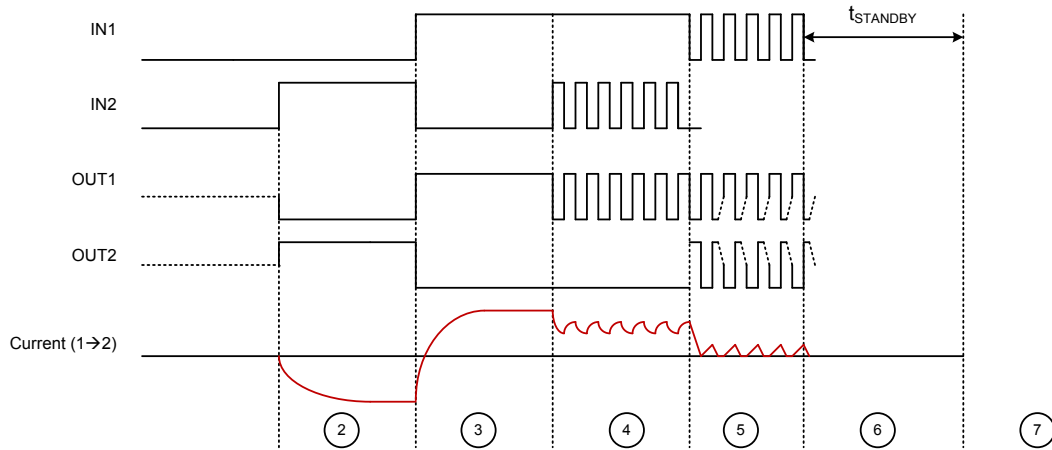

APPLICATION INFORMATION

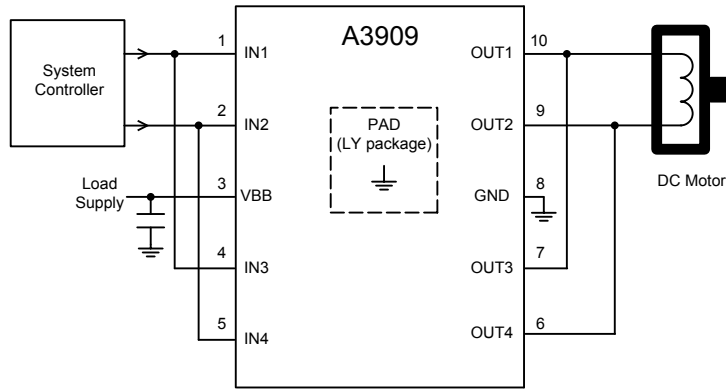

Configuration for parallel operation with 1.8 A output current capability

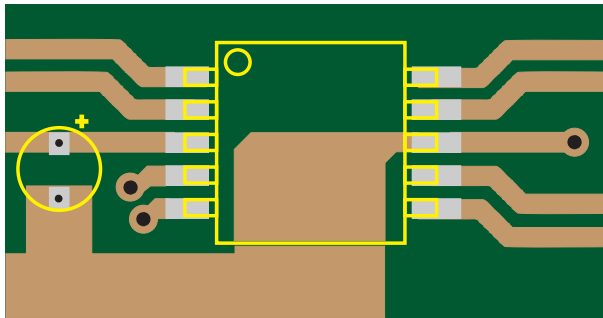

LN package board

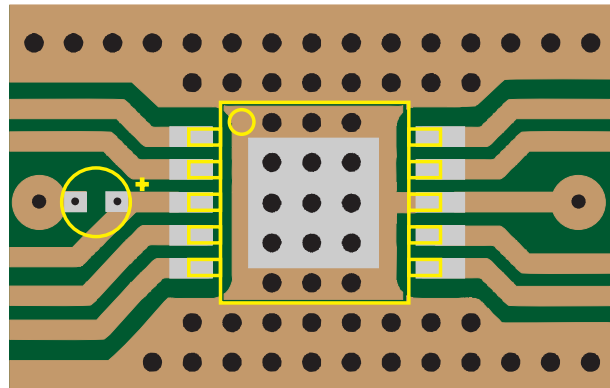

LY package board via layout for thermal dissipation

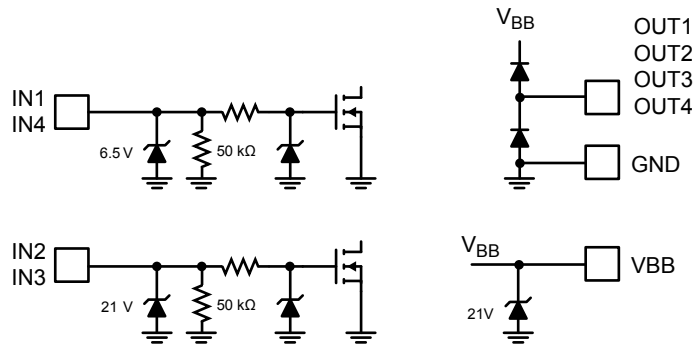

Input Output Pin Structures

Package LN, 10-Pin SSOP

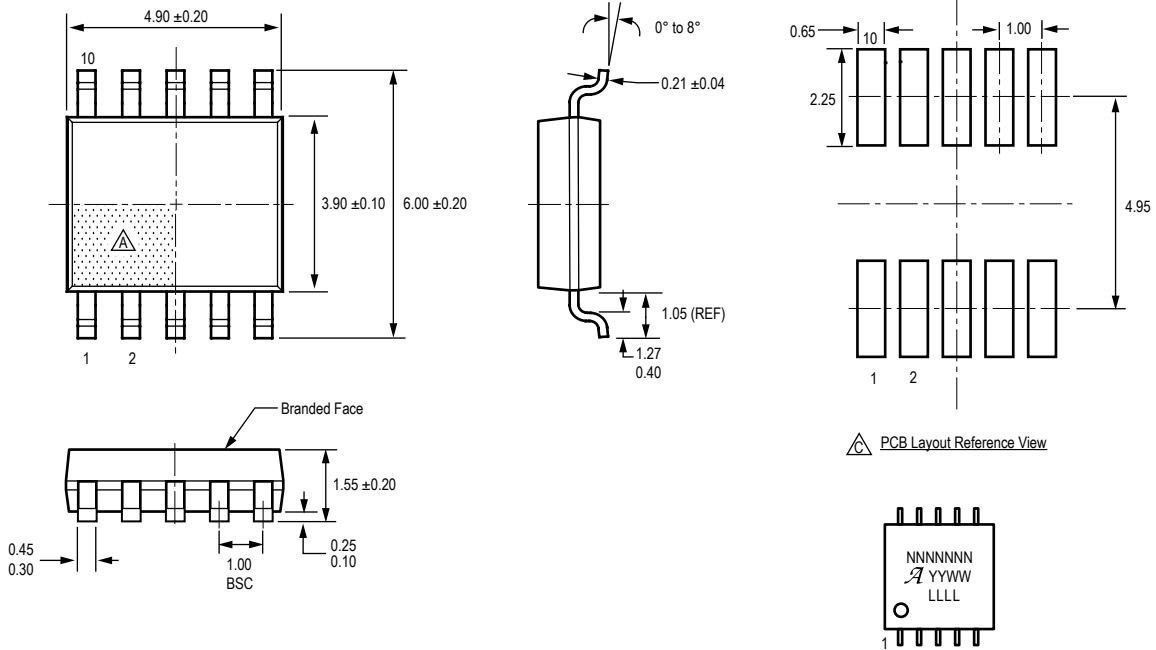

For Reference Only; not for tooling use  
 Dimensions in millimeters  
 Dimensions exclusive of mold flash, gate burrs, and dambar protrusions  
 Exact case and lead configuration at supplier discretion within limits shown

- Terminal #1 mark area
- Branding scale and appearance at supplier discretion
- Reference land pattern layout. All pads a minimum of 0.20 mm from all adjacent pads; adjust as necessary to meet application process requirements and PCB layout tolerances; when mounting on a multilayer PCB, thermal vias near the pin lands can improve thermal dissipation (reference EIA/JEDEC Standard JESD51-7)

Standard Branding Reference View

N = Device part number  
 A = Supplier emblem  
 Y = Last two digits of year of manufacture  
 W = Week of manufacture  
 L = Lot number



Package LY, 10-Pin MSOP  
With Exposed Thermal Pad

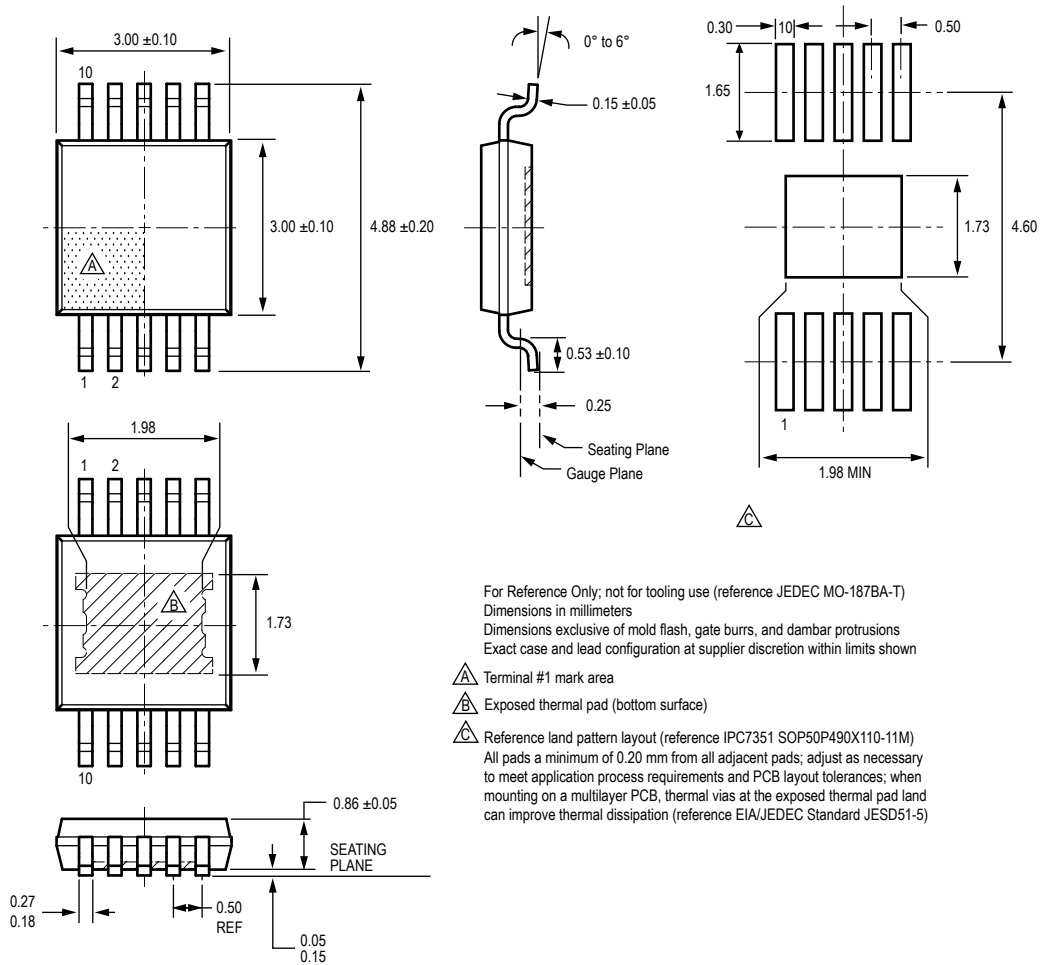

**Revision History**

Number	Date	Description
-	November 15, 2018	Corrected Output Current units in Absolute Maximum Ratings table (page 2)

Copyright ©2018, Allegro MicroSystems, LLC

Allegro MicroSystems, LLC reserves the right to make, from time to time, such departures from the detail specifications as may be required to permit improvements in the performance, reliability, or manufacturability of its products. Before placing an order, the user is cautioned to verify that the information being relied upon is current.

Allegro's products are not to be used in any devices or systems, including but not limited to life support devices or systems, in which a failure of Allegro's product can reasonably be expected to cause bodily harm.

The information included herein is believed to be accurate and reliable. However, Allegro MicroSystems, LLC assumes no responsibility for its use; nor for any infringement of patents or other rights of third parties which may result from its use.

Copies of this document are considered uncontrolled documents.

For the latest version of this document, visit our website:

[www.allegromicro.com](http://www.allegromicro.com)