



ON Semiconductor®

<http://onsemi.com>

LC898301AXA

Advance Information

CMOS LSI

Liner Vibrator Driver IC

Overview

The LC898301AXA is a Linear Vibrator Driver IC dedicated to haptic feedback actuator and vibrator employed in mobile equipment. Due to the product superior technology, the drive frequency is automatically adjusted to the resonance frequency of the linear vibrator without the use of other external parts. As a result of this very effective drive, the vibration is as powerful as possible using very limited amount of energy compared to classical solutions. The start time and brake time are fully configurable through the I²C setting. Moreover, an automatic braking function has been implemented allowing to optimize the braking time.

Finally, a self test mode allows to detect various possible functional defaults during assembly.

Feature

- 1) Automatic adjustment to the resonance frequency for LRA (150Hz to 385Hz)
- 2) Programmable or Automatic braking
- 3) Initial drive frequency adjustment function
- 4) Adjustable Drive voltage through I²C IF setting
- 5) EN IF or PWM IF driving mode available by automatic detection
- 6) Support various drive pattern through I²C (1.8V IF)
- 7) Low power consumption thanks to the highly effective drive and the low power driving mode
- 8) Low driving noise (EMI, Audible band)
- 9) VBAT compliant
- 10) Thermal shutdown protection
- 11) Self test mode for defaults detection (open-circuit, short-circuit and weak back EMF)

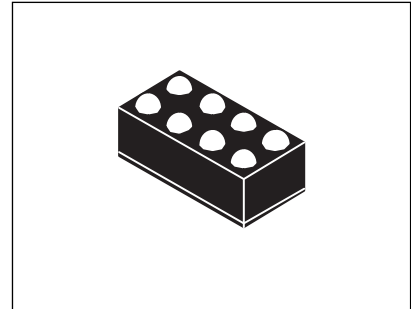

WLCSP8, 0.78x1.58

Applications

- 1) Linear Vibrator (Vibration and haptics)
- 2) Mobile Phone
- 3) Portable Game
- 4) Mobile equipment with haptics function

* I²C Bus is a trademark of Philips Corporation.

This document contains information on a new product. Specifications and information herein are subject to change without notice.

ORDERING INFORMATION

See detailed ordering and shipping information on page 12 of this data sheet.

LC898301AXA

Block Diagram

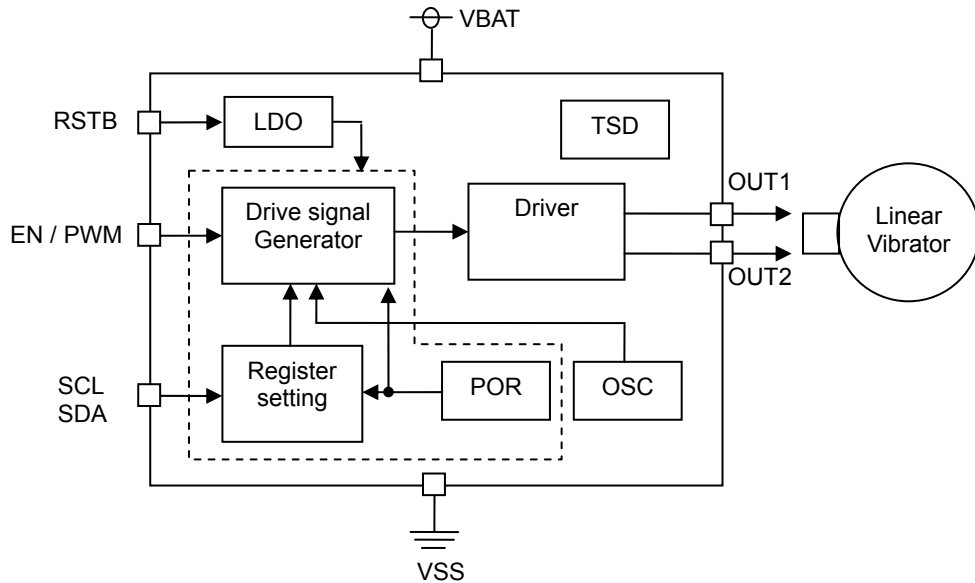

Fig. 1

Absolute Maximum Ratings at $V_{SS} = 0V$

Parameter	Symbol	condition	Rating	Unit
Supply voltage range	V_{DDmax}		-0.3 to 6.0	V
Input voltage	V_{I1}	*1	-0.3 to $V_{DD}+0.3$	V
	V_{I2}	*2	-0.3 to 3.3	V
Output voltage	V_O	*3	-0.3 to 3.3	V
H-bridge Drive current	I_{Omax}		200	mA
Allowable power dissipation	PD_{max}	$T_a=85\text{ }^\circ\text{C}$, *4	140	mW
Operating temperature range	T_a		-30 to 85	$^\circ\text{C}$
Storage temperature range	T_{stg}		-55 to 125	$^\circ\text{C}$
Input or Output current	I_I, I_O	*5	± 20	mA

*1 RSTB pin

*2 EN, SDA, SCL pins

*3 SDA pin

*4 glass epoxy (50mm × 40mm, $t=0.9\text{mm}$, FR-4)

*5 Per an I/O buffer

Stresses exceeding Maximum Ratings may damage the device. Maximum Ratings are stress ratings only. Functional operation above the Recommended Operating Conditions is not implied. Extended exposure to stresses above the Recommended Operating Conditions may affect device reliability.

Recommended Operating Conditions at $T_a = -30$ to $85\text{ }^\circ\text{C}$, $V_{CC} = 0V$

Parameter	Symbol	condition	Min	Typ	Max	Unit
Supply voltage range	V_{DD}		3.0	-	5.5	V
Input voltage range	V_{IN1}	*1	0	-	V_{DD}	V
	V_{IN2}	*2	0	-	1.98	V

*1 RSTB pin

*2 EN, SDA, SCL pins

LC898301AXA

Electric Characteristics

DC Characteristics at $V_{SS} = 0V$, $V_{DD} = 3.0$ to $5.5V$, $T_a = -30$ to $+85\text{ }^\circ\text{C}$

Parameter	Symbol	Condition	Min	Typ	Max	Unit	Applied pin
High level Input voltage	V_{IH}	CMOS	1.40	-	-	V	EN
Low level Input voltage	V_{IL}		-	-	0.32	V	
High level Input voltage	V_{IH}	CMOS Schmitt	1.50	-	-	V	SDA,SCL
Low level Input voltage	V_{IL}		-	-	0.24	V	
High level Input voltage	V_{IH}	CMOS Schmitt	1.50	-	-	V	RSTB
Low level Input voltage	V_{IL}		-	-	0.36	V	
Low level output voltage	V_{OL}	$I_{OL}=4mA$	-	-	0.4	V	SDA
Input leakage current	I_{IL}	$V_i=V_{DD},V_{SS}$	-10	-	+10	μA	RSTB,EN SDA,SCL

AC Input Characteristics at $V_{SS} = 0V$, $V_{DD} = 3.0$ to $5.5V$, $T_a = -30$ to $+85\text{ }^\circ\text{C}$

Parameter	Symbol	Min	Typ	Max	Unit	Condition
Input PWM frequency	f_{frq}	10.0	-	50.0	kHz	1%<PWM Duty<99%

Power Consumption at $V_{SS} = 0V$, $V_{DD} = 3.0$ to $5.5V$, $T_a = 25\text{ }^\circ\text{C}$

Parameter	Symbol	Min	Typ	Max	Unit	Condition
Stand-by current	P_{stb}	-	0.04	2.0	μA	RSTB="0"
Idle current	P_{idl}	-	2.7	-	mA	RSTB="1", EN="0"

Analog Characteristics at $V_{SS} = 0V$, $V_{DD} = 3.7V$, $T_a = 25\text{ }^\circ\text{C}$

Parameter	Symbol	Min	Typ	Max	Unit	Condition
Output Voltage Difference OUT1 from OUT2	V_{out12}	-	2.7	-	Vpp	HBPW=max, VOSEL="00"
		-	2.9	-	Vpp	HBPW=max, VOSEL="01"
Adjustable resonance frequency range	F_{mo}	-10	-	+10	%	vs typ value

LC898301AXA

Pin Assignment

Pin List

I/O -> I : input, O: output, B: bi-direction, P: power supply, NC: not connected

NO	NAME	I/O	NO	NAME	I/O
1A	OUT1	O	1B	VDD	P
2A	OUT2	O	2B	RSTB	I
3A	GND	P	3B	EN	I
4A	SCL	I	4B	SDA	B

Pin Layout (PKG : WLP8, 0.4mm pitch)

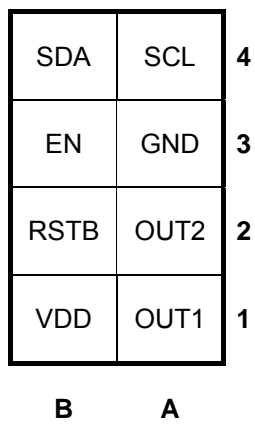

< Bottom View >

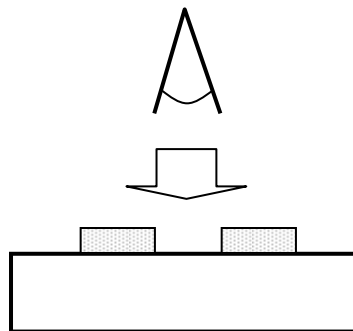

Fig.5

Timing Chart

Motor drive timing

The EN or PWM input mode is detected automatically after RSTB pin is set to "H". IF the input mode detection is completed, the result is maintained until RSTB is set to "L".

EN control mode

The Motor is controlled by EN signal, and the driving time is controlled by keeping EN pin "H". The High speed start UP time, driving power and Brake time can be modified by I²C setting. The initial driving frequency must be set by I²C I/F at the center of resonance frequency of the linear vibrators, when the initial driving frequency is inadequate. The minimum width of EN signal must be larger than the cycle of initial driving frequency setting.

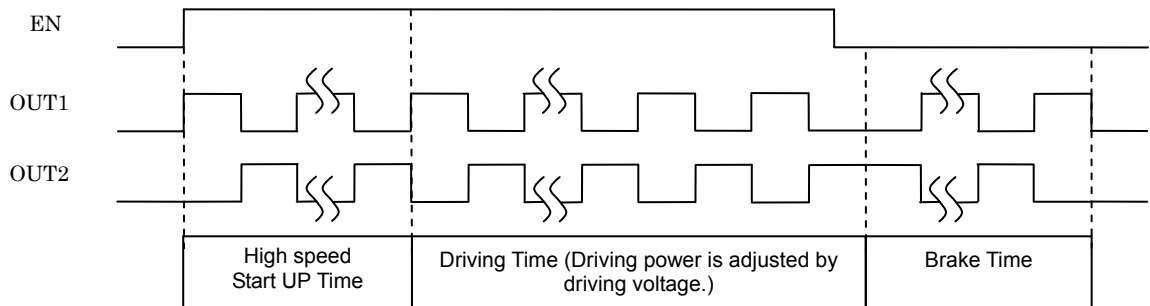

Fig 8.1

Stand-by Control (EN control mode)

The Stand-by mode is controlled by RSTB pin. (RSTB="L" → Stand-by mode is ON.)

When the stand-by mode is "ON", the register value is set to initial value. So, the register must be set again after the stand-by mode is "OFF". And, the "EN" signal and I²C command must wait over 200μs after "RSTB" pin is set to "H".

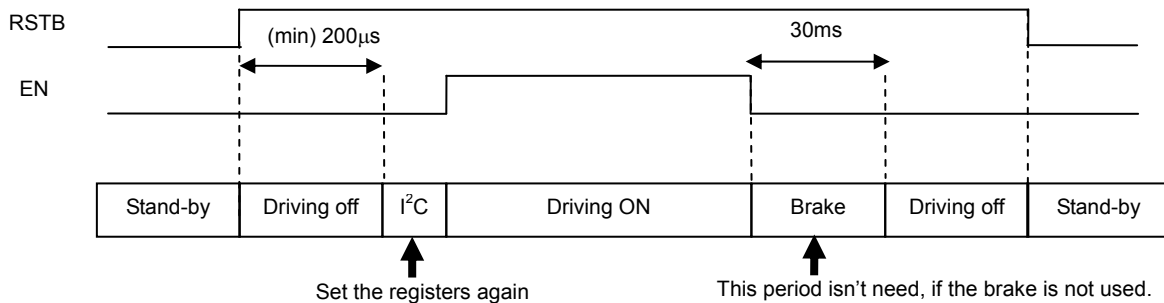

Fig 8.2

EN control

The minimum time of EN="H" is (1/ the frequency: RESOFRQ). ex) 0x02 RESOFRQ=0x0A (175Hz) → (min) 5.71ms
 EN="L" just after EN="H" means brake works. So the minimum time of EN="L" depends on the remains of vibration. Then when drive time until just before EN="L"(time of EN="H" before EN="L") is over 30msec, the minimum time of EN="L" is 30msec.

When drive time until just before EN="L"(time of EN="H" before EN="L") is less than 30msec, the minimum time of EN="L" is the same time as drive time until just before EN="L".

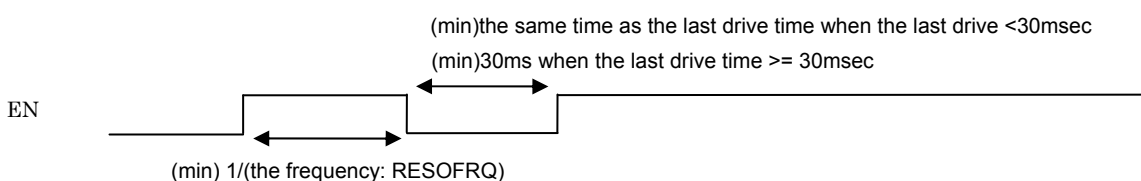

Fig 8.3

PWM control mode

On this mode the motor is controlled by “PWM” signal, and it is automatically detected. The driving or brake mode is judged by the duty of “PWM” signal. Also the driving power is judged by it. The judgment rule is decided by the table as below. On this mode, 0x05 to 0x09 registers are available, and the PWM input duty is limited between 1% to 99%. When the duty is 0%, the driving is stopped.

Note) PWM input frequency must be set $128 * (\text{Resonance frequency of LRA})$ in case 0x08:RFSEL is set to "0".

Note) The actual driving frequency of the LRA is calculated by Auto Tune function.

Note) The period of input PWM detection is about 170μs after a signal input.

Duty(%)	Driving mode	resolution
99.00 to 50.39	Forward	127 steps
50.39 to 49.62	Stop	-
49.62 to 1.00	Reverse	127steps

Note) Duty:99.0% is maximum driving, on the other hand, Duty:1.0% is maximum braking.

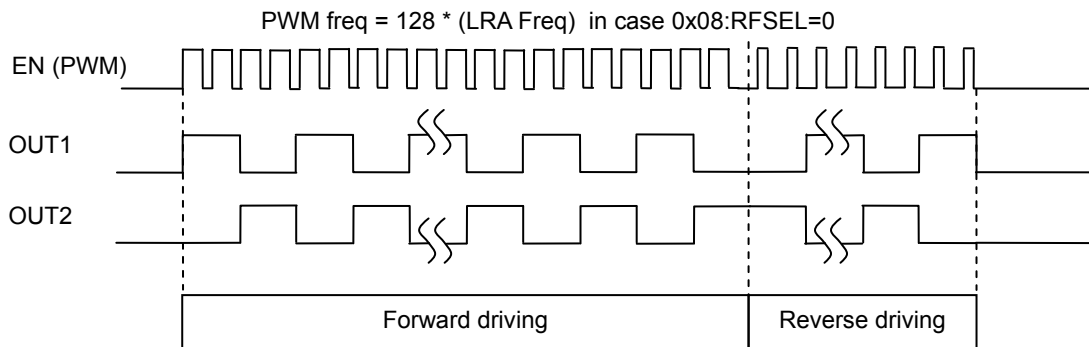

Fig.8.4

Stand-by Control (PWM control mode)

The Stand-by mode is controlled by RSTB pin. (RSTB="L" → Stand-by mode is ON.)

When the stand-by mode is “ON”, the register value is set to initial value. So, the register must be set again after the stand-by mode is “OFF”. And, the “EN” signal and I²C command must wait over 200μs after “RSTB” pin is set to “H”.

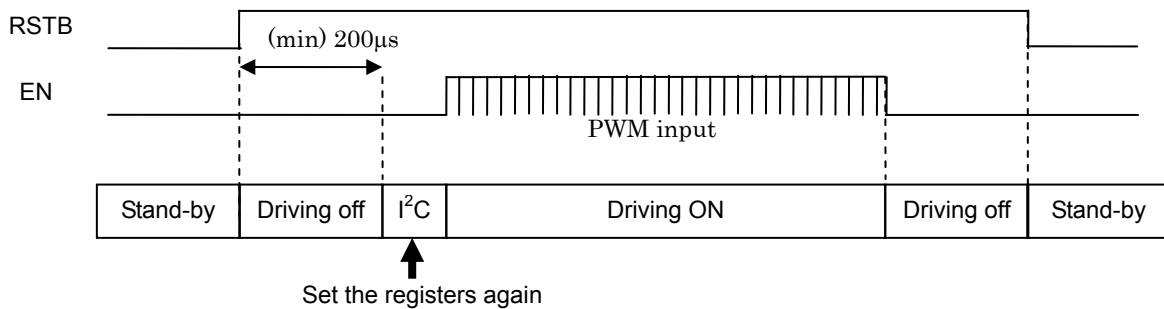

Fig 8.5

I²C Serial Interface

Writing format (Sequential Writing is possible)

After the start condition, slave address (7bit) and “L”(Write mode) are received , the flag “ACK=L” is replied. Next, after the 8bit address is received, the flag “ACK=L” is replied. Next, after the 8bit write data is received, the flag “ACK=L” is replied. Next, when the stop condition is received, the write data can be written in the specified address. Moreover, it is possible to write data in the incremental address by the continuous input of the 8bit data confirming the flag “ACK=L” after the every 8bit write data input.

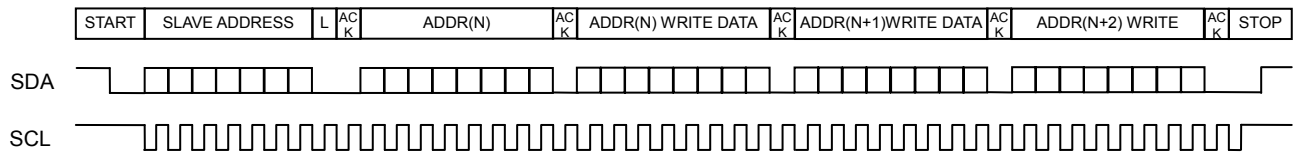

Fig 8.6

Reading format (Sequential Reading is possible)

After the dummy writing, the start condition, slave address(7bit) and “H”(Read mode) are received, the flag “ACK=L” is replied. Next, the 8bit read data is output. After them, when the stop condition is not received, and the read condition is continued, the read data of incremental address is output one by one. The read condition is end when the end condition is received after the flag “ACK=H”.

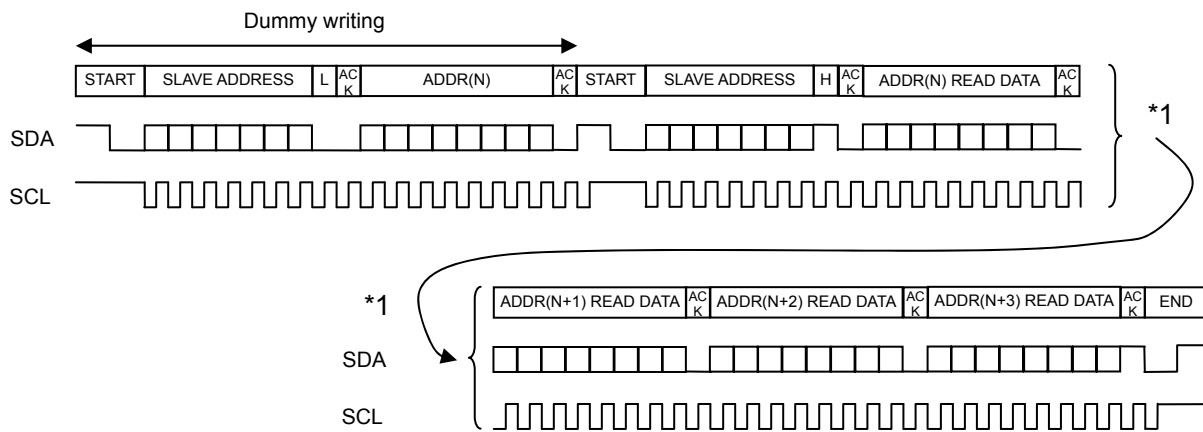

Fig 8.7

Slave Address

The Slave Address is as follows.

Slave Address	1001001
---------------	---------

LC898301AXA

AC Characteristics (I²C Serial Interface) at V_{SS}=0V, V_{DD}=3.0 to 5.5V, Ta=-30 to +85°C

Parameter	Symbol	Pin	Min	Typ	Max	Unit	comment
SCL Clock Frequency	f _{SCL}	SCL	-	-	400	kHz	
START condition Hold time	t _{HD;STA}	SCL SDA	0.6	-	-	μs	
SCL clock Low width	t _{LOW}	SCL	1.3	-	-	μs	
SCL clock High width	t _{HIGH}	SCL	0.6	-	-	μs	
RE-START condition Setup time	t _{SU;STA}	SCL SDA	0.6	-	-	μs	
SDA Hold time	t _{HD;DAT}	SCL SDA	0	-	-	μs	
SDA Setup time	t _{SU;DAT}	SCL SDA	0.2	-	-	μs	*1
SDA, SCL Rise time	t _r	SCL SDA		-	0.3	μs	*1
SDA, SCL Fall time	t _f	SCL SDA		-	0.3	μs	*1
STOP condition Setup time	t _{SU;STP}	SCL SDA	0.6	-	-	μs	
STOP to START BUS open time	t _{BUF}	SCL SDA	1.3	-	-	μs	

*1) Design Assurance (Shipment test none)

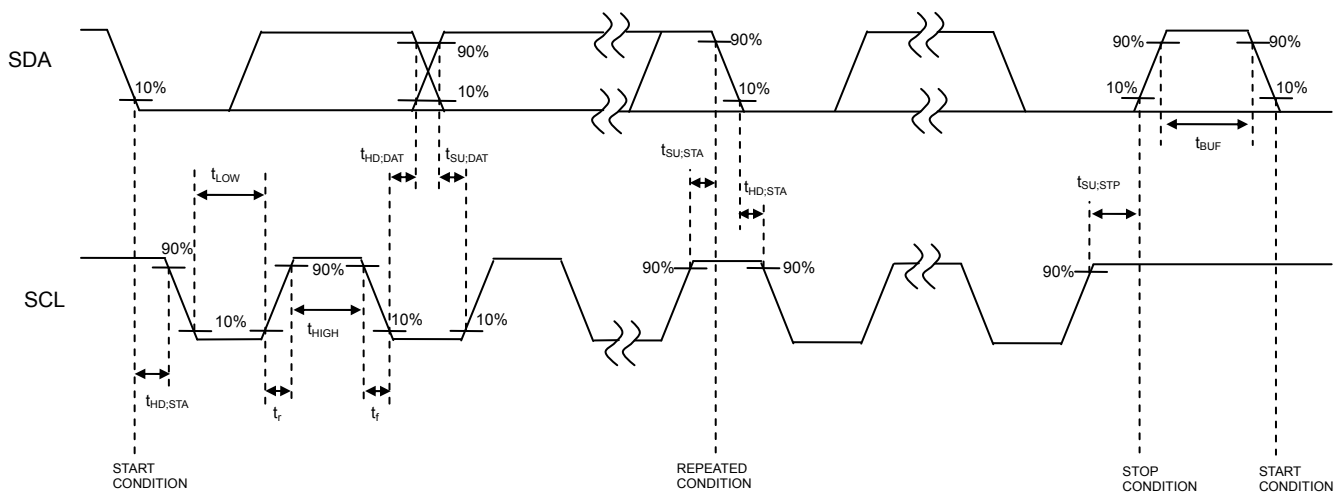

Fig 8.8

AC Characteristic (Power On Reset) at V_{SS}=0V, V_{DD}=3.0 to 5.5V, Ta=-30 to +85°C

Parameter	Symbol	Min	Typ	Max	Unit	comment
RSTB input timing	T _{RSTB}	1.0	-	-	μs	-

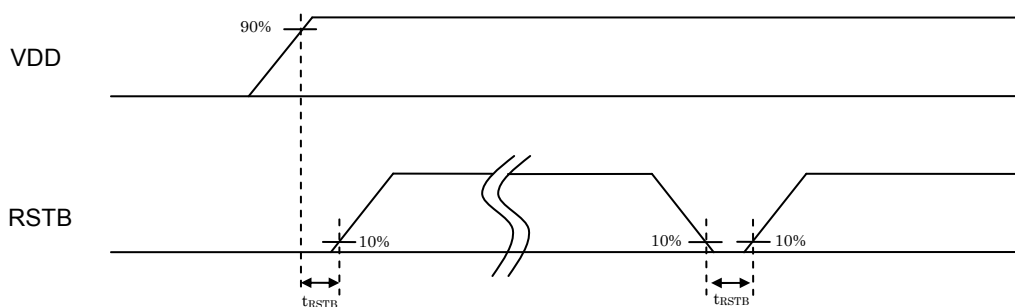
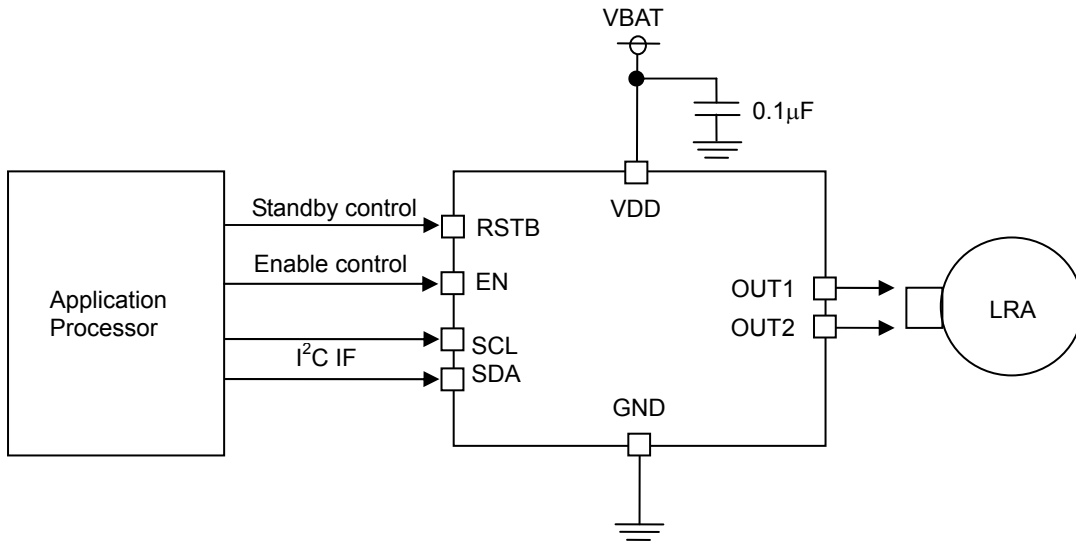

Fig 8.9 RSTB input timing chart

Application Information

1) A vibration is controlled by EN & RSTB pin.



2) A vibration is controlled by PWM input RSTB pin.

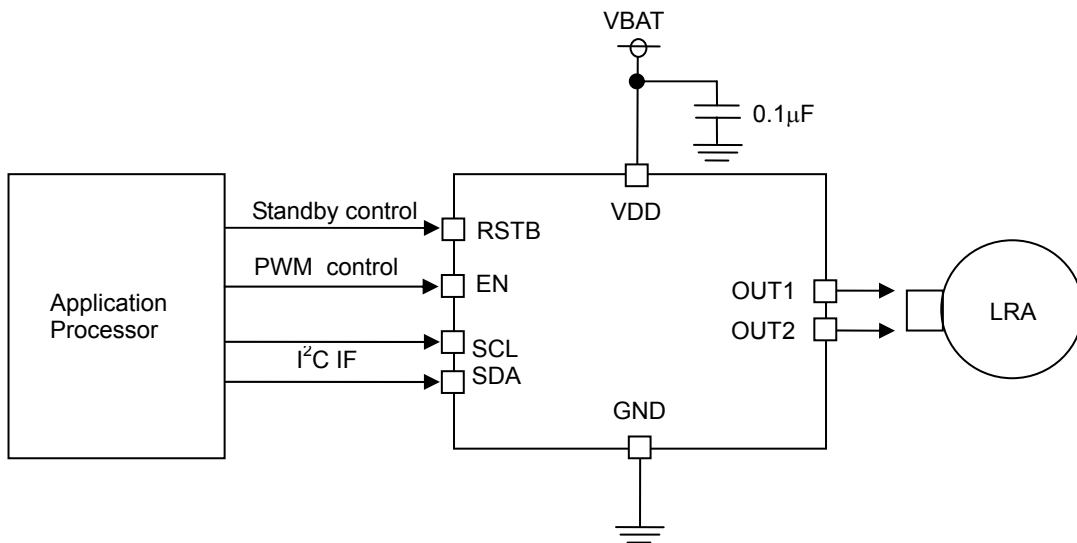

3) A vibration is controlled by 0x09 ENON register.

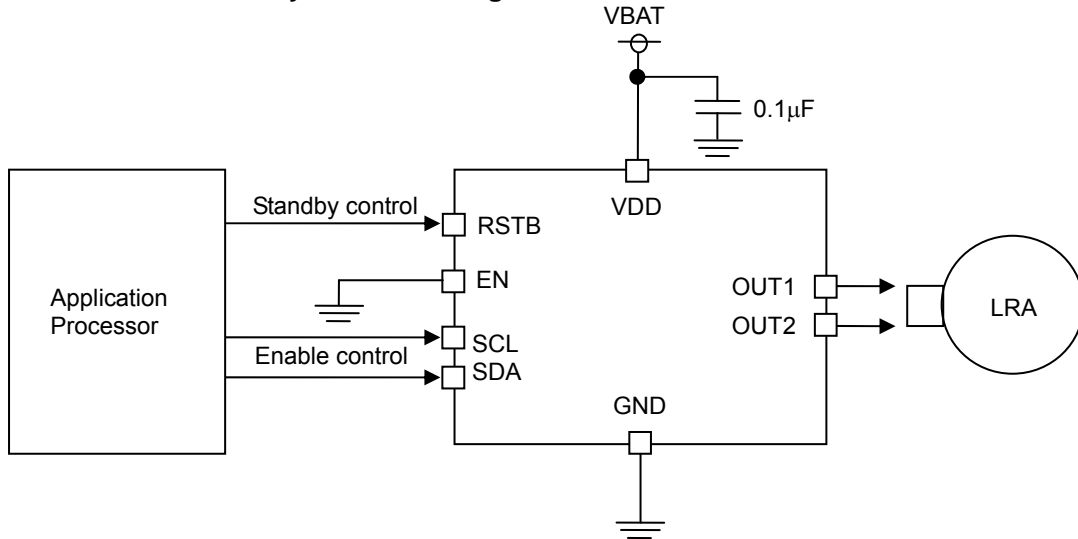

4) A vibration is controlled by RSTB pin only.

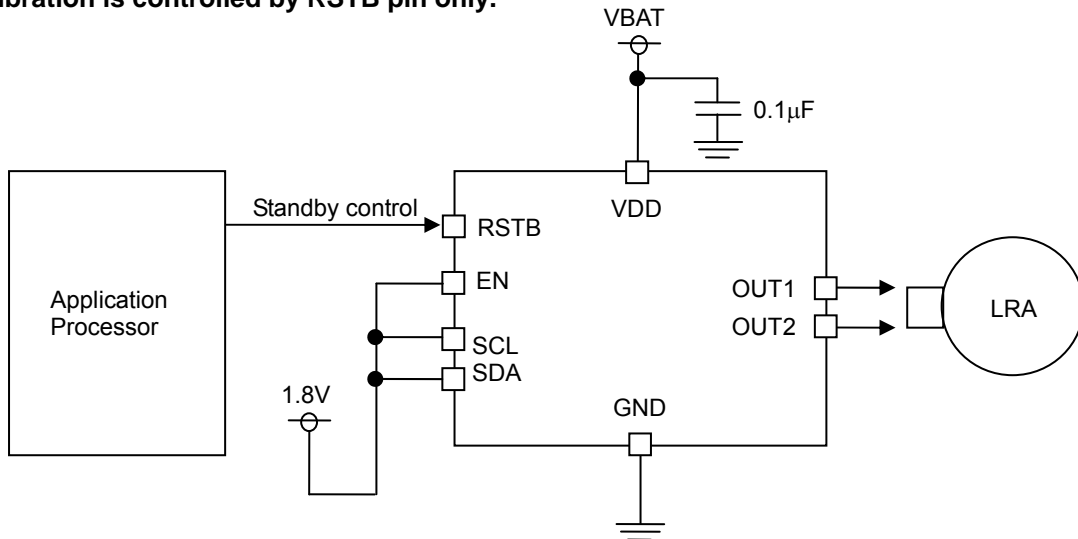

5) A vibration is controlled by VDD supply only.

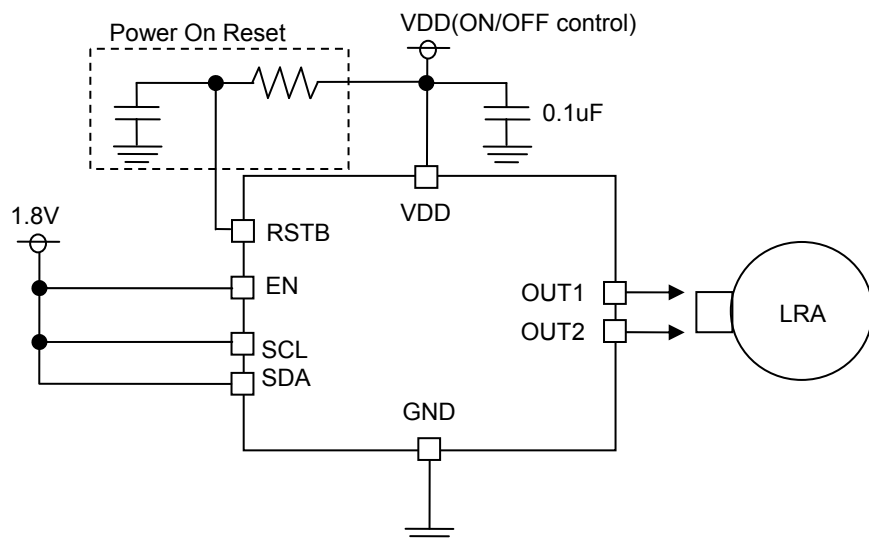

LC898301AXA

ORDERING INFORMATION

Device	Package	Shipping (Qty / Packing)
LC898301AXA-MH	WLCSP8, 0.78x1.58 (Pb-Free / Halogen Free)	5000 / Tape & Reel

ON Semiconductor and the ON logo are registered trademarks of Semiconductor Components Industries, LLC (SCILLC). SCILLC owns the rights to a number of patents, trademarks, copyrights, trade secrets, and other intellectual property. A listing of SCILLC's product/patent coverage may be accessed at www.onsemi.com/site/pdf/Patent-Marking.pdf. SCILLC reserves the right to make changes without further notice to any products herein. SCILLC makes no warranty, representation or guarantee regarding the suitability of its products for any particular purpose, nor does SCILLC assume any liability arising out of the application or use of any product or circuit, and specifically disclaims any and all liability, including without limitation special, consequential or incidental damages. "Typical" parameters which may be provided in SCILLC data sheets and/or specifications can and do vary in different applications and actual performance may vary over time. All operating parameters, including "Typicals" must be validated for each customer application by customer's technical experts. SCILLC does not convey any license under its patent rights nor the rights of others. SCILLC products are not designed, intended, or authorized for use as components in systems intended for surgical implant into the body, or other applications intended to support or sustain life, or for any other application in which the failure of the SCILLC product could create a situation where personal injury or death may occur. Should Buyer purchase or use SCILLC products for any such unintended or unauthorized application, Buyer shall indemnify and hold SCILLC and its officers, employees, subsidiaries, affiliates, and distributors harmless against all claims, costs, damages, and expenses, and reasonable attorney fees arising out of, directly or indirectly, any claim of personal injury or death associated with such unintended or unauthorized use, even if such claim alleges that SCILLC was negligent regarding the design or manufacture of the part. SCILLC is an Equal Opportunity/Affirmative Action Employer. This literature is subject to all applicable copyright laws and is not for resale in any manner.

Mouser Electronics

Authorized Distributor

Click to View Pricing, Inventory, Delivery & Lifecycle Information:

[ON Semiconductor:](#)

[LC898301AXA-MH](#)