

REVISIONS				
P	LTR	DESCRIPTION	DATE	BY
Z4		REVISED PER ECR-17-011770	28AUG2017	N.L. D.Z

- 1 POST TO WITHSTAND 13 NEWTONS (3 LBS) MIN. AXIAL FORCE BOTH DIRECTIONS SHOWN WITHOUT DISLODGING.
- 2 TOLERANCES APPLY TO SOLDER SIDE OF BOARD.
- 3 MEASURED AT SURFACE -A-
- 4 PLASTIC FLASH PERMITTED IN THIS AREA.
- 5 PARTS COMPLY WITH AMP SOLDERABILITY SPEC. NO. TEC-109-11-12-1.
- 6 ONE HOLE MAY BE UNDERSIZED (.032-.035 DIA) FOR ASSEMBLY RETENTION DURING WAVE SOLDERING.
- 7 MATERIAL: HEADER-THERMOPLASTIC POLYESTER UL94V-0(NATURAL) POST-COPPER ALLOY (SEE NOTES 13 & 14 FOR PLATING)
- 8 COORDINATE DIMENSION APPLIES FROM CENTER OF ACTUAL FEATURE.
- 9 PLASTIC BURRS CAUSED BY CUT-OFF TOOLING ARE PERMITTED WITHIN THE MAXIMUM TOLERANCE ENVELOPE.
- 10 POSTS TO BE MEASURED WHEN STRIP IS HELD FLAT.
- 11 POSTS MUST WITHSTAND TWO 90° BENDS AGAINST EXTRUSION WITHOUT BREAKING.
- 12 DIMENSION SHOULD BE .130 MIN WHEN MATING WITH A MTA 100 CONNECTOR ASSEMBLY OR A CST 100 CONNECTOR.
- 13 PLATING: GOLD PLATE AREA, .000030 GOLD OR .000003 MIN GOLD FLASH OVER .000027 PALLADIUM NICKEL, PER TE CONNECTIVITY'S DISCRETION, ALL SIDES, OVER NICKEL UNDERPLATE, .000050 MIN, ALL SIDES AND ENTIRE LENGTH OF POST.
- 14 MATTE TIN PLATE AREA, .000150-.000350 THICK, ALL FOUR SIDES, .140 MIN.
- 15 TIN PLATE AREA, .000150-.000350 THICK, ALL FOUR SIDES, .140 MIN.
- 16 OBSOLETE PARTS: OBSOLETE CIS STREAMLINING PER D.RENAUD/D.SINISI

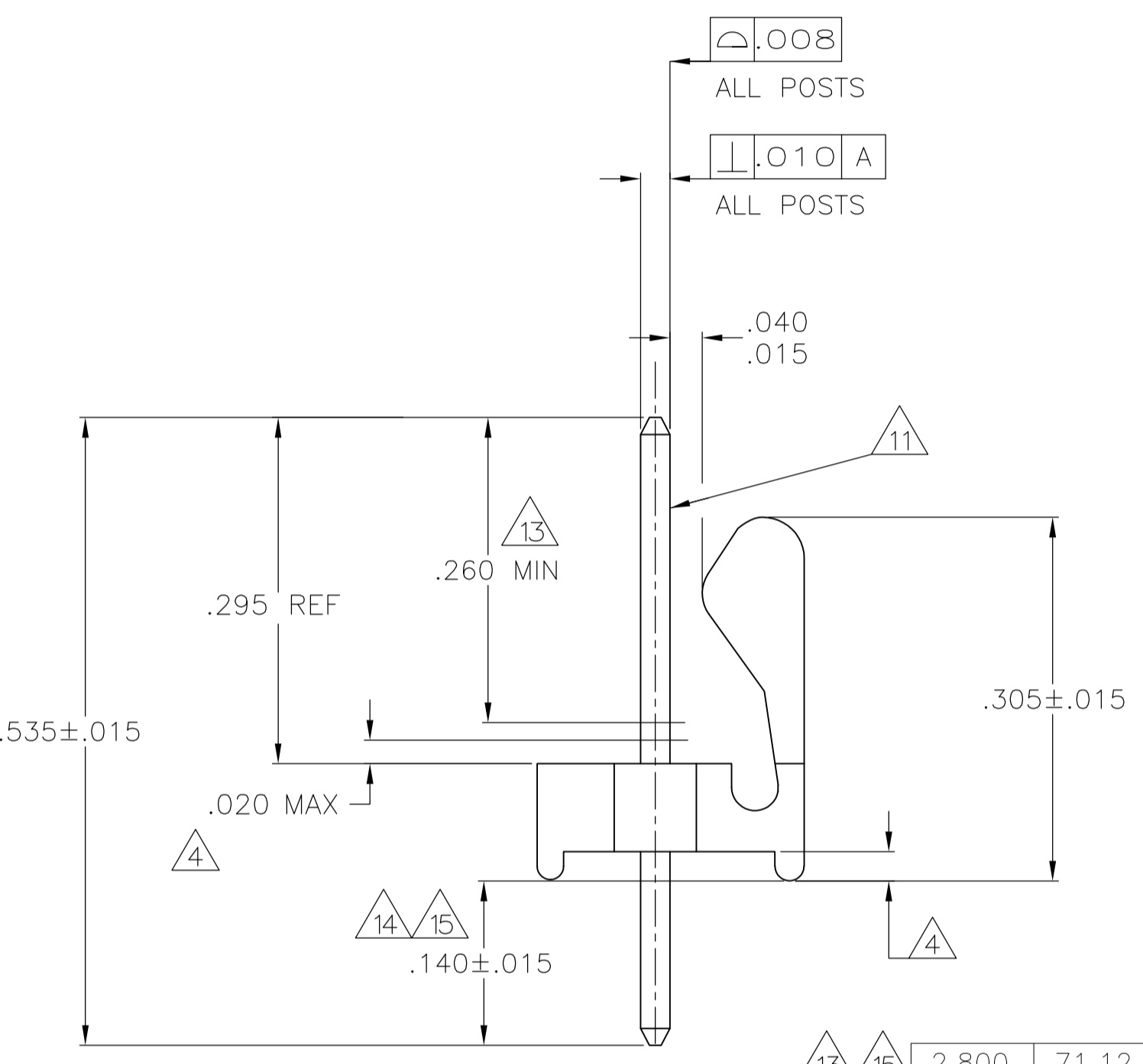

IN	MM	IN	MM
.040	1.02		
.035	0.89		
.032	0.81		
.025	0.64	1.000	125.40
.020	0.51	.535	13.59
.015	0.38	.310	7.87
.010	0.25	.295	7.49
.008	0.20	.260	6.60
.005	0.13	.225	5.72
.001	0.03	.140	3.56
.000350	0.00889	.130	3.30
.000150	0.00381	.125	3.18
.000050	0.00127	1.100	2.54
.000030	0.00076	.063	1.60
.000	0.00	.050	1.27

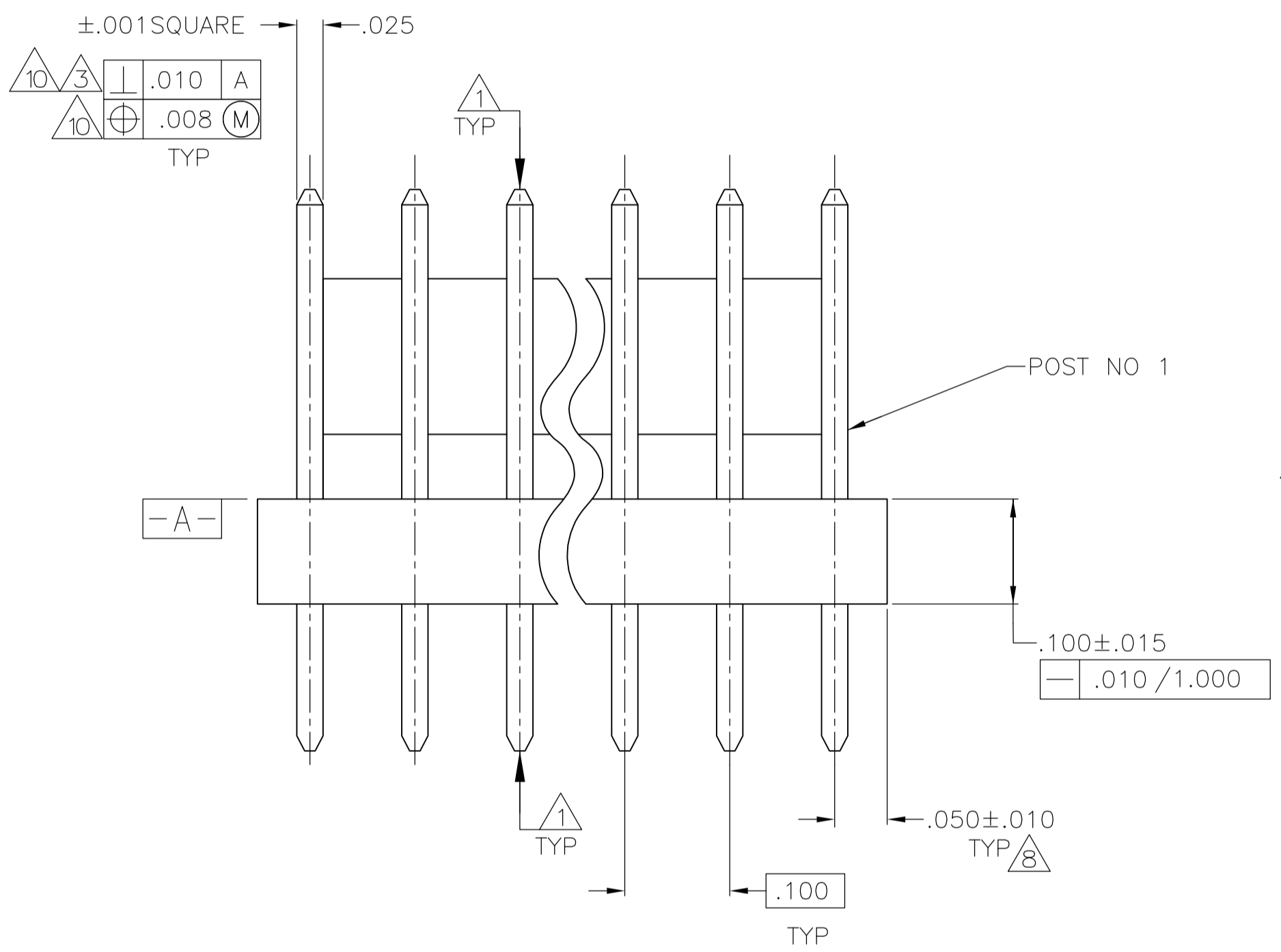
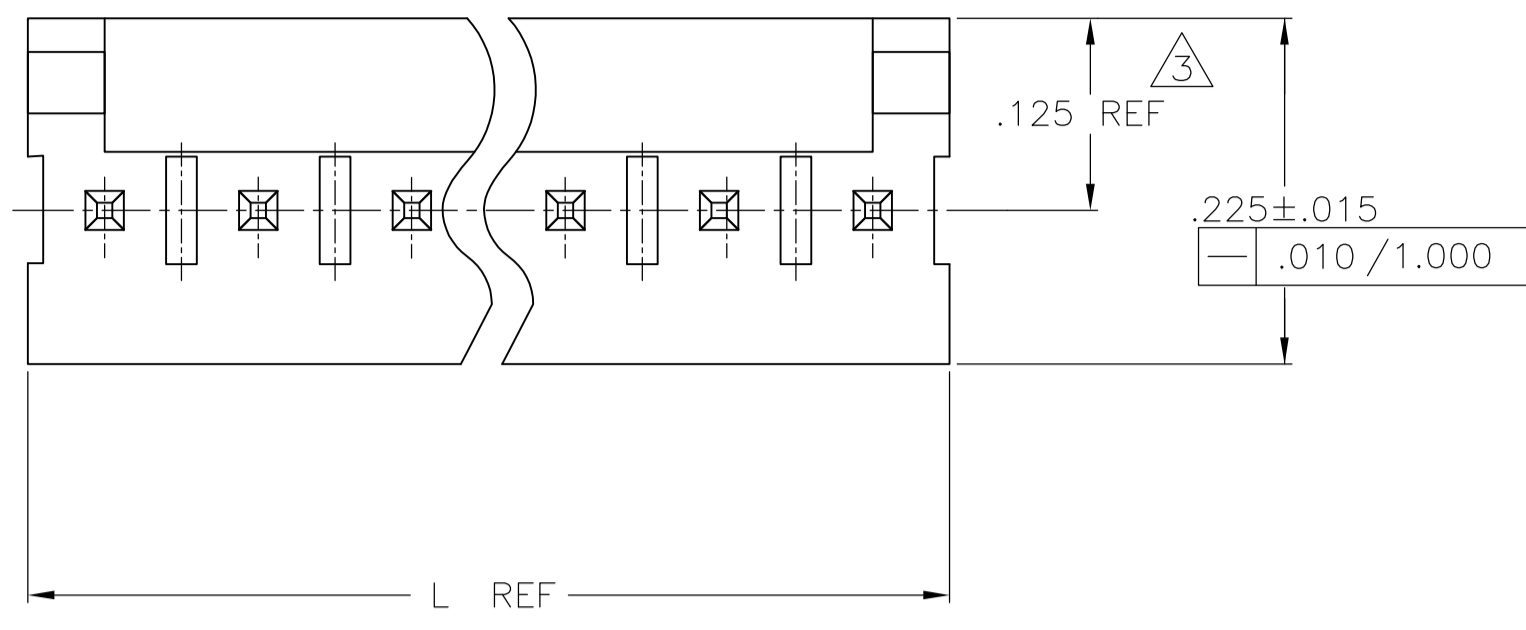
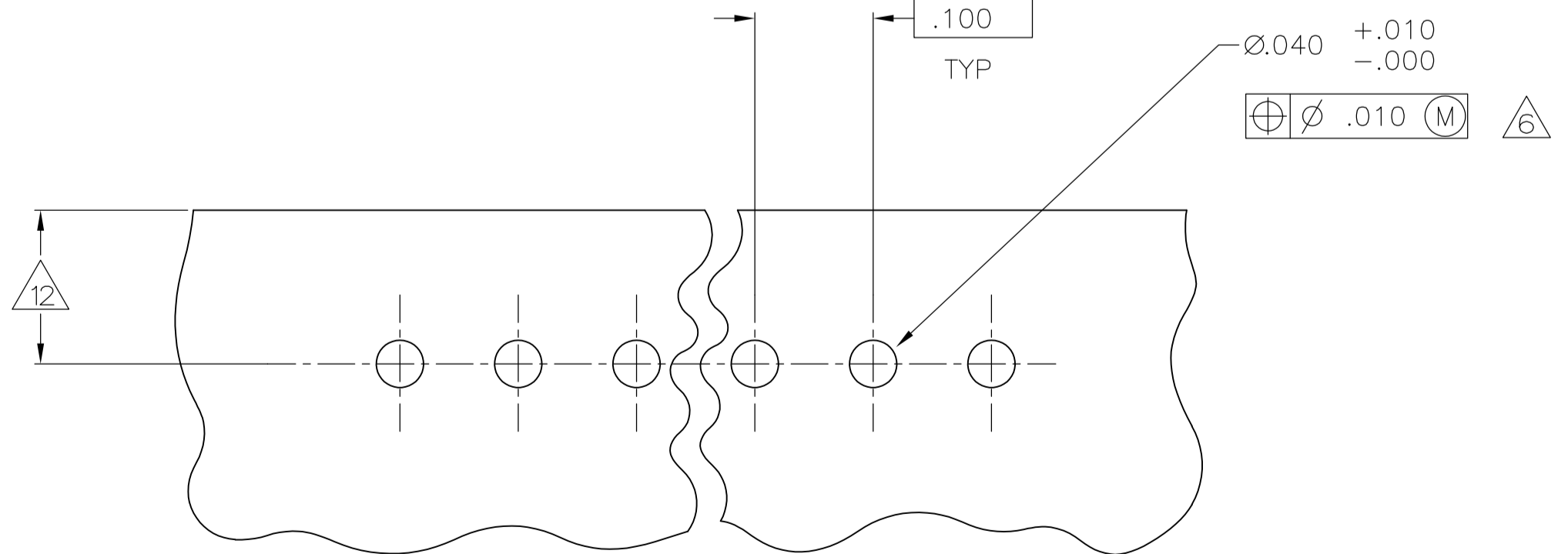

RECOMMENDED MOUNTING HOLE PATTERN FOR .063 THICK P.C. BOARD

L	IN	MM	NO OF POSITIONS	PART NUMBER
2.800	71.12	28	5-641215-8	
2.700	68.58	27	5-641215-7	
2.600	66.04	26	5-641215-6	
2.500	63.50	25	5-641215-5	
2.400	60.96	24	5-641215-4	
2.300	58.42	23	5-641215-3	
2.200	55.88	22	5-641215-2	
2.100	53.34	21	5-641215-1	
2.000	50.80	20	5-641215-0	
1.900	48.26	19	4-641215-9	
1.800	45.72	18	4-641215-8	
1.700	43.18	17	4-641215-7	
1.600	40.64	16	4-641215-6	
1.500	38.10	15	4-641215-5	
1.400	35.56	14	4-641215-4	
1.300	33.02	13	4-641215-3	
1.200	30.48	12	4-641215-2	
1.100	27.94	11	4-641215-1	
1.000	25.40	10	4-641215-0	
.900	22.86	9	3-641215-9	
.800	20.32	8	3-641215-8	
.700	17.78	7	3-641215-7	
.600	15.24	6	3-641215-6	
.500	12.70	5	3-641215-5	
.400	10.16	4	3-641215-4	
.300	7.62	3	3-641215-3	
.200	5.08	2	3-641215-2	

L	IN	MM	NO OF POSITIONS	PART NUMBER
2.800	71.12	28	2-641215-8	
2.700	68.58	27	2-641215-7	
2.600	66.04	26	2-641215-6	
2.500	63.50	25	2-641215-5	
2.400	60.96	24	2-641215-4	
2.300	58.42	23	2-641215-3	
2.200	55.88	22	2-641215-2	
2.100	53.34	21	2-641215-1	
2.000	50.80	20	2-641215-0	
1.900	48.26	19	1-641215-9	
1.800	45.72	18	1-641215-8	
1.700	43.18	17	1-641215-7	
1.600	40.64	16	1-641215-6	
1.500	38.10	15	1-641215-5	
1.400	35.56	14	1-641215-4	
1.300	33.02	13	1-641215-3	
1.200	30.48	12	1-641215-2	
1.100	27.94	11	1-641215-1	
1.000	25.40	10	1-641215-0	
.900	22.86	9	641215-9	
.800	20.32	8	641215-8	
.700	17.78	7	641215-7	
.600	15.24	6	641215-6	
.500	12.70	5	641215-5	
.400	10.16	4	641215-4	
.300	7.62	3	641215-3	
.200	5.08	2	641215-2	

THIS DRAWING IS A CONTROLLED DOCUMENT.

DIMENSIONS: INCHES	TOLERANCES UNLESS OTHERWISE SPECIFIED:	DIN K. WHITAKER 11JUN2004	APPROVED D. BOSSI 11JUN04	NAME
0.125	0.005	0.005	0.005	MTA-100 HDR ASSY, FRICTION LOCK, NOTCHED, .025 SQUARE STRAIGHT POST, .000030 GOLD PLATED
0.005	0.005	0.005	0.005	APPLICATION SPEC
0.005	0.005	0.005	0.005	SIZE
0.005	0.005	0.005	0.005	WEIGHT
0.005	0.005	0.005	0.005	CUSTOMER DRAWING

SCALE: 8:1 SHEET 1 OF 1 REV: Z4

Mouser Electronics

Authorized Distributor

Click to View Pricing, Inventory, Delivery & Lifecycle Information:

[TE Connectivity:](#)

[641215-9](#)