

PART NUMBER	REV	FIRST USED	POWER UNIT	FEED TYPE
1852137-1	A	122500-1	LEADMAKER	POST FEED
1852137-2	A	565435-5	BENCH MODEL K	PRE FEED
1852137-3	A	354500-1	BENCH MODEL G	PRE FEED

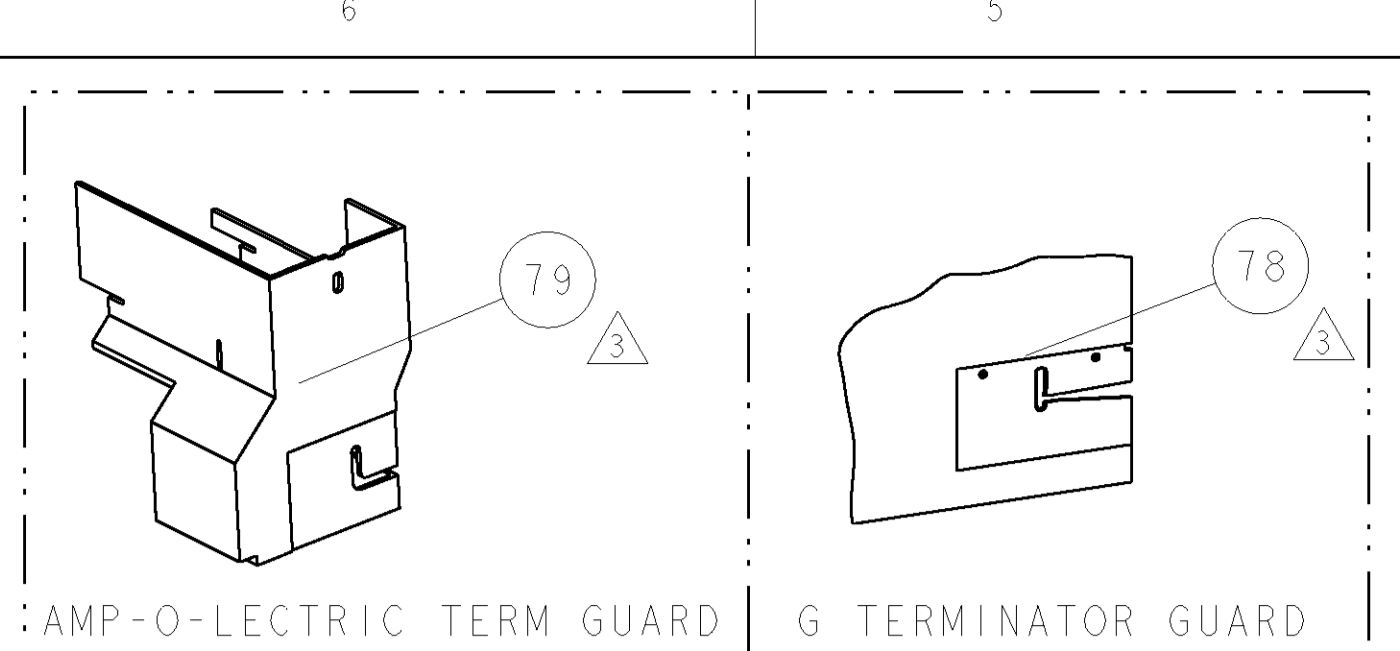

TERMINAL NAME: TERMINAL, PIN					
CUST PRT #	TYCO PRT #	SUMITOMO TERMINAL - AMP CRIMP SPECS			
8100-1572	1572814-1	PAD LTR	CRIMP HEIGHT	WIRE SIZE	
-	-	A	.064±.002[1.63±0.05mm]	14 AWG	
-	-	B	.054±.002[1.37±0.05mm]	16 AWG	
-	-	C	-	-	
-	-	D	-	-	
-	-	CRIMP	SIZE	TYPE	RANGE
-	-	-	.100 [2.54mm]	F	16-14AWG
-	-	WIRE	.120 [3.05mm]	O	∅.120 MAX
-	-	INSUL	-	-	-
WIRE STRIP LENGTH	TERM APPL SPEC	FEED	APPL INSTRUCTIONS	SET UP GAGE	
.184 -.199	NONE	.397	408-8040	458637-1	

LOC	DIST	REV	DESCRIPTION	DATE	BY	APPD
A	66		RELEASED	200205	LG	GB

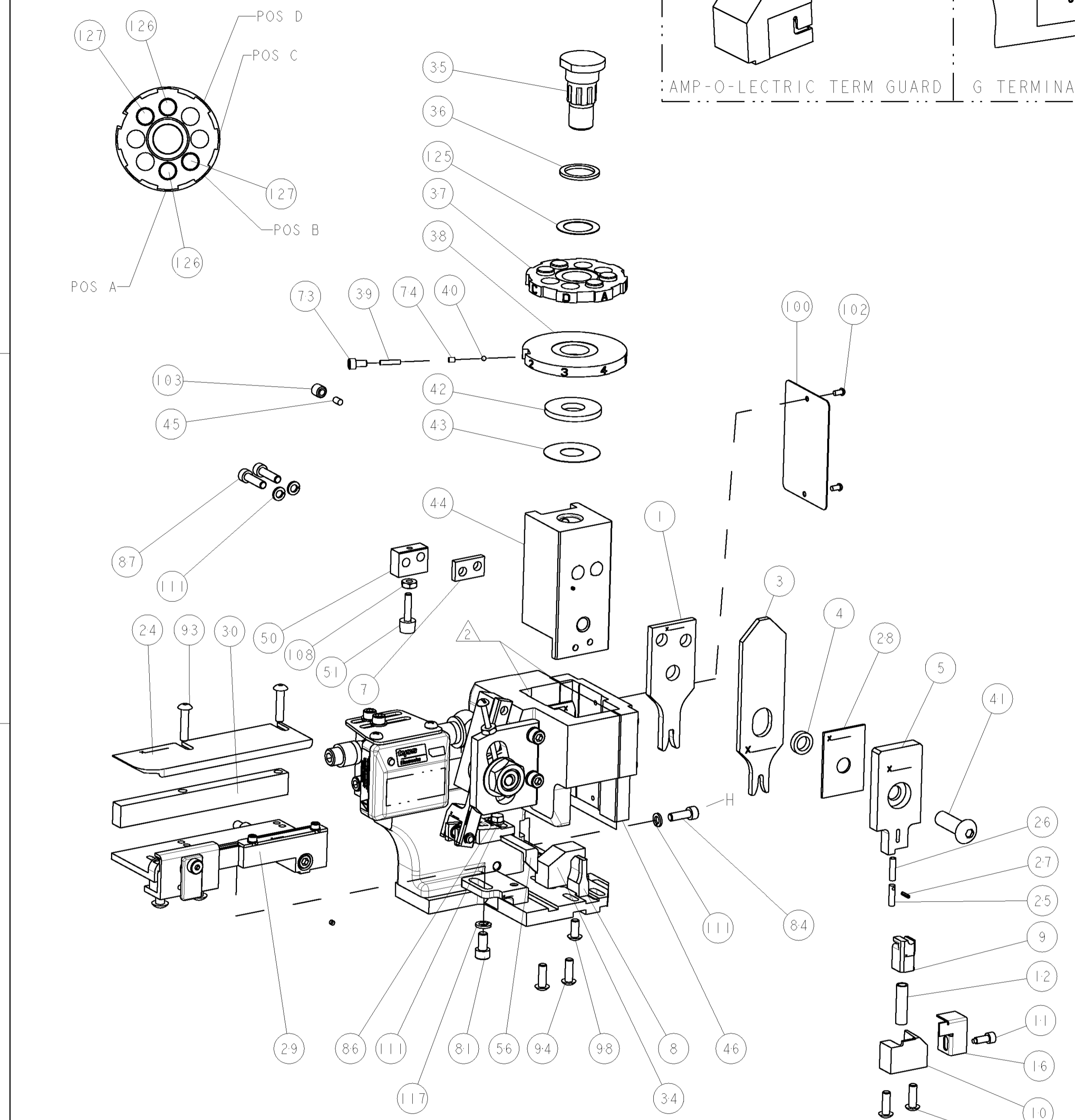

- △ RECOMMENDED SPARE PARTS
- △ GREASE LIGHTLY
- △ GUARD MUST BE IN PLACE WHEN OPERATING APPLICATOR IN A BENCH MACHINE

-	-	-	-	-	-	129
-	-	-	-	-	-	128
2	2	2	-	4-354779-1	PIN, WIRE DISC, .3195	127
2	2	2	-	1-354779-8	PIN, WIRE DISC, .3080	126
1	1	1	-	986950-1	WASHER, FLAT PRECISION	125
1	1	1	-	217238-1	GENERAL INSTRUCTION PKG	124
1	1	1	-	4088040	SF APPL INST 408-8040	123
-	-	-	-	-	-	122
-	-	-	-	-	-	121
-	-	-	-	-	-	120
-	-	-	-	-	-	119
-	-	-	-	-	-	118
1	1	1	-	21024-5	WASHER, SPRG LOCK, REG NO 10	117
-	-	-	-	-	-	116
-	-	-	-	-	-	115
-	-	-	-	-	-	114
-	-	-	-	-	-	113
-	-	-	-	-	-	112
4	4	4	-	21024-4	WASHER, SPRG LOCK, REG NO 8	111
-	-	-	-	-	-	110
-	-	-	-	-	-	109
1	1	1	-	21018-5	NUT, HEX, REG 6-32	108
-	-	-	-	-	-	107
-	-	-	-	-	-	106
-	-	-	-	-	-	105
-	-	-	-	-	-	104
1	1	1	-	21009-2	SCR, SET, SELF LOCKING 1/4-20 X .250	103
2	2	2	-	21017-2	SCREW, DRIVE	102
-	-	-	-	-	-	101
1	1	1	-	461264-1	PLATE, IDENTIFICATION	100
-	-	-	-	-	-	99
1	1	1	-	22733-8	SCR, BHSC, SELF-LOCKING, 8-32 X .375	98
-	-	-	-	-	-	97
-	-	-	-	-	-	96
-	-	-	-	-	-	95
4	4	4	-	2-21002-2	SCR, BTN SKT HD CAP 8-32 X .500	94
2	2	2	-	2-21002-4	SCR, BTN SKT HD CAP 8-32 X .750	93
-	-	-	-	-	-	92
1	1	1	-	1-21002-7	SCR, BTN SKT HD CAP 6-32 X .375	91
-	-	-	-	-	-	90
-	-	-	-	-	-	89
-	-	-	-	-	-	88
2	2	2	-	2-21000-8	SCR, SKT HD CAP 8-32 X .625	87
1	1	1	-	2-22603-0	SCR, HEX HD CAP 8-32 X .312	86
-	-	-	-	-	-	85
1	1	1	-	2-21000-7	SCR, SKT HD CAP 8-32 X .500	84
-	-	-	-	-	-	83
-	-	-	-	-	-	82
1	1	1	-	3-21000-4	SCR, SKT HD CAP 10-32 X .375	81
-	-	-	-	-	-	80
-	-	-	-	-	-	79
REF	-	-	-	455749-1	GUARD WINDOW	78
REF	-	-	-	679532-1	INSERT, GUARD	77
-	-	-	-	-	-	76
-	-	-	-	-	-	75
1	1	1	-	690603-1	SPRING ASSIST AMP-O-MATOR APPLICATOR	74
-	-	-	-	-	-	73
-3	-2	-1	U/M	PART NO	DESCRIPTION	ITEM NO

1	1	1	-	23030-1	SCR, SKT HD CAP 6-32 X .25	73
-	-	-	-	-	-	72
-	-	-	-	-	-	71
-	-	-	-	-	-	70
-	-	-	-	-	-	69
-	-	-	-	-	-	68
-	-	-	-	-	-	67
-	-	-	-	-	-	66
-	-	-	-	-	-	65
-	-	-	-	-	-	64
-	-	-	-	-	-	63
-	-	-	-	-	-	62
-	-	-	-	-	-	61
-	-	-	-	-	-	60
-	-	-	-	-	-	59
-	-	-	-	-	-	58
-	-	-	-	-	-	57
1	1	1	-	458537-2	PAWL, FEED	56
-	-	-	-	-	-	55
-	-	-	-	-	-	54
-	-	-	-	-	-	53
-	-	-	-	-	-	52
1	1	1	-	811242-2	BUMPER, HOLD DOWN	51
1	1	1	-	690753-1	SPACER, TONKER	50
1	-	-	-	690602-6	CAM, PRE FEED, 1 5/8	49
-	1	-	-	690602-5	CAM, PRE FEED, 1 1/8	48
-	-	1	-	690501-4	CAM, POST FEED, 1 5/8	47
1	1	1	-	459456-1	APPL. BASIC SUB ASSY (SIDE WISE MOCA)	46
1	1	1	-	690191-1	PLUG, NYLON	45
1	1	1	-	455673-1	RAM, SIDE FEED	44
1	1	1	-	690125-1	SHIM SUB-ASSY	43
1	1	1	-	690124-1	WASHER, RAM (.115)	42
1	1	1	-	7-21002-9	SCR, BTN SKT HD CAP 5/16-24 X 1.00	41
1	1	1	-	23241-6	BALL, STEEL	40
1	1	1	-	690170-1	SPRING, COMPRESSION	39
1	1	1	-	1-690142-2	DISC, INSULATION	38
1	1	1	-	354777-1	WIRE DISC, ASSEMBLY	37
1	1	1	-	22480-5	SPRING, COMPRESSION	36
1	1	1	-	690212-1	POST, RAM	35
1	1	1	-	690786-3	TERMINAL SUPPORT	34
-	-	-	-	-	-	33
-	-	-	-	-	-	32
-	-	-	-	-	-	31
1	1	1	-	1320908-1	SPACER, STRIP GUIDE	30
1	1	1	-	1633091-1	SUB-ASSEMBLY, FEEDTRACK	29
1	1	1	-	1-455688-0	SPACER, CRIMPER	28
1	1	1	-	21028-2	PIN, SLOTTED SPRING .062 X .250	27
1	1	1	-	1-22278-0	SPRING, COMPRESSION	26
1	1	1	-	854769-4	HOLDER, INS	25
1	1	1	-	1320928-1	PLATE, STRIP GUIDE	24
-	-	-	-	-	-	23
-	-	-	-	-	-	22
-	-	-	-	-	-	21
-	-	-	-	-	-	20
1	1	1	-	690472-2	STRIPPER	19
-	-	-	-	-	-	18
-	-	-	-	-	-	17
1	1	1	-	691353-1	STRIPPER	16
-	-	-	-	-	-	15
-	-	-	-	-	-	14
-	-	-	-	-	-	13
1	1	1	-	3-22280-3	SPRING, COMPRESSION	12
1	1	1	-	690461-1	STOP, SHEAR	11
1	1	1	-	690459-1	SHEAR HOLDER, FRONT	10
1	1	1	-	462006-1	FLOATING SHEAR, FRONT	9
1	1	1	-	2-1633117-2	ANVIL, COMBINATION	8
1	1	1	-	3-240641-0	SPACER	7
-	-	-	-	-	-	6
1	1	1	-	854772-5	DEPRESSOR, SHEAR	5
1	1	1	-	238011-2	BLOCK, CRIMPER SPACER	4
1	1	1	-	4-1583690-9	CRIMPER, INSUL O	3
-	-	-	-	-	-	2
1	1	1	-	3-456407-1	CRIMPER, WIRE PREMIUM	1

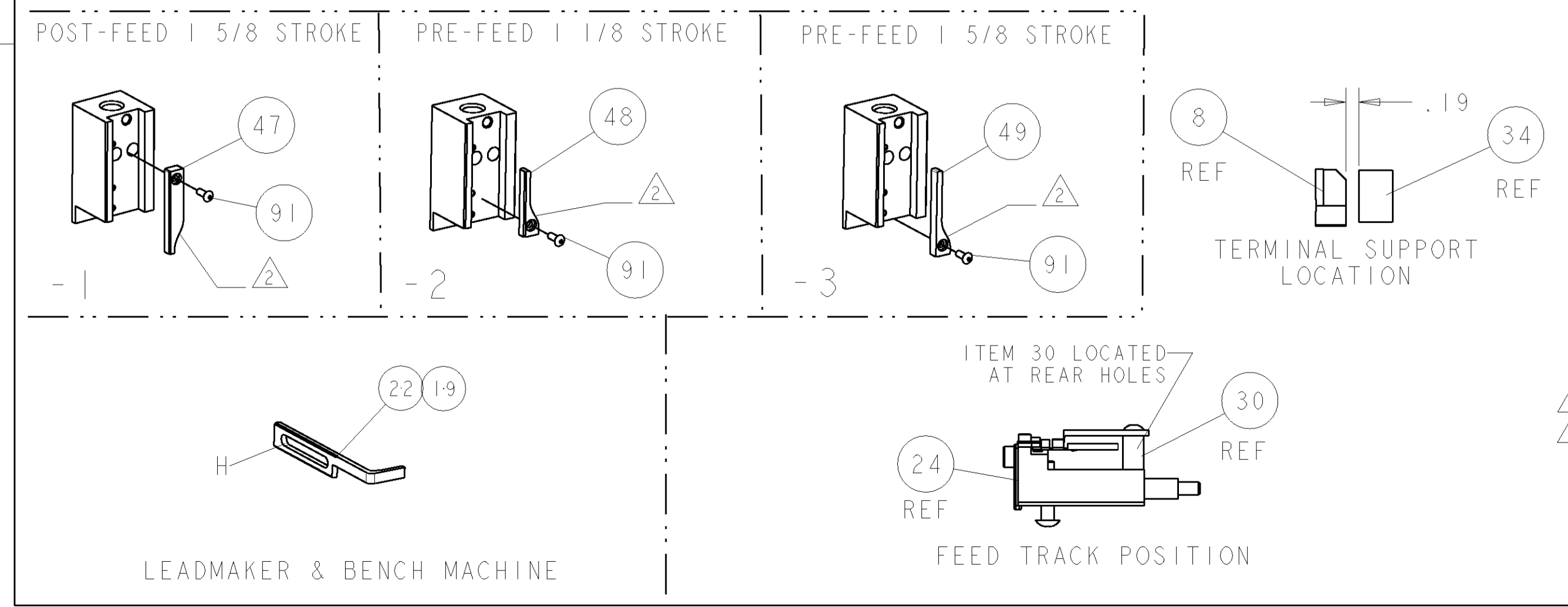

DIMENSIONS: INCHES		TOLERANCES UNLESS OTHERWISE SPECIFIED:		DWG: B. HIGMAN 23SEPT2005		Tyco Electronics Harrisburg, PA 17105-3608	
0 PLC	±	1 PLC	±0.1	2 PLC	±0.01	3 PLC	±0.001
4 PLC	±0.001	ANGLES ±0.001		APPRO: J. ELBIN 23SEPT2005		NAME: SIDE FEED HDM APPLICATOR	
MATERIAL: -		FINISH: -		WEIGHT: -		RESTRICTED TO: -	
CUSTOMER DRAWING		SCALE: 3:5		SHEET: 1 OF 1		REV: A	

Mouser Electronics

Authorized Distributor

Click to View Pricing, Inventory, Delivery & Lifecycle Information:

[TE Connectivity:](#)

[1852137-3](#)