

- 1 0.00076 [.000030] GOLD IN LOCALIZED PLATE AREA 0.00381 [.000150] TIN-LEAD ON SOLDER LEADS ALL OVER 0.00127 [.000050] NICKEL
- 2 USE 1.32±0.02 [.0520±.0010] DRILLED HOLE (#55 DRILL) FINISH TO BE TIN-LEAD OVER 0.02 [.001] MIN COPPER
- 3 PLATING: 0.0038 [.000150] TIN-LEAD OVER 0.00127 [.000050] NICKEL
- 4 SERRATIONS OPTIONAL THIS SURFACE.
- 5 0.00076 [.000030] GOLD IN LOCALIZED PLATE AREA 0.00381 [.000150] TIN ON SOLDER LEADS ALL OVER 0.00127 [.000050] NICKEL
- 6 PRELIMINARY PART - NOT RELEASED FOR PRODUCTION.
- 7 PLATING: 0.0038 (.00015) TIN OVER .00127 (.000050) NICKEL.
- 8 USE 1.32+/-0.02 (.052+/-0.0010) DRILLED HOLE (#55 DRILL) FINISH TO BE TIN OVER 0.02 (.001) MIN COPPER
- 9 ROHS 2002/95/EC COMPLIANT.
- 10 OBSOLETE PARTS: OBSOLETE CIS STREAMLINING PER D.RENAUD/D.SINISI

FINISH	NO. OF SPA (SEE DETAIL R)	D	C	B	A	NUMBER OF POSITIONS	PART NUMBER		
9	5	7	49	71.12 [2.800]	62.87 [2.475]	99	73.15 [2.880]	100	6-104894-0
9	5	7	44	64.77 [2.550]	56.52 [2.225]	89	66.80 [2.630]	90	5-104894-9
9	5	7	39	58.42 [2.300]	50.17 [1.975]	79	60.45 [2.380]	80	5-104894-8
9	5	7	34	52.07 [2.050]	43.82 [1.725]	69	54.10 [2.130]	70	5-104894-7
9	5	7	29	45.72 [1.800]	37.47 [1.475]	59	47.75 [1.880]	60	5-104894-6
9	5	7	24	39.37 [1.550]	31.12 [1.225]	49	41.40 [1.630]	50	5-104894-5
9	5	7	19	33.02 [1.300]	24.77 [0.975]	39	35.05 [1.380]	40	5-104894-4
9	5	7	14	26.67 [1.050]	18.42 [0.725]	29	28.70 [1.130]	30	5-104894-3
9	5	7	9	20.32 [0.800]	12.07 [0.475]	19	22.35 [0.880]	20	5-104894-2
9	5	7	4	13.97 [0.550]	5.72 [0.225]	9	16.00 [0.630]	10	5-104894-1
6	5	7	24	39.37 [1.550]	31.12 [1.225]	49	41.40 [1.630]	50	1-104894-5
6	5	7	14	26.67 [1.050]	18.42 [0.725]	29	28.70 [1.130]	30	1-104894-3
1	3		49	71.12 [2.800]	62.87 [2.475]	99	73.15 [2.880]	100	1-104894-0
1	3		44	64.77 [2.550]	56.52 [2.225]	89	66.80 [2.630]	90	104894-9
1	3		39	58.42 [2.300]	50.17 [1.975]	79	60.45 [2.380]	80	104894-8
1	3		34	52.07 [2.050]	43.82 [1.725]	69	54.10 [2.130]	70	104894-7
1	3		29	45.72 [1.800]	37.47 [1.475]	59	47.75 [1.880]	60	104894-6
1	3		24	39.37 [1.550]	31.12 [1.225]	49	41.40 [1.630]	50	104894-5
1	3		19	33.02 [1.300]	24.77 [0.975]	39	35.05 [1.380]	40	104894-4
1	3		14	26.67 [1.050]	18.42 [0.725]	29	28.70 [1.130]	30	104894-3
1	3		9	20.32 [0.800]	12.07 [0.475]	19	22.35 [0.880]	20	104894-2
1	3		4	13.97 [0.550]	5.72 [0.225]	9	16.00 [0.630]	10	104894-1

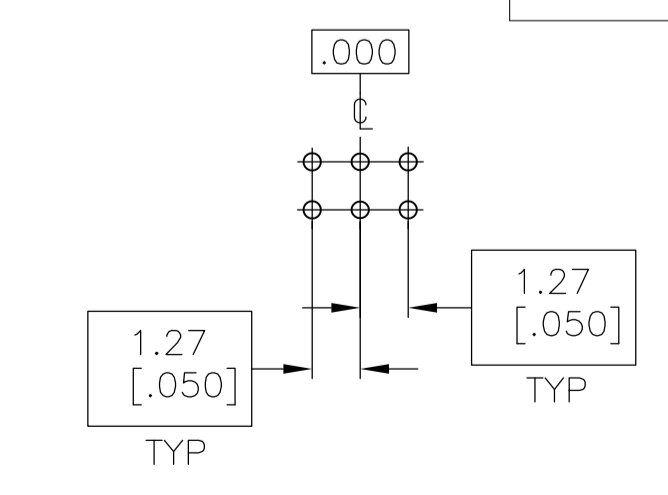
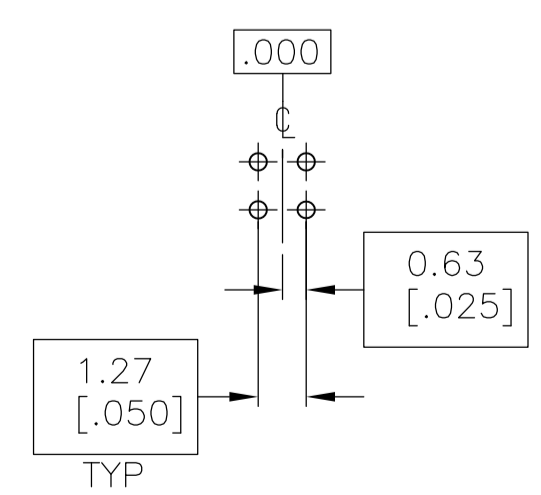
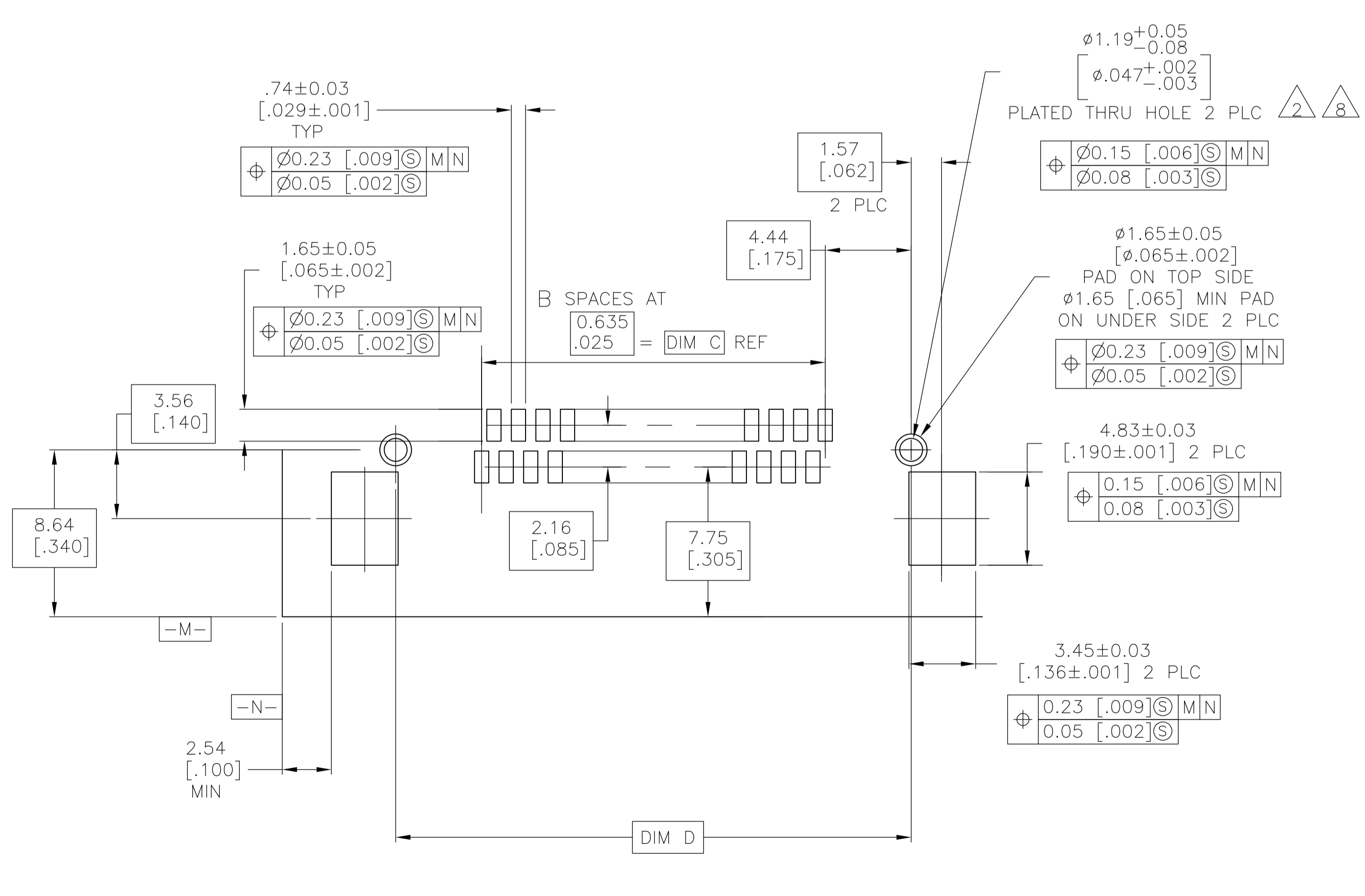

RECOMMENDED BOARD LAYOUT  
SCALE 5:1

BASIC DIMENSIONS FOR ODD NO OF SPACES (SEE TABLE)

DETAIL R

BASIC DIMENSIONS FOR EVEN NO OF SPACES (SEE TABLE)

THIS DRAWING IS A CONTROLLED DOCUMENT.

DIMENSIONS: mm (INCHES)	TOLERANCES UNLESS OTHERWISE SPECIFIED:	APVD: D. DUPLER	NAME: ASSEMBLY, HEADER, RIGHT ANGLE, DOUBLE ROW, AMPMODU 50/50 GRID CONNECTOR
0 PLC ± -	1 PLC ± 0.13[.005]	PRODUCT SPEC: 108-1332	APPLICATION SPEC: 114-7010
2 PLC ± -	3 PLC ± -	SIZE: A1	SCALE: 5:1
4 PLC ± -	ANGLES ± -	WEIGHT: -	SHEET 1 of 1
MATERIAL: LCP, COLOR BLACK	CONTACT: BRASS	FINISH: SEE TABLE	RESTRICTED TO: -
HOLDDOWN: COPPER ALLOY		CUSTOMER DRAWING	REV J4

STE TE Connectivity

# Mouser Electronics

Authorized Distributor

Click to View Pricing, Inventory, Delivery & Lifecycle Information:

[TE Connectivity:](#)

[5-104894-6](#)