

INTERLOCK P/N	FCI P/N	GRIP CODE	WIRE SIZE	CONDUCTOR CH (SECT Z-Z, ±0.05)	CONDUCTOR CW (SECT Z-Z, ±0.10)	INSULATION CH (SECT Y-Y, ±0.10)	INSULATION CW (SECT Y-Y, ±0.10)	INSULATION GRIP TYPE	PLATING OPTION	CABLE SEALED	GREASED/LUBRICANT	SERRATIONS TYPE NOS.	GRIP CODE
JTP/JS-1011-29	54001000	10	10	2.25	3.45	3.45	4.15	1	1	NO	N/A	1	2
JTP/JS-1011-29G	54001002	10	10	2.25	3.45	3.65	4.2	1	1	NO	NYE 760G U/V	1	2
JTP/JS-1011-66AU	54001003	10AU	10	2.25	3.45	3.45	4.15	1	2	NO	N/A	1	2
JTP/JS-1011-66AUG	54001025	10AU	10	2.25	3.45	3.65	4.2	1	2	NO	NYE UNIFLOR 8917	1	2
JTC/JSC-1011-29	54001008	10	10	2.25	3.45	T.B.D.	T.B.D.	3	1	YES	N/A	1	2
JTC/JSC-1011-29G	54001009	10	10	2.25	3.45	T.B.D.	T.B.D.	3	1	YES	NYE 760G U/V	1	2
JTC/JSC-1011-66AU	54001010	10AU	10	2.25	3.45	T.B.D.	T.B.D.	3	2	YES	N/A	1	2
JTP/JS-1211-29	54001208	12	12	1.95	3.45	T.B.D.	T.B.D.	1	1	NO	N/A	1	2
JTP/JS-1211-29G	54001209	12	12	1.95	3.45	T.B.D.	T.B.D.	1	2	NO	NYE 760G U/V	1	2
JTP/JS-1211-66AU	54001210	12AU	12	1.95	3.45	T.B.D.	T.B.D.	1	2	NO	N/A	1	2
JTP/JS-1211-66AUG	54001228	12AU	12	1.95	3.45	T.B.D.	T.B.D.	1	2	NO	NYE UNIFLOR 8917	1	2
JTC/JSC-1211-29	54001202	12	12	1.95	3.45	4.5	4.35	3	1	YES	N/A	1	2
JTC/JSC-1211-29G	54001205	12	12	1.95	3.45	4.5	4.35	3	1	YES	NYE 760G U/V	1	2
JTC/JSC-1211-66AU	54001206	12AU	12	1.95	3.45	4.5	4.35	3	2	YES	N/A	1	2
JTP/JS-1311-29	54001300	13	VARIOUS	VARIOUS	VARIOUS	VARIOUS	VARIOUS	2	1	NO	N/A	2	9
JTP/JS-1311-29G	54001302	13	VARIOUS	VARIOUS	VARIOUS	VARIOUS	VARIOUS	2	1	NO	NYE 760G U/V	2	9
JTP/JS-1311-66AU	54001303	13AU	VARIOUS	VARIOUS	VARIOUS	VARIOUS	VARIOUS	2	2	NO	N/A	2	9
JTP/JS-1411-29	54001400	14	14	1.6	2.45	2.72	3.2	1	1	NO	N/A	2	9
JTP/JS-1411-29G	54001402	14	14	1.6	2.45	2.72	3.2	1	1	NO	NYE 760G U/V	2	9
JTP/JS-1411-66AU	54001403	14AU	14	1.6	2.45	2.72	3.2	1	2	NO	N/A	2	9
JTP/JS-1411-66AUG	54001444	14AU	14	1.6	2.45	2.72	3.2	1	2	NO	NYE UNIFLOR 8917	2	9
JTC/JSC-1411-29	54001404	14	14	1.6	2.45	4.12	4.1	3	1	YES	N/A	2	9
JTC/JSC-1411-29G	54001409	14	14	1.6	2.45	4.12	4.1	3	1	YES	NYE 760G U/V	2	9
JTC/JSC-1411-66AU	54001410	14AU	14	1.6	2.45	4.12	4.1	3	2	YES	N/A	2	9
JTP/JS-1811-29	54001800	18	18	1.35	2.05	2.35	2.6	1	1	NO	N/A	2	7
JTP/JS-1811-29G	54001802	18	18	1.35	2.05	2.35	2.6	1	1	NO	NYE 760G U/V	2	7
JTP/JS-1811-66AU	54001803	18AU	18	1.35	2.05	2.35	2.6	1	2	NO	N/A	2	7
JTP/JS-1811-66AUG	54001875	18AU	18	1.35	2.05	2.35	2.6	1	2	NO	NYE UNIFLOR 8917	2	7
JTC/JSC-1811-29	54001807	18	18	1.35	2.05	2.35	2.6	3	1	YES	N/A	2	7
JTC/JSC-1811-29G	54001810	18	18	1.35	2.05	2.35	2.6	3	1	YES	NYE 760G U/V	2	7
JTC/JSC-1811-66AU	54001811	18AU	18	1.35	2.05	2.35	2.6	3	2	YES	N/A	2	7
JTP/JS-2211-29	54002200	22	22	1.1	1.85	1.75	2.6	1	1	NO	N/A	2	5
JTP/JS-2211-29G	54002202	22	22	1.1	1.85	1.75	2.6	1	1	NO	NYE 760G U/V	2	5
JTP/JS-2211-66AU	54002203	22AU	22	1.1	1.85	1.75	2.6	1	2	NO	N/A	2	5
JTP/JS-2211-66AUG	54002262	22AU	22	1.1	1.85	1.75	2.6	1	2	NO	NYE UNIFLOR 8917	2	5
JTC/JSC-2211-29	54002208	22	22	1.1	1.85	T.B.D.	T.B.D.	3	1	YES	N/A	2	5
JTC/JSC-2211-29G	54002209	22	22	1.1	1.85	T.B.D.	T.B.D.	3	1	YES	NYE 760G U/V	2	5
JTC/JSC-2211-66AU	54002210	22AU	22	1.1	1.85	T.B.D.	T.B.D.	3	2	YES	N/A	2	5

TABLE 1 - TERMINAL CRIMP DIMENSION (FOR REFERENCE ONLY)

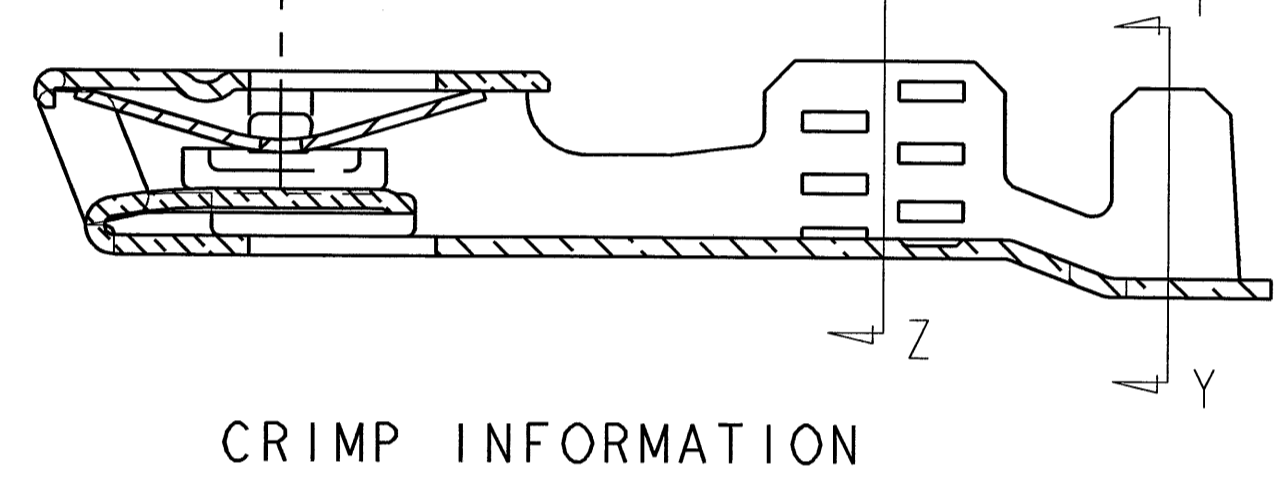

CRIMP INFORMATION

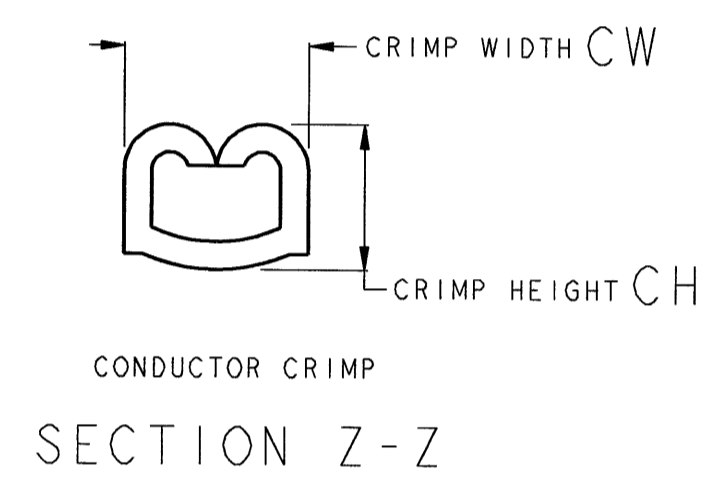

SECTION Z-Z

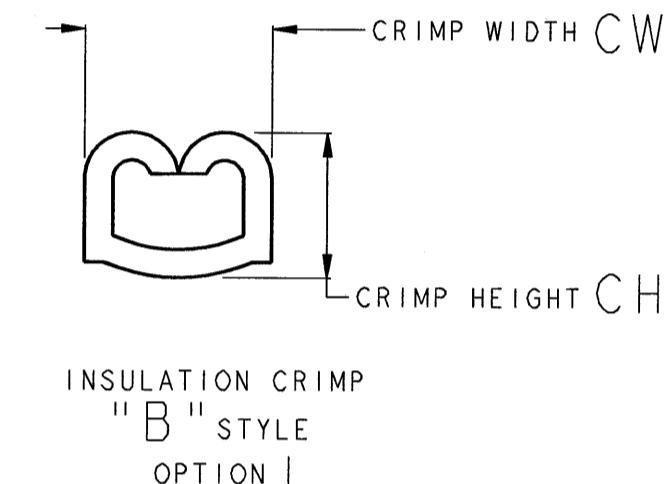

SECTION Y-Y

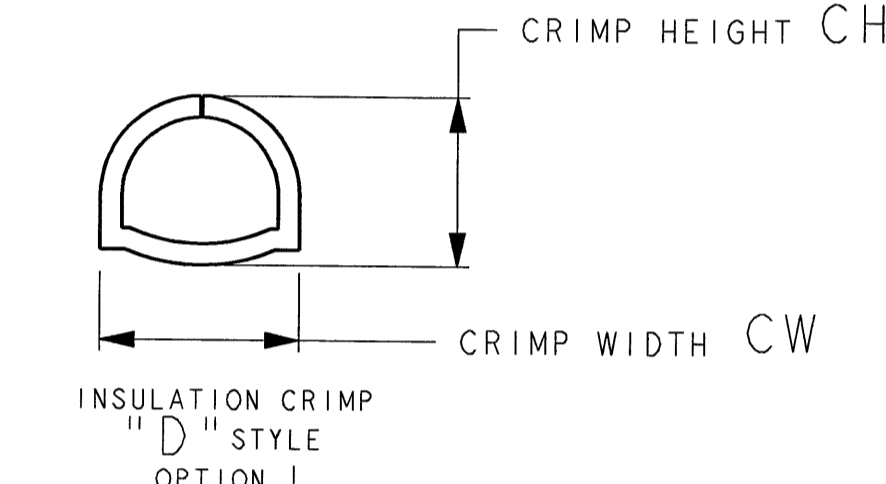

SECTION Y-Y

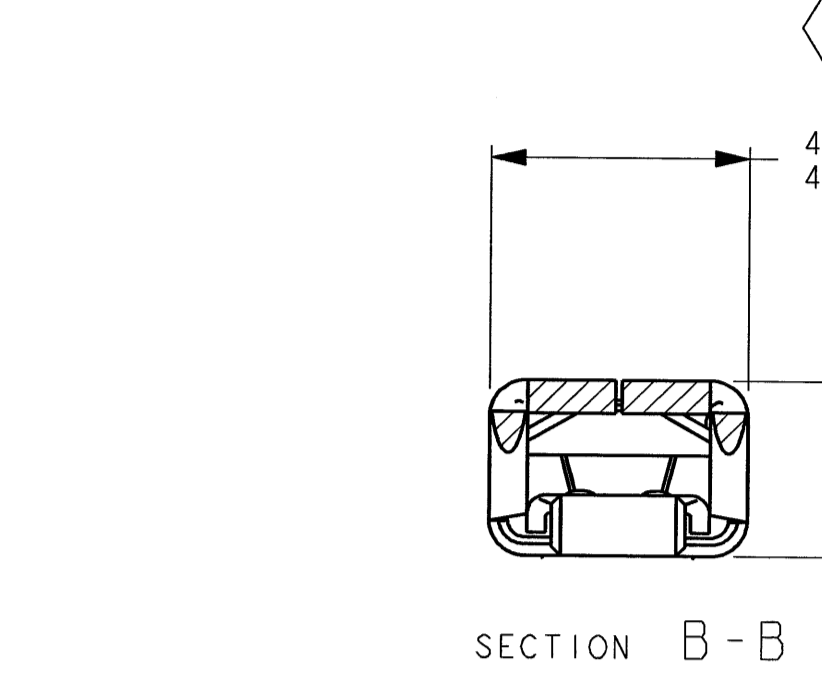

SECTION B-B

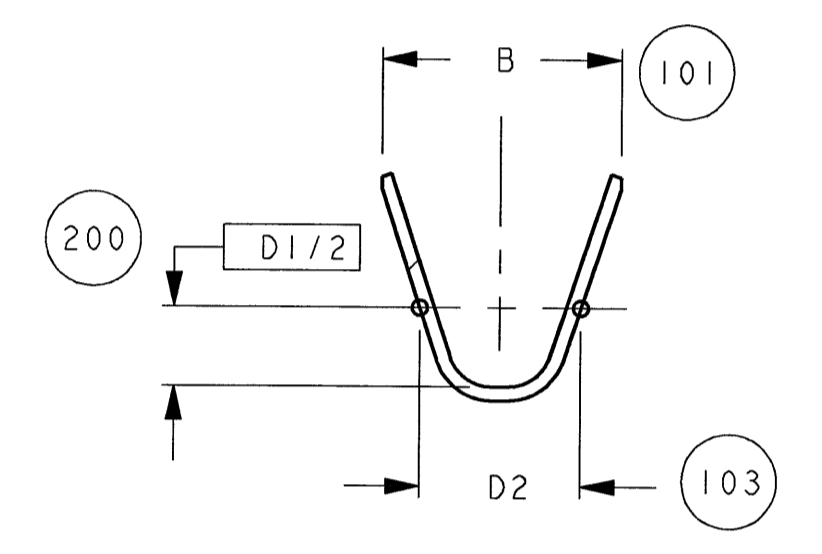

SECTION D-D UNSEALED GRIP INSULATION TYPE 1

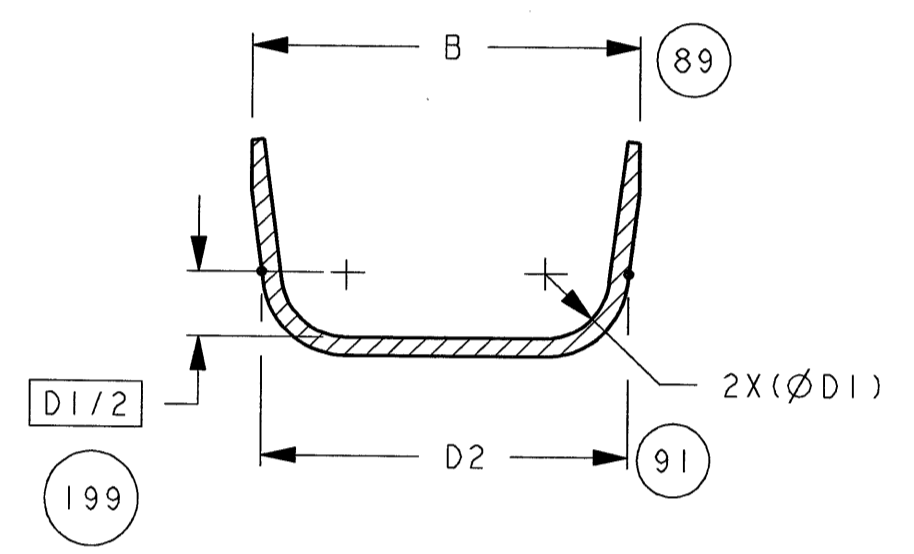

SECTION D-D DOUBLE WIRE GRIP INSULATION TYPE 2

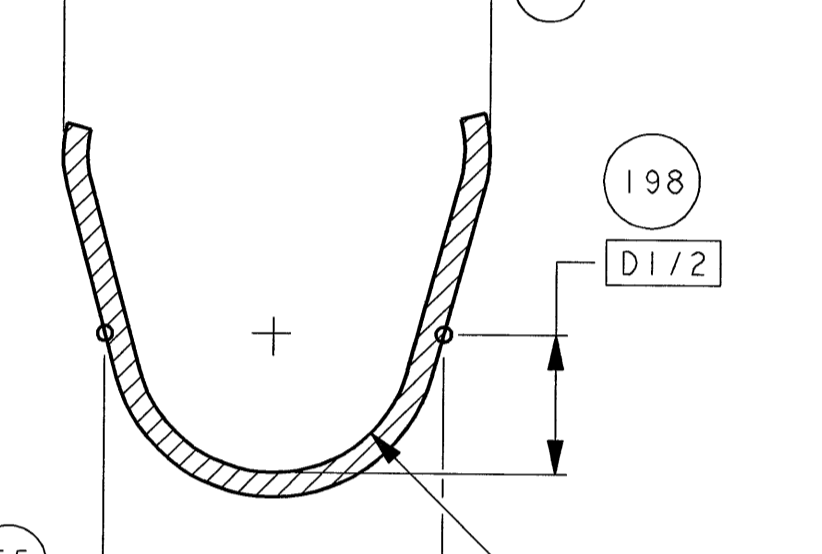

SECTION D-D CABLE SEAL GRIP INSULATION TYPE 3

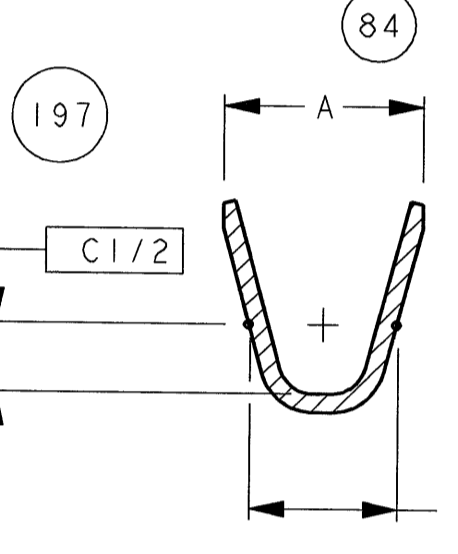

SECTION C-C CORE GRIP

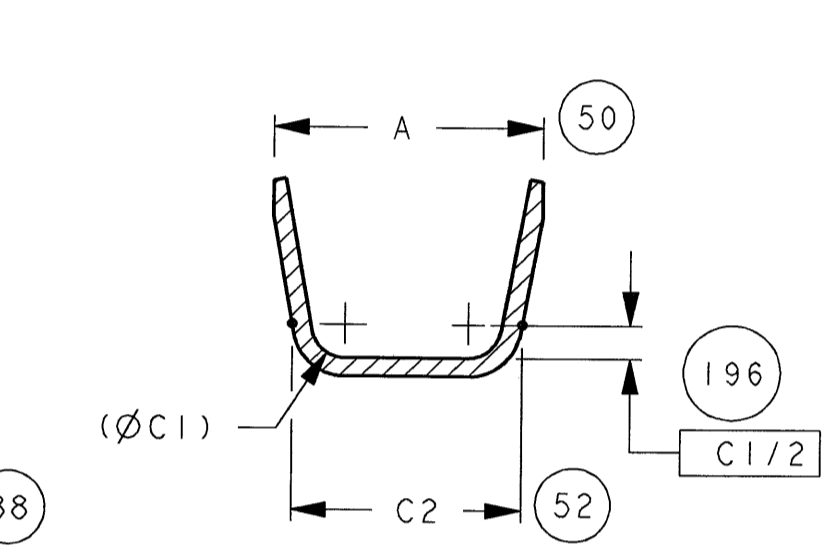

SECTION C-C DOUBLE CORE GRIP

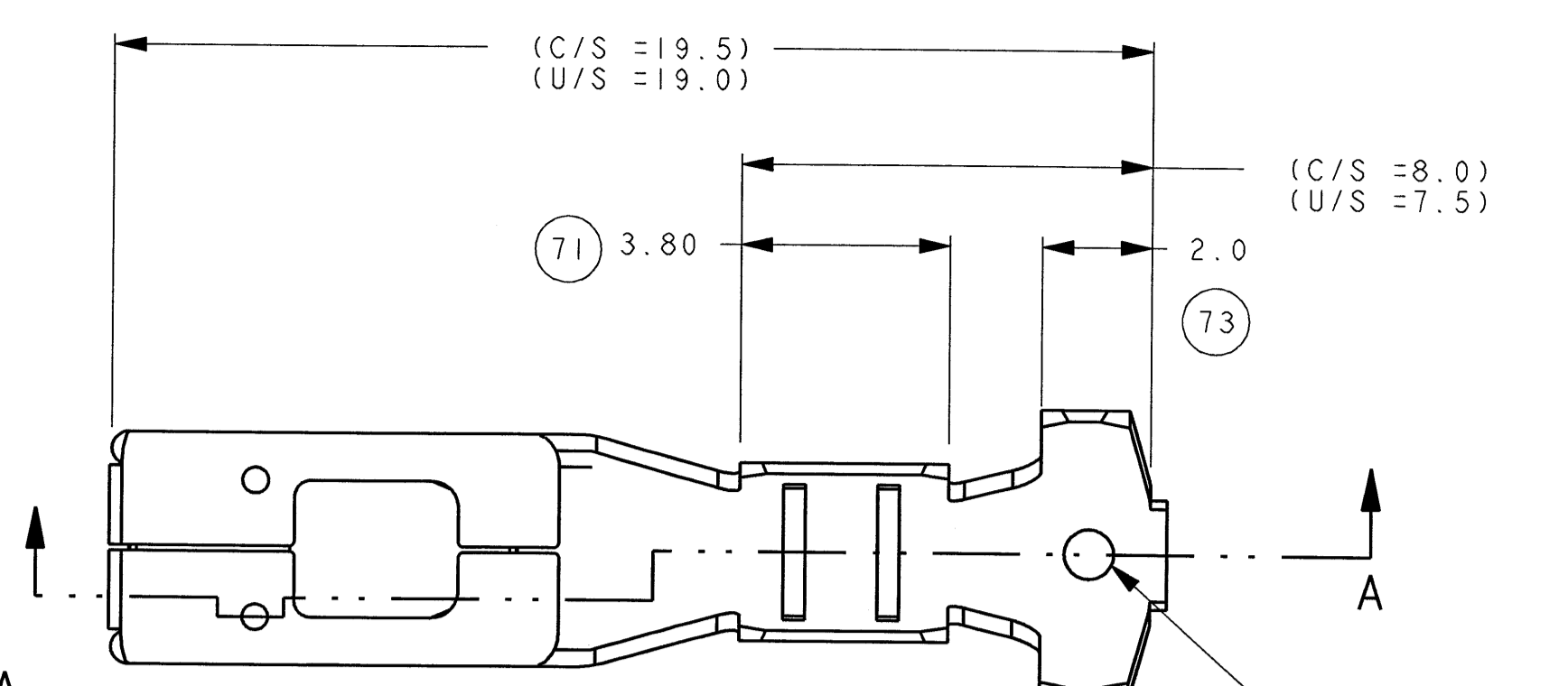

INSULATION HOLE SIZE AND SHAPE OPTIONAL FOR ALL CABLE SEAL GRIP SIZES & TYPES. NOTE: NO HOLE ON NON-CABLE SEAL APPLICATION.

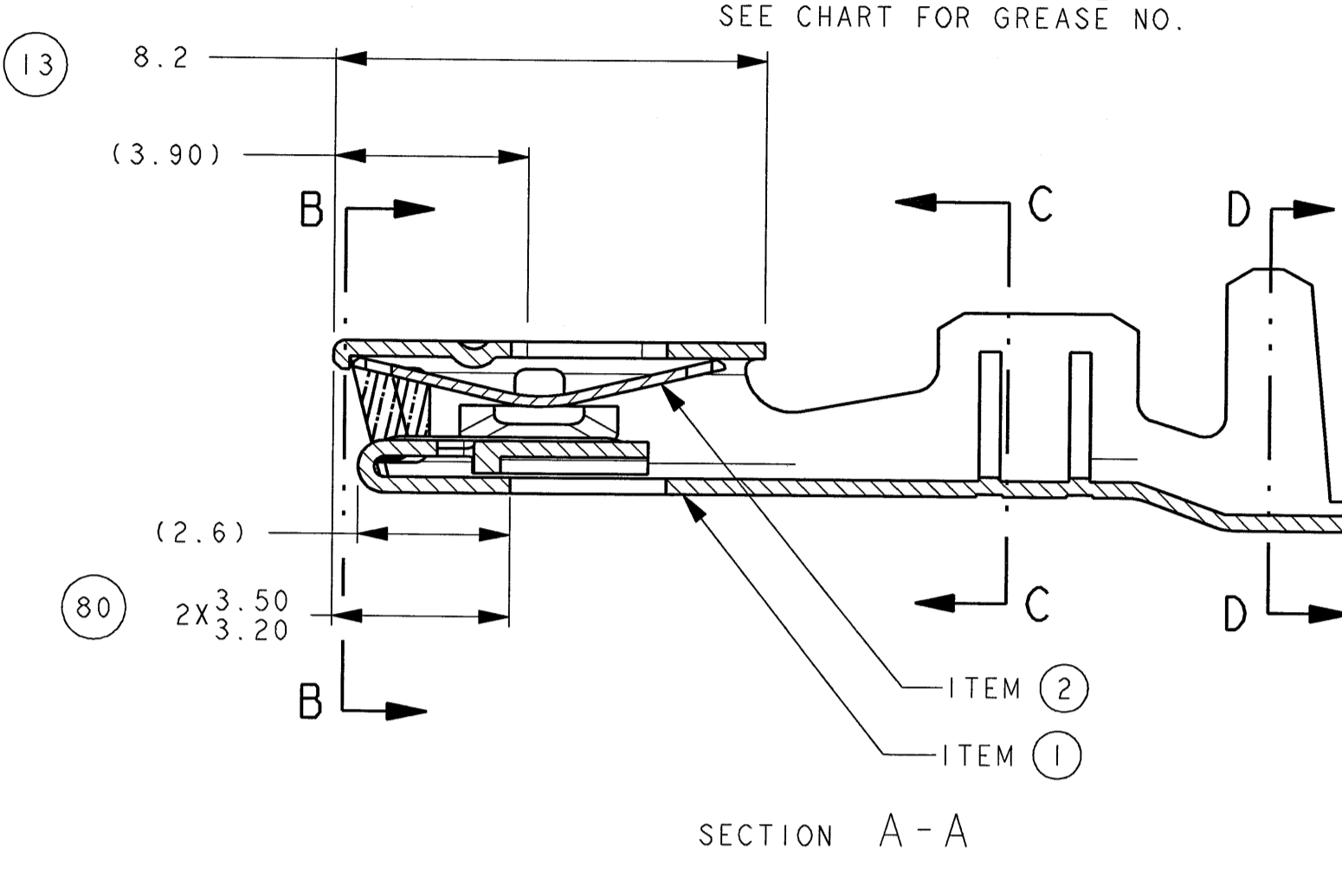

SECTION A-A

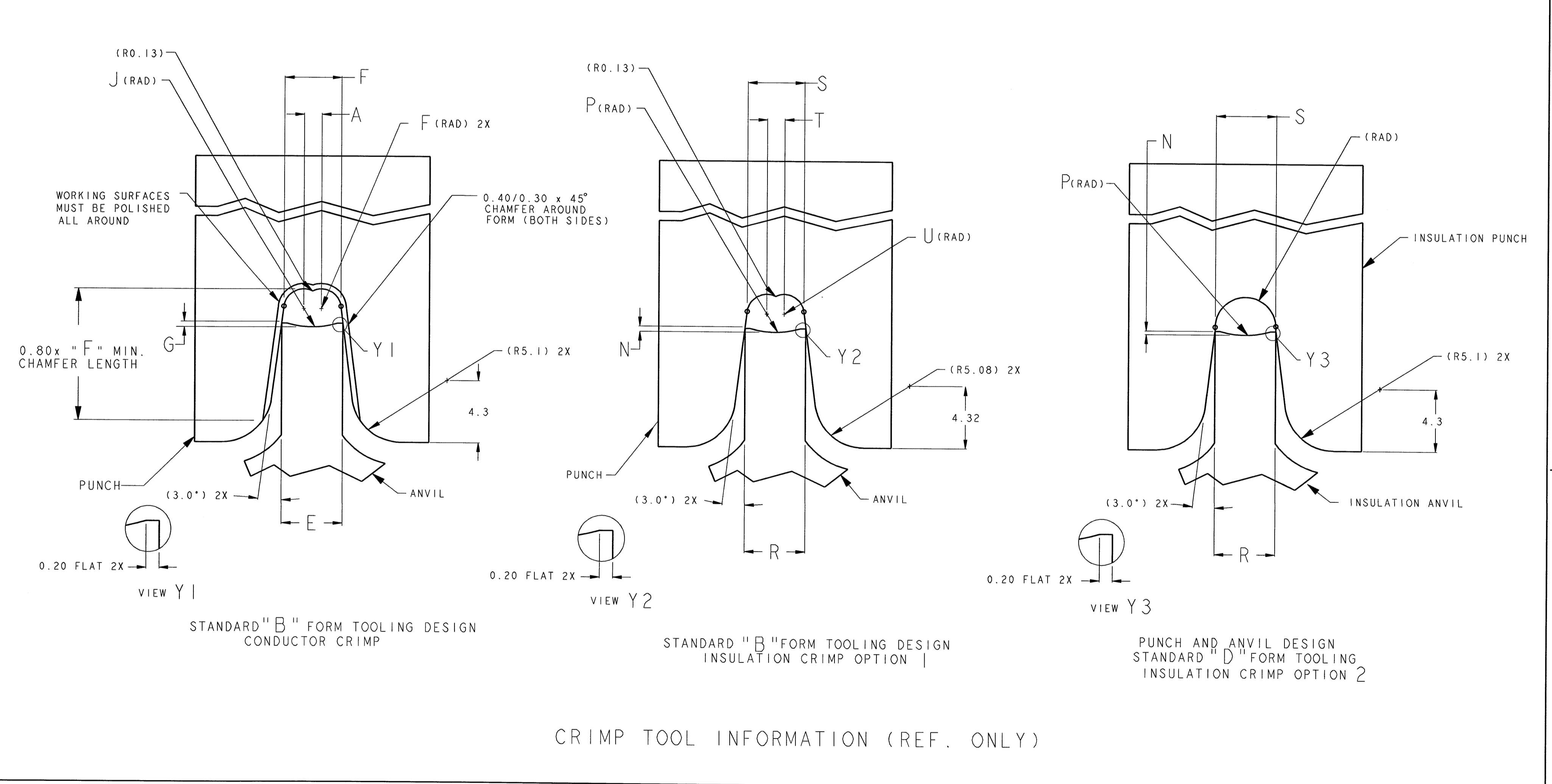

CRIMP TOOL INFORMATION (REF. ONLY)

GRIP CODE	CABLE SEALED	WIRE SPECIFICATION	A±0.30	B±0.30	(C)	C2±0.30	(D1)	D2±0.30	E±0.005	F±0.005	G±0.005	H±0.005	K±0.005	M±0.005	N±0.005	P±0.005	S±0.005	T±0.005	U±0.005	
10	NO	ESB-MIL123-A/MS 8288	5.2	6.5	2.30	3.2	3.20	4.00	1.54	0.89	0.26	4.31	3.35	3.32	0.33	5.25	4.08	4.04	2.52	1.87
10	YES	ESB-MIL123-A/MS 8288	T.B.D.	T.B.D.	T.B.D.	T.B.D.	T.B.D.	T.B.D.	T.B.D.	T.B.D.	T.B.D.	T.B.D.	T.B.D.	T.B.D.	T.B.D.	T.B.D.	T.B.D.	T.B.D.	T.B.D.	T.B.D.
12	NO	ESB-MIL123-A/MS 8288	5.2	5.2	2.30	3.2	3.00	3.80	T.B.D.	T.B.D.	T.B.D.	T.B.D.	T.B.D.	T.B.D.	T.B.D.	T.B.D.	T.B.D.	T.B.D.	T.B.D.	T.B.D.
12	YES	ESB-MIL123-A/MS 8288	5.2	6.6	2.30	3.2	4.30	5.20	1.54	0.89	0.26	4.31	3.35	3.32	0.34	5.44	4.20	4.10	N/A	N/A
13	NO	ESB-MIL123-A/MS 8288	4.6	6.6	1.50	3.7	2.55	6.00	1.92	1.11	0.34	5.38	4.17	4.13	0.34	5.36	4.17	4.13	2.58	1.92
14	NO	ESB-MIL123-A/MS 8288	3.8	4.7	1.45	2.3	2.25	3.20	1.09	0.63	1.16	3.06	2.38	2.36	0.24	4.00	3.11	3.08	N/A	N/A
14	YES	ESB-MIL123-A/MS 8288	3.8	6.1	1.45	2.3	3.80	4.60	1.09	0.63	1.16	3.06	2.38	2.36	0.32	5.13	3.96	3.94	N/A	N/A
18	NO	ESB-MIL123-A/MS 8288	3.0	3.8	1.00	1.9	1.75	2.70	0.92	0.53	0.13	2.56	1.99	1.97	0.18	3.25	2.53	2.50	N/A	N/A
18	YES	ESB-MIL123-A/MS 8288	3.0	5.1	1.00	1.9	3.00	3.70	0.92	0.53	0.13	2.56	1.99	1.97	0.24	4.13	3.18	3.17	N/A	N/A
22	NO	ESB-MIL123-A/MS 8288	2.6	3.2	0.76	1.7	1.40	2.10	0.83	0.48	0.11	2.31	1.79	1.78	0.18	3.25	2.53	2.50	N/A	N/A
22	YES	ESB-MIL123-A/MS 8288	T.B.D.	T.B.D.	T.B.D.	T.B.D.	T.B.D.	T.B.D.	T.B.D.	T.B.D.	T.B.D.	T.B.D.	T.B.D.	T.B.D.	T.B.D.	T.B.D.	T.B.D.	T.B.D.	T.B.D.	T.B.D.

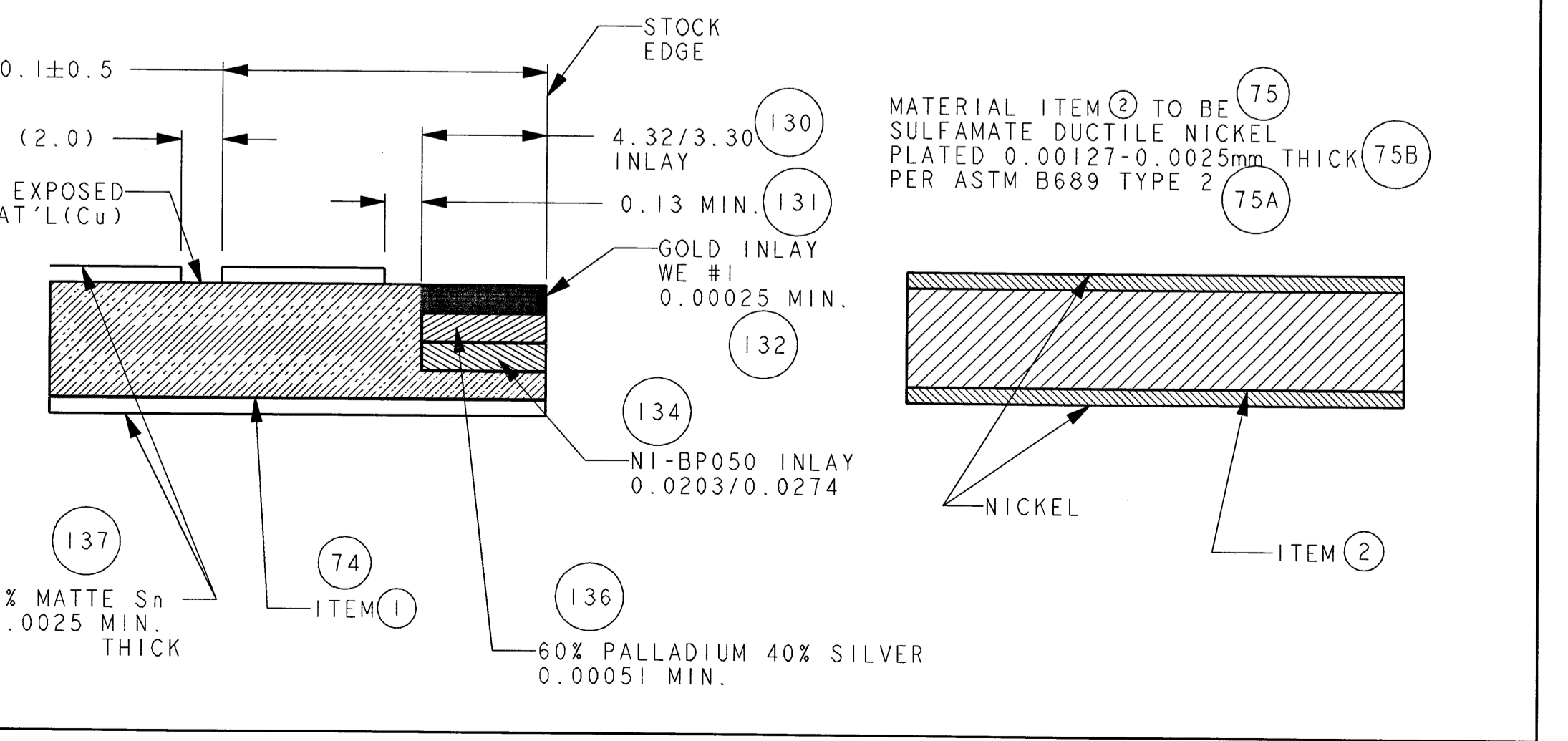
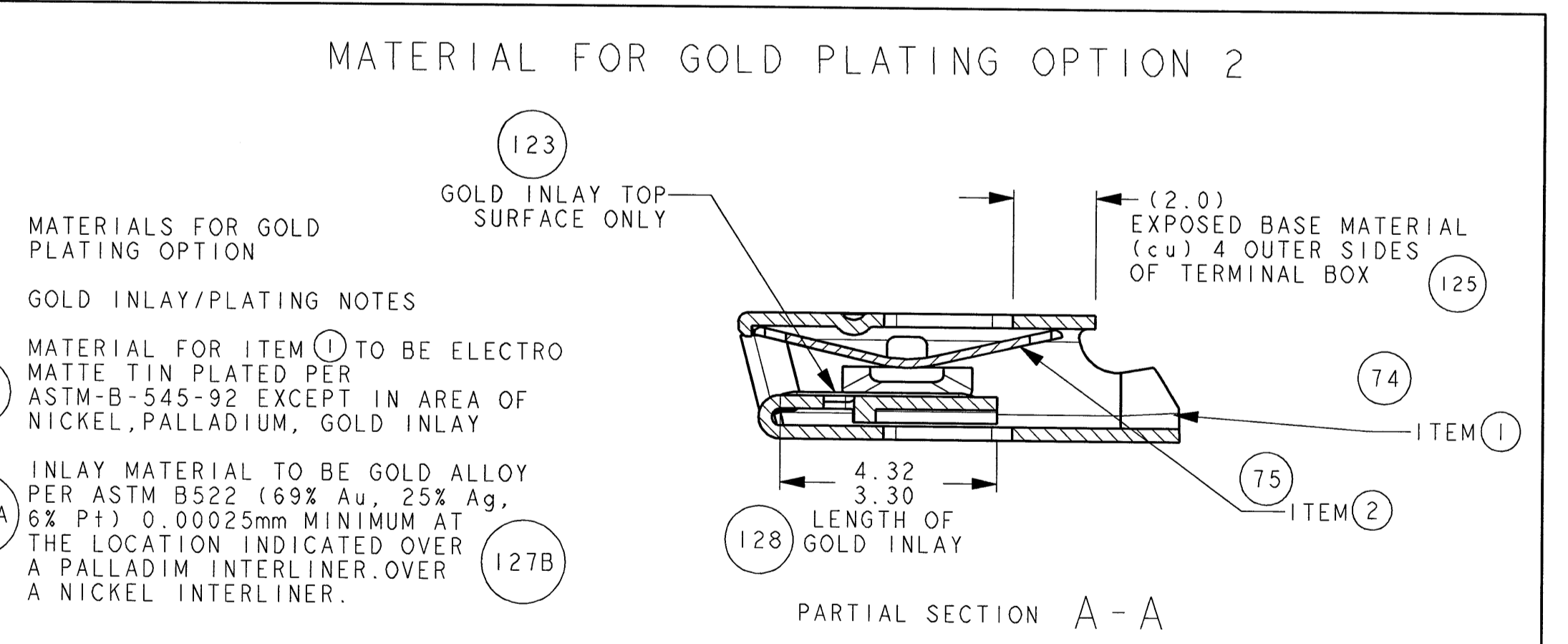
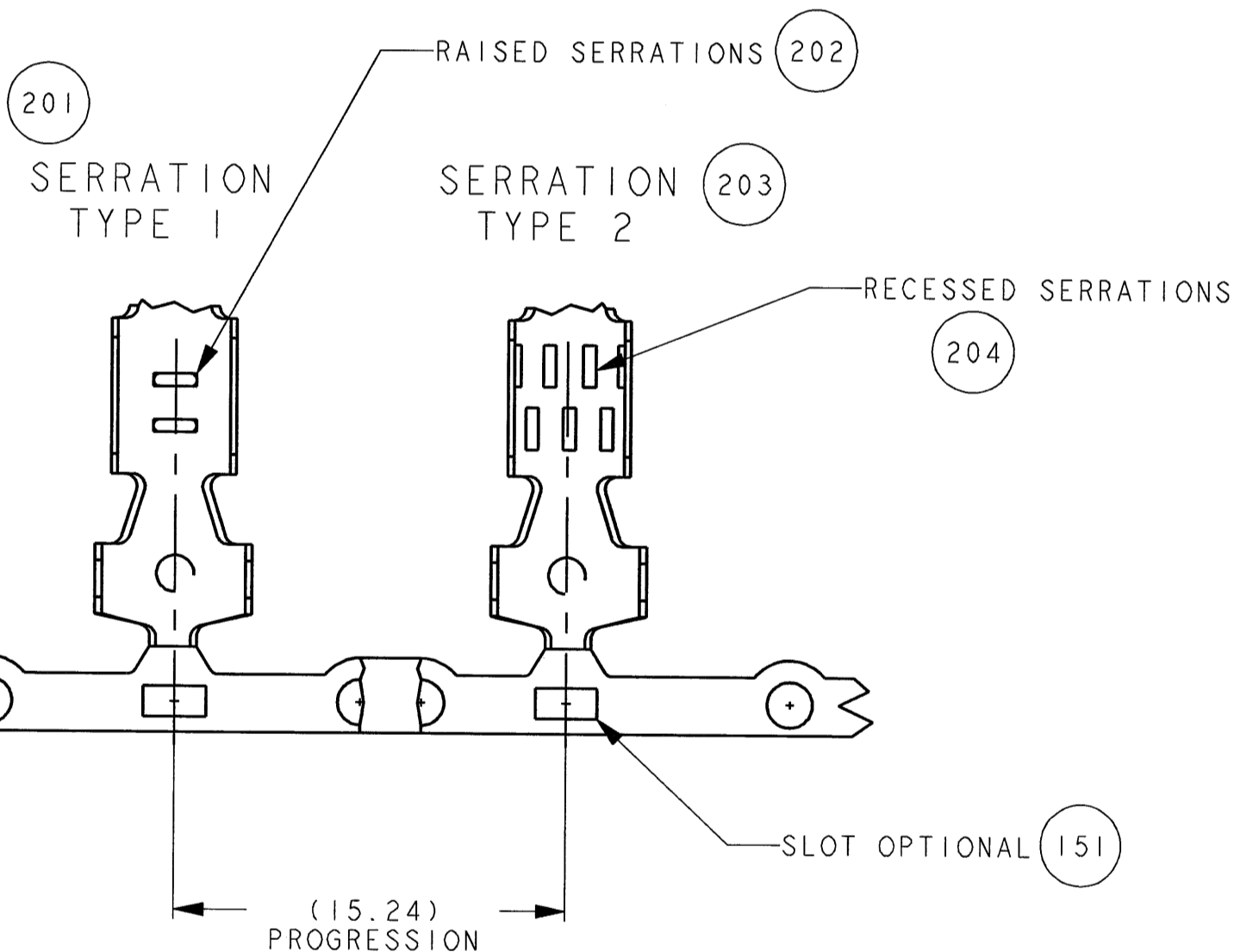

- NOTES:
- 1) CONFORMS TO ALL APPLICABLE SECTIONS OF SAE/USCAR-2 REV. 3 EXCEPT TERMINAL BEND RESISTANCE SECTION 5.2.2 SAE/USCAR-12 REV 2 SAE/USCAR-21 FORD SDS VER 11
 - 2) MATERIALS
 - (M) MATERIAL C14530 CU THICKNESS 0.305 ± 0.008
 - (N) PLATING OPTION 1: HOT TIN DIP 0.50 - 2.50µm
 - (O) SEE INSERT FOR GOLD PLATING MATERIAL ITEM ① REQUIREMENTS
 - (P) TENSILE STRENGTH: 372 - 442 Mpa
 - (Q) MIN. ELONGATION: 2.5% IN 51.0 mm
 - (R) GOLD PLATING OPTION RAW MATERIAL #47166
 - (S) BASE MAT'L C14530 CU FULL HARD
 - (T) TENSILE: 324-394 Mpa
 - (U) MIN. ELONGATION: 2.0%
 - (V) YIELD STRENGTH: 134-138 Mpa
 - (W) ITEM ② MATERIAL C17410 BE CU THICKNESS 0.203 ± 0.008
 - (X) PLATING OPTION 1: HOT TIN DIP 0.50-2.5µm THICK
 - (Y) SEE INSERT FOR GOLD PLATING MATERIAL ITEM ② REQUIREMENTS
 - (Z) TENSILE STRENGTH: 655-862 Mpa
 - (AA) MIN. ELONGATION: 7% IN 50mm
 - 3) TERMINAL SYMMETRICAL ABOUT CENTERLINE EXCEPT AS SHOWN.
 - 4) DIMENSIONAL TOLERANCE:
 - 1) PLACE ±0.25
 - 2) PLACE ±0.10
 - ANGULAR ±3°
 - 5) FOR CAVITY SPECIFICATION INFORMATION REFERENCE F.C.I. DRAWING 15001 FOR UNSEALED CAVITY AND F.C.I. DRAWING C15006 FOR SEALED CAVITY
 - 6) SEE USCAR DRAWING EWCAP-001 FOR DIRECT CONNECT MATING BLADE INFORMATION
 - 7) ANNUAL QUALITY REQUIREMENTS: IT IS PERMISSIBLE TO PERFORM CONTINUOUS CONFORMANCE PER FCI SPECIFICATION #AQA-001 INSTEAD OF ANNUAL LAYOUT & ANNUAL PV REQUIREMENTS OF QS-9000 SECTION 2 - CURRENT PRODUCTION TOOLING - POINT OF LAST RUN.
 - 8) THIS DRAWING REPLACES DCX DRAWING 04707167
 - 9) VENDOR, TOOL, GRIP & WEEK CODES MUST BE PRESENT & LEGIBLE
 - 10) QUALITY ASSURANCE REQUIREMENTS PER DCA PS-1300-2

UNCONTROLLED
FCI AUTOMOTIVE
JUL 27 2005
AMERICAS
FCI MASTER COPY WHEN IN RED

REV	DATE	BY	CHKD	DESCRIPTION
001	10/04/05	NA	023	JTP-1011-29 AND MS 8288
002	06/09/05	NA	058	MISSING DIMENSIONS RESTORED
003	07/12/05	NA	016	ASTM-B-545-02 WAS ASTM-B-545-03
004	07/12/05	NA	016	NYE UNIFLOR 8917 WAS NYE UNIFLOR 8917
005	07/12/05	NA	016	PLATING MATERIAL GREASE ADDED
006	02/15/05	NA	016	INSULATION GRIP TYPE NOS. & GRIP CODES CORRECTED IN CHART
007	11-19-04	NA	ALL	REVISED B DRAWING IN PRO-E REPLACED LVL

Mouser Electronics

Authorized Distributor

Click to View Pricing, Inventory, Delivery & Lifecycle Information:

[Aptiv:](#)

[54001000](#) [54001003](#) [54001202](#) [54001300](#) [54001400](#) [54001402](#) [54001404](#) [54001410](#) [54001444](#) [54001800](#)
[54001803](#) [54001807](#) [54001875](#) [54002200](#) [54001811](#) [54002203](#) [54001002](#) [54001208](#) [54001228](#) [54002202](#)
[54002262](#) [54001802](#) [54001403](#)