

Wide Selection of High Performance Small DC Sensors Offers Longer Sensing Distances

- Fast 0.5 msec response time for high-speed sensing
- Extended sensing distances up to 7 meters
- Self-diagnostic functions available
- Timer, alarm and turbo functions
- Meets: NEMA 4X, 6 and IP67
- Many mounting configurations available
- Choose pre-leaded or connector-ready models
- E3S-AD Series includes 10 cm short range diffuse version

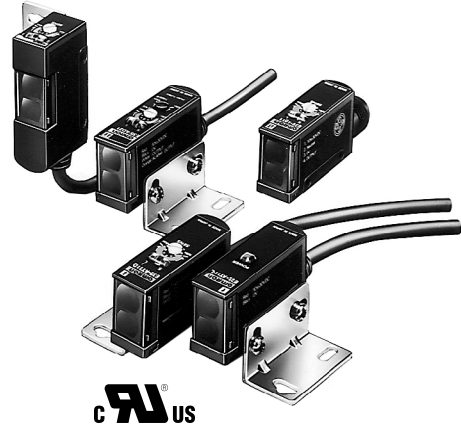

Ordering Information

■ SENSORS

Through-beam sensors include both emitter and receiver. The polarized retroreflective sensors include E39-R1 reflector. All sensors include mounting hardware. Optional mounting brackets are available as accessories.

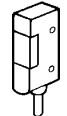
Method of detection				Through-beam	Polarized retroreflective	Diffuse reflective		
Sensing distance				7 m (22.97 ft)	2 m (6.56 ft)	10 cm (3.94 in)	20 cm (7.87 in)	70 cm (2.3 ft)
Mounting	Output	Extra features	Connection	Part number				
	NPN	None	Pre-leaded	E3S-AT11	E3S-AR11	E3S-AD13	E3S-AD11	E3S-AD12
		None	Connector	E3S-AT16	E3S-AR16	E3S-AD18	E3S-AD16	E3S-AD17
		Timer, alarm and turbo	Pre-leaded	E3S-AT21	E3S-AR21	E3S-AD23*	E3S-AD21	E3S-AD22*
	PNP	None	Pre-leaded	E3S-AT31	E3S-AR31	E3S-AD33	E3S-AD31	E3S-AD32
		None	Connector	E3S-AT36	E3S-AR36	E3S-AD38	E3S-AD36	E3S-AD37
		Timer, alarm and turbo	Pre-leaded	E3S-AT41	E3S-AR41	E3S-AD43*	E3S-AD41	E3S-AD42*
	NPN	None	Pre-leaded	E3S-AT61	E3S-AR61	E3S-AD63	E3S-AD61	E3S-AD62
		None	Connector	E3S-AT66	E3S-AR66	E3S-AD68	E3S-AD66	E3S-AD67
		Timer, alarm and turbo	Pre-leaded	E3S-AT71	E3S-AR71	E3S-AD73*	E3S-AD71	E3S-AD72*
	PNP	None	Pre-leaded	E3S-AT81	E3S-AR81	E3S-AD83	E3S-AD81	E3S-AD82
		None	Connector	E3S-AT86	E3S-AR86	E3S-AD88	E3S-AD86	E3S-AD87
		Timer, alarm and turbo	Pre-leaded	E3S-AT91	E3S-AR91	E3S-AD93*	E3S-AD91	E3S-AD92*

*10 and 70 cm diffuse versions do not have turbo function

■ ACCESSORIES

Description	Part number	
Mounting bracket for vertical sensors (2 required for through-beam type)	E39-L59	
Slits for E3S-AT□□ sensors (3 pairs: 2 mm, 1 mm and 0.5 mm wide, includes mounting hardware)	E39-S46	
Mutual interference filters for E3S-AT□□ sensors (2 pairs: horizontal and vertical, includes mounting hardware)	E39-E6	
Optical alignment reflector for E3S-AT□□	E39-R5	
Straight connector cordsets (4-pole female connector)	2 m (6.56 ft) cable	Y96E-43SD2
	5 m (16.40 ft) cable	Y96E-43SD5
	10 m (32.81 ft) cable	Y96E-43SD10
Right-angle connector cordsets (4-pole female connector)	2 m (6.56 ft) cable	Y96E-43RD2
	5 m (16.40 ft) cable	Y96E-43RD5
	10 m (32.81 ft) cable	Y96E-43RD10
Small corner cube reflector	10 to 130 cm (3.94 to 51.18 in)	E39-R3
	7 to 60 cm (2.76 to 23.62 in)	E39-R4
Adhesive back reflector	10 to 30 cm (3.94 to 11.81 in)	E39-RSA
	10 to 60 cm (3.94 to 23.62 in)	E39-RSB
Mounting bracket for E39-R1 reflector	E39-L7	

■ REPLACEMENT PARTS

Description	Part number
Knob for sensitivity adjuster	E39-G2
Mounting bracket spacer for connector versions	E39-L60
Corner cube reflector (supplied with E3S-AR□□)	E39-R1
Mounting bracket for horizontal sensors (supplied with each sensor)	E39-L69
Mounting bracket for vertical sensors (supplied with each sensor)	E39-L70

Specifications

Part number		E3S-AT□□	E3S-AR□□	E3S-AD□3, E3S-AD□8	E3S-AD□1, E3S-AD□6	E3S-AD□2, E3S-AD□7
Method of detection		Through-beam	Polarized retroreflective	Diffuse reflective		
Supply voltage		10 to 30 VDC, ±10%				
Current consumption		40 mA max. (emitter and receiver) 55 mA with turbo	30 mA max. 45 mA with turbo	35 mA max.	30 mA max. 45 mA with turbo	35 mA max.
Sensing distance	White mat paper	0 to 7 m (0 to 22.97 ft)	0.1 to 2 m with E39-R1 (0.33 to 6.56 ft)	0 to 10 cm (0 to 3.94 in)	0.1 to 20 cm (0.04 to 7.87 in)	0 to 70 cm (0 to 27.56 in)
	Black mat paper			0.3 to 2.5 cm (0.12 to 0.98 in)	0.5 to 2.3 cm (0.20 to 0.91 in)	0.15 to 33 cm (0.06 to 12.99 in)
	With accessories	2.4 m (7.87 ft) with E39-E6 2.5 m (8.20 ft) with 2 mm slit 1.1 m (3.61 ft) with 1 mm slit 0.5 m (1.64 ft) with 0.5 mm slit	10 to 130 cm with E39-R3 (3.94 to 51.18 in) 7 to 60 cm with E39-R4 (2.76 to 23.62 in) 10 to 30 cm with E39-RSA (3.94 to 11.81 in) 10 to 60 cm with E39-RSB (3.94 to 23.62 in)	—	—	—
Light source		Pulse modulated red LED (700 nm)		Pulse modulated infrared LED (880 nm)	Pulse modulated red LED (700 nm)	Pulse modulated infrared LED (880 nm)
Standard object	Type	Opaque materials		Opaque and transparent materials		
	Size	7 mm (0.28 in) minimum	30 mm (1.18 in) minimum	10 x 10 cm (3.94 x 3.94 in) white mat paper		20 x 20 cm (7.87 x 7.87 in) white mat paper
Operation mode		Light-ON/Dark-ON operation, wire selectable				

SPECIFICATIONS (continued)

Part number		E3S-AT□□	E3S-AR□□	E3S-AD□3, E3S-AD□8	E3S-AD□1, E3S-AD□6	E3S-AD□2, E3S-AD□7
Variation in sensing distance		—	—	+30% max., -0% max.		
Hysteresis		—	—	10% max.		20% max.
Variation in optical axis and mounting direction		±2° max.				
Sensitivity		Adjustable, 2-turn knob with clutch and indicator				
Mutual interference protection		Not provided	Provided	Provided	Provided	Provided
Control output	Type	NPN transistor, open collector (E3S-A□1□, E3S-A□2□, E3S-A□6□, E3S-A□7□), (E3S-AD1□, E3S-AD2□, E3S-AD6□, E3S-AD7□) PNP transistor, open collector (E3S-A□3□, E3S-A□4□, E3S-A□8□, E3S-A□9□), (E3S-AD3□, E3S-AD4□, E3S-AD8□, E3S-AD9□)				
	Max. load	100 mA max. at 30 VDC				
	Max. ON-state voltage drop	1 VDC max. at 100 mA load current				
Self-diagnostics alarm output		50 mA max. load at 30 VDC, NPN or PNP transistor open collector to match control output				
Response time		0.5 ms max. ON, 0.5 ms max. OFF				
OFF-delay timer		0 to 100 ms with 3/4 turn adjuster				
Check input	NPN	Light OFF: gray wire connected to 0 to 1.5 VDC	—	—	—	—
	PNP	Light OFF: gray wire connected to supply voltage (30 VDC max.)	—	—	—	—
	Response time	0.5 ms max.	—	0.5 ms max.		
Circuit protection		Load short-circuit protection, reverse polarity protection				
Indicators		Emitter: Operation (red) Receiver: Operation (red) Stability (green)	Operation (red), Stability (green)			
Materials	Lens	Denatured polyarylate				
	Case	Polybutylene terephthalate (PBT)				
	Bracket	Stainless steel				
Mounting		Either side surface with two threaded holes. Bracket E39-L69 for horizontal or E39-L70 for vertical sensors and hardware included.				
Connections	Prewired	2 m (6.56 ft) long cable				
	Connector	M12 threaded connector, 4 pin				
Weight	Prewired	Emitter: 60 g (2.1 oz.) Receiver: 60 g (2.1 oz.)	60 g (2.1 oz.)	60 g (2.1 oz.)	60 g (2.1 oz.)	60 g (2.1 oz.)
	Connector	Emitter: 11 g (0.4 oz.) Receiver: 11 g (0.4 oz.)	11 g (0.4 oz.)	11 g (0.4 oz.)	11 g (0.4 oz.)	11 g (0.4 oz.)
Enclosure rating	IEC 144	IP67				
	NEMA	4X, 6				
Ambient temperature	Operating	-25° to 55°C (-13° to 131°F) with no ice build-up				
	Storage	-40° to 70°C (-40° to 158°F)				

Operation

■ OUTPUT CIRCUIT DIAGRAMS

NPN Cable Type

Through-beam emitter E3S-AT11, E3S-AT61

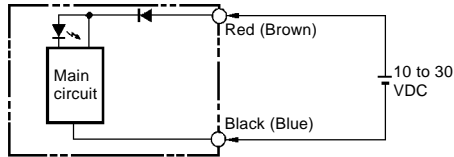

NOTE: IEC colors are shown in parentheses.

NPN Cable Type with Self-Diagnostic Functions

Through-beam emitter E3S-AT21, E3S-AT71

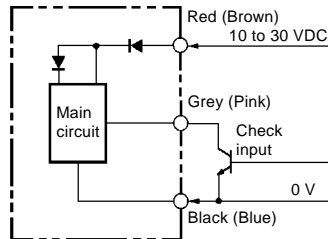

Through-beam receiver E3S-AT11, E3S-AT61

Retroreflective E3S-AR11, E3S-AR61

Diffuse reflective E3S-AD11, E3S-AD12, E3S-AD13, E3S-AD61, E3S-AD62, E3S-AD63

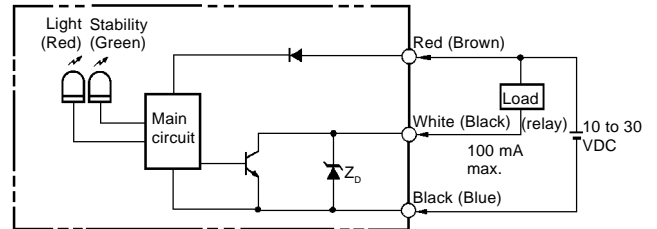

Through-beam receiver E3S-AT21, E3S-AT71

Diffuse reflective E3S-AD21, E3S-AD22, E3S-AD71, E3S-AD72

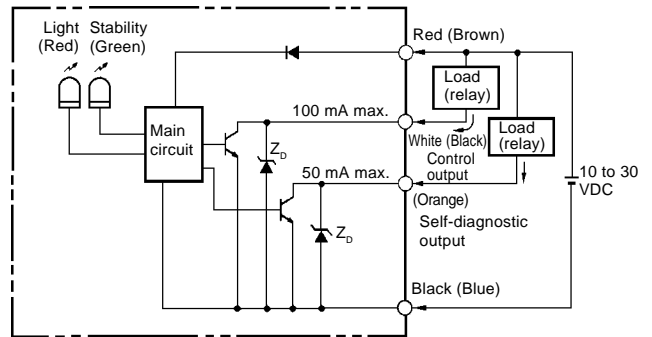

NPN Cable Type with Alarm Output

Diffuse reflective E3S-AD23, E3S-AD73

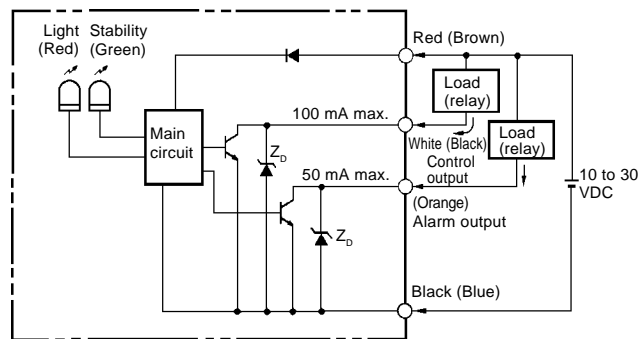

NPN Cable Type with Self-Diagnostic Functions

Retroreflective E3S-AR21, E3S-AR71

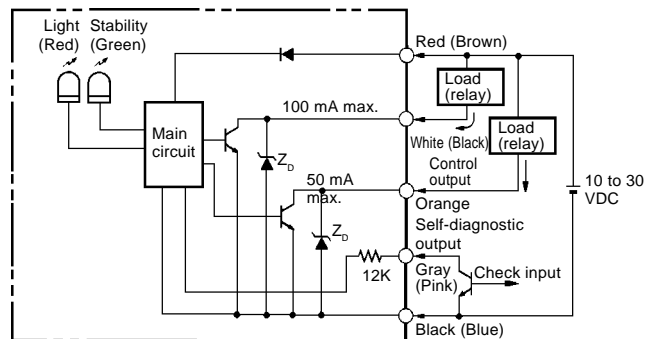

NPN Connector Type

Through-beam emitter E3S-AT16, E3S-AT66

Through-beam receiver E3S-AT16, E3S-AT66

Retroreflective E3S-AR16, E3S-AR66

Diffuse reflective E3S-AD16,

E3S-AD17, E3S-AD18, E3S-AD66,

E3S-AD67, E3S-AD68

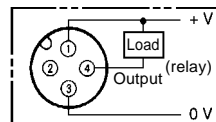
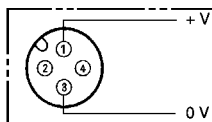

PNP Cable Type

Through-beam emitter E3S-AT31, E3S-AT81

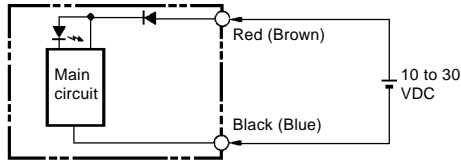

NOTE: IEC colors are shown in parentheses.

Through-beam receiver E3S-AT31, E3S-AT81
 Retroreflective E3S-AR31, E3S-AR81
 Diffuse reflective E3S-AD31, E3S-AD32, E3S-AD33,
 E3S-AD81, E3S-AD82, E3S-AD83

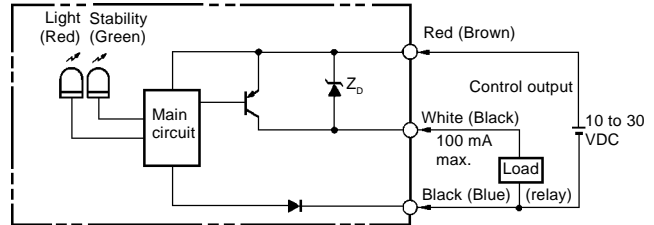

PNP Cable Type with Self-Diagnostic Functions

Through-beam emitter E3S-AT41, E3S-AT91

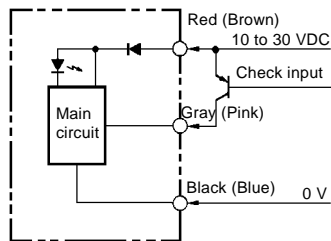

Through-beam receiver E3S-AT41, E3S-AT91
 Diffuse reflective E3S-AD41, E3S-AD42, E3S-AD91, E3S-AD92

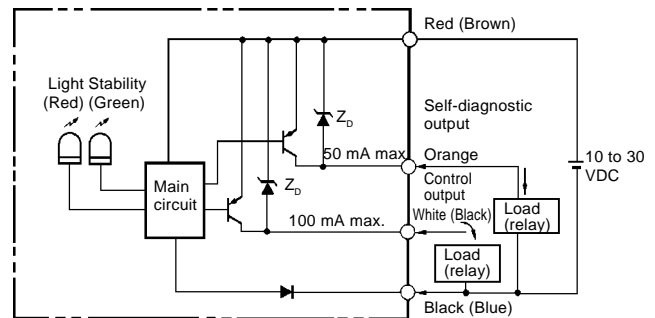

PNP Cable Type with Alarm Output

Diffuse reflective E3S-AD43, E3S-AD93

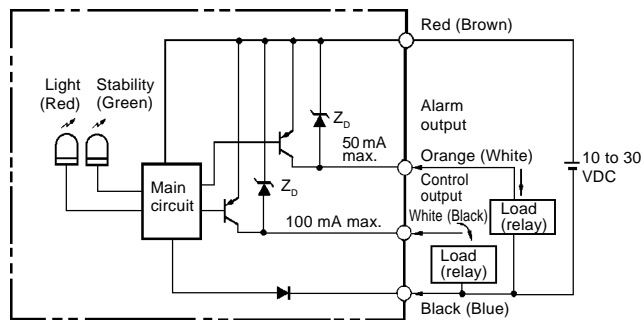

Retroreflective E3S-AR41, E3S-AR91

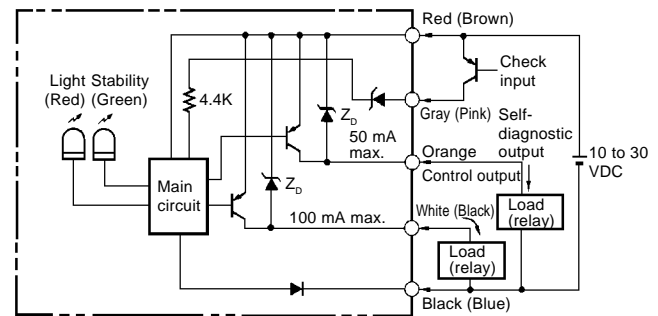

PNP Connector Type

Through-beam emitter E3S-AT36, E3S-AT86
 Through-beam receiver E3S-AT36, E3S-AT86
 Retroreflective E3S-AR36, E3S-AR86
 Diffuse reflective E3S-AD36,
 E3S-AD37, E3S-AD38, E3S-AD86,
 E3S-AD87, E3S-AD88,

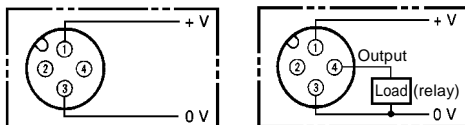

NOTE: IEC colors are shown in parentheses.

Engineering Data

EXCESS GAIN RATIO

Excess Gain vs. Set Distance
(Typical) E3S-AT□1

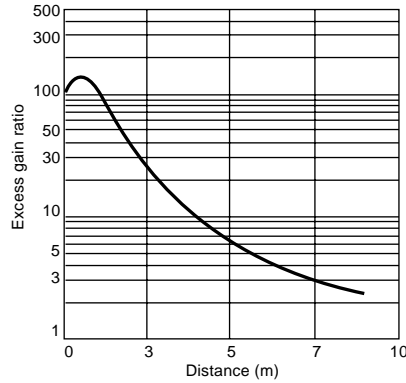

E3S-AD□1, -AD□2 (Detection of White Paper)

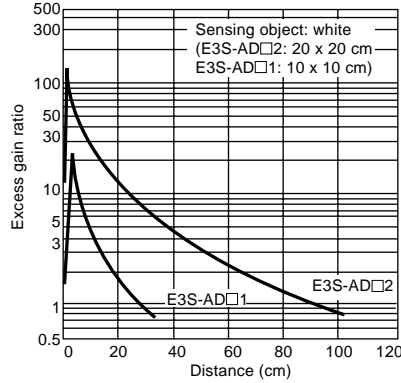

E3S-AD□1, -AD□2 (Detection of Black Paper)

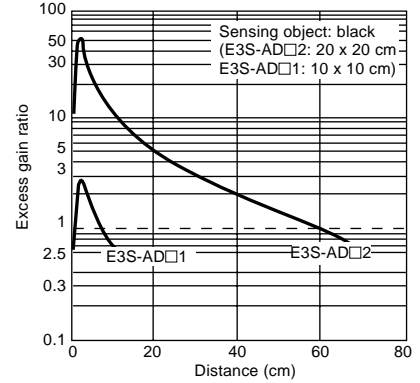

E3S-AD□1, -AD□2 (White Paper within Short Distance)

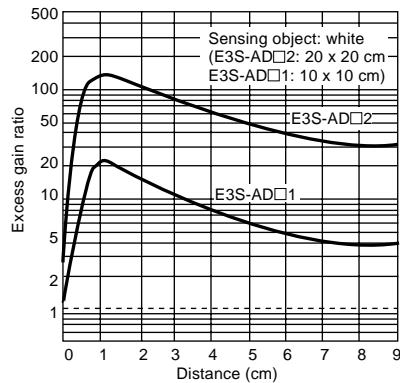

E3S-AD□1, -AD□2 (Black Paper within Short Distance)

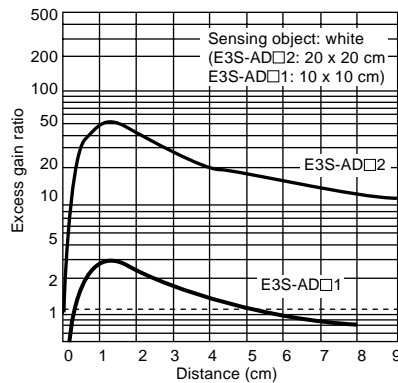

E3S-AD□3, -AD□8 (Detection of White Paper)

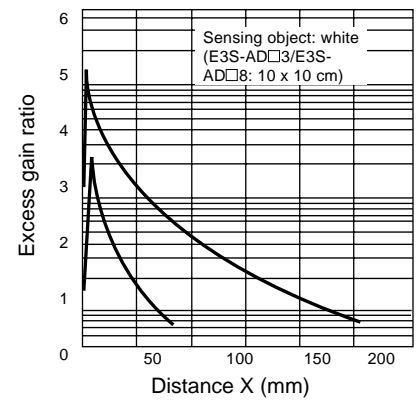

E3S-AD□3, -AD□8 (Detection of Black Paper)

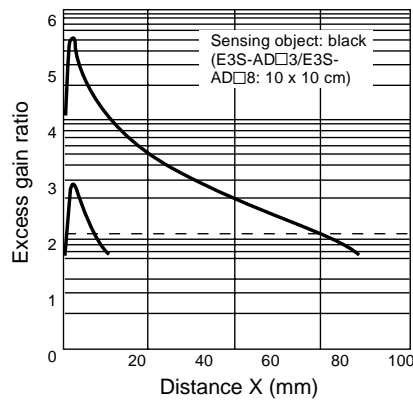

E3S-AR□1 (With Reflector: E39-R1)

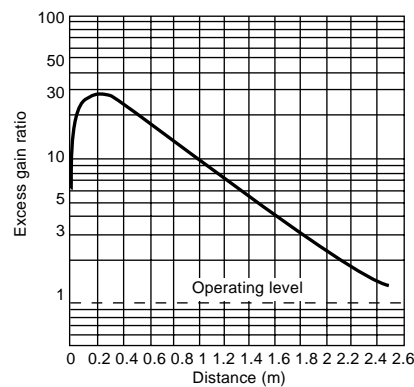

OPERATING RANGE

Parallel Operating Range (Typical)

E3S-AT□1

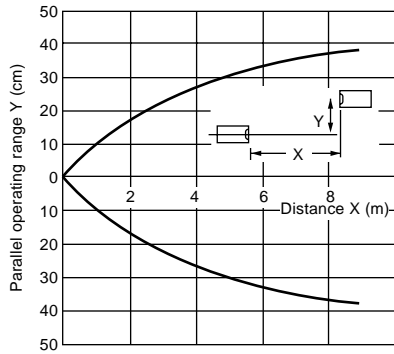

Operating Range (Typical)

E3S-AD□1

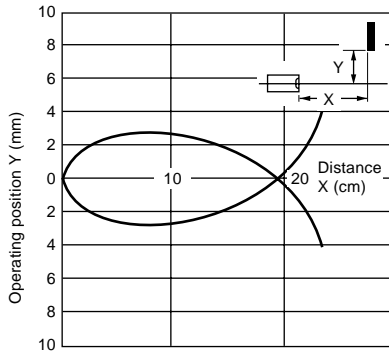

E3S-AD□2

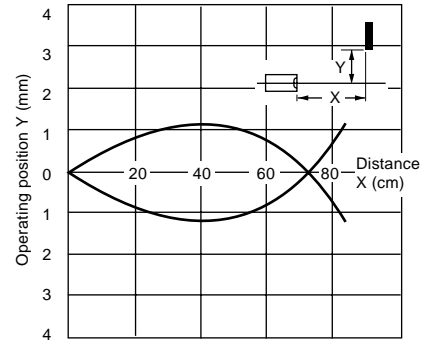

OPERATING RANGE (typical)

E3S-AD□3, E3S-AD□8 (Left and Right)

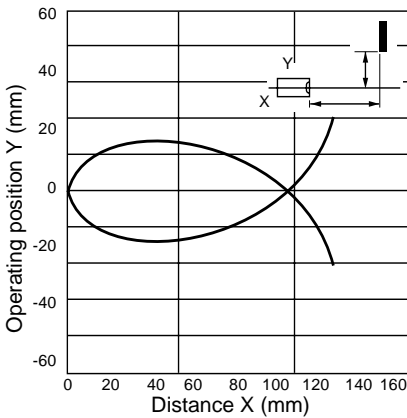

E3S-AD□3, E3S-AD□8 (Up and Down)

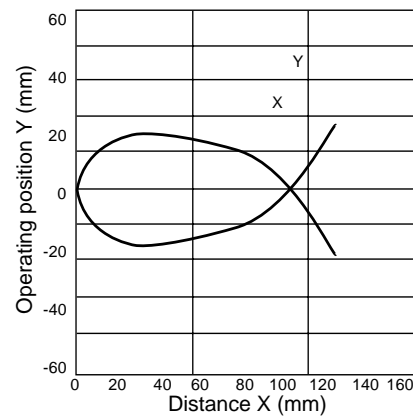

SENSING DISTANCE VS. OBJECT SIZE

E3S-AD□3, E3S-AD□8

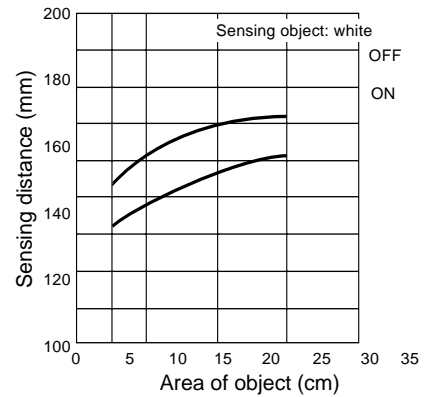

SENSING DISTANCE VS. OBJECT SIZE

E3S-AD□1

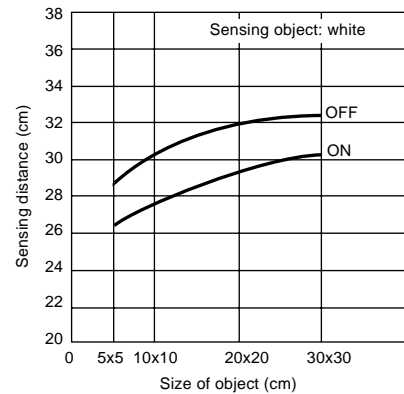

E3S-AD□2

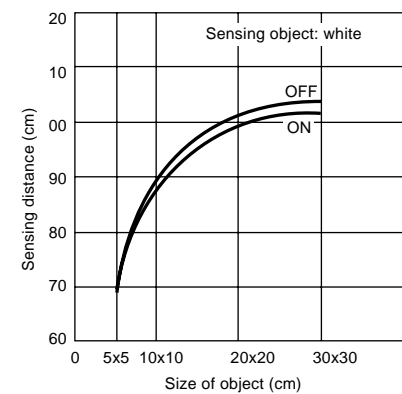

REFLECTOR PARALLEL MOVEMENT

(Typical) E3S-AR□1

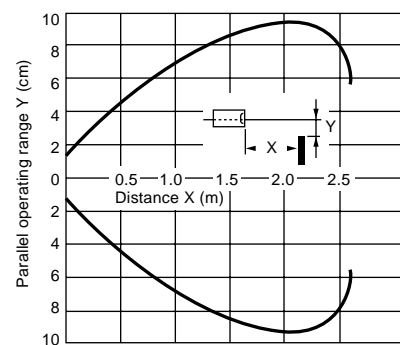

Dimensions

Unit: mm (inch)

■ SENSORS

**E3S-AD11, E3S-AD12, E3S-AD13, E3S-AD31, E3S-AD32,
E3S-AD33 (see note 1), E3S-AD21, E3S-AD22,
E3S-AD23, E3S-AD41, E3S-AD42, E3S-AD43**
Receiver: **E3S-AT11, E3S-AT31 (see note 2)**
E3S-AT21, E3S-AT41

Emitter: **E3S-AT11, E3S-AT31 (see note 3)**
E3S-AT21, E3S-AT41

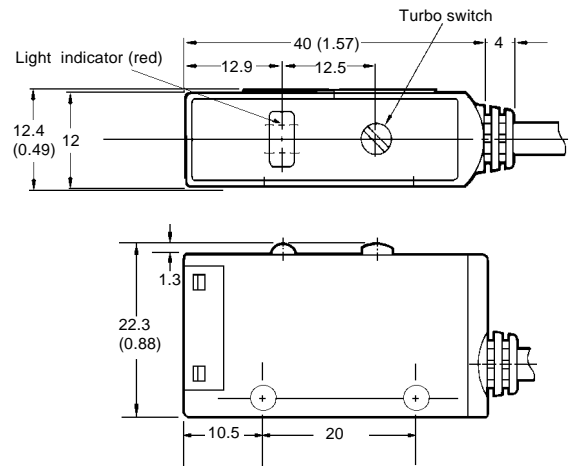
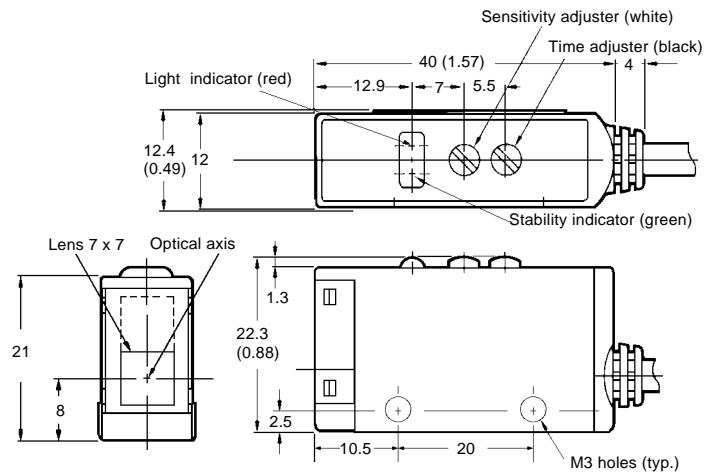

**E3S-AD61, E3S-AD62, E3S-AD63, E3S-AD81, E3S-AD82,
E3S-AD83 (see note 1), E3S-AD71, E3S-AD72, E3S-AD73,
E3S-AD91, E3S-AD92, E3S-AD93**
Receiver: **E3S-AT61, E3S-AT81 (see note 2)**
E3S-AT71, E3S-AT91

Emitter: **E3S-AT61, E3S-AT81 (see note 3)**
E3S-AT71, E3S-AT91

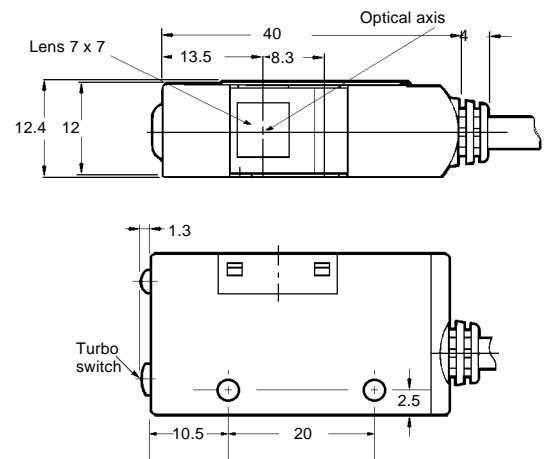
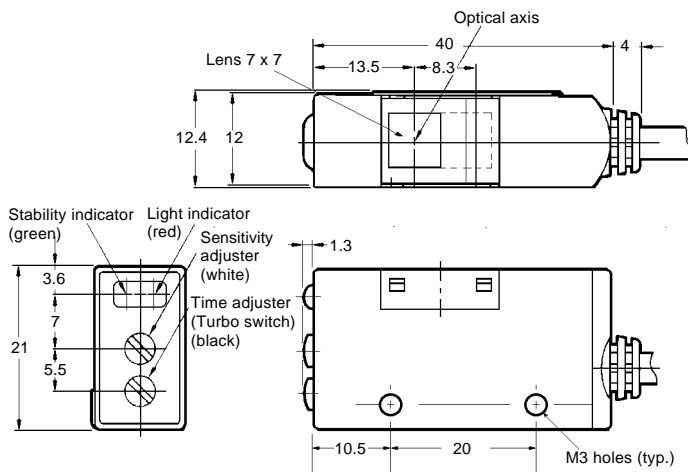

NOTES: 1. No time adjuster/turbo included on models E3S-AD61, E3S-AD62, E3S-AD81 and E3S-AD82.
2. No time adjuster included on models E3S-AT61 and E3S-AT81.
3. No turbo switch included on models E3S-AT61 and E3S-AT81.

SENSORS (continued)

E3S-AD16, E3S-AD17, E3S-AD18, E3S-AD36, E3S-AD37, E3S-AD38

Receiver: E3S-AT16, E3S-AT36

Emitter: E3S-AT16, E3S-AT36

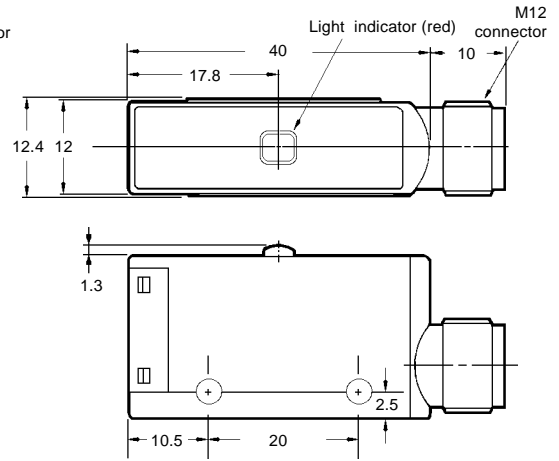
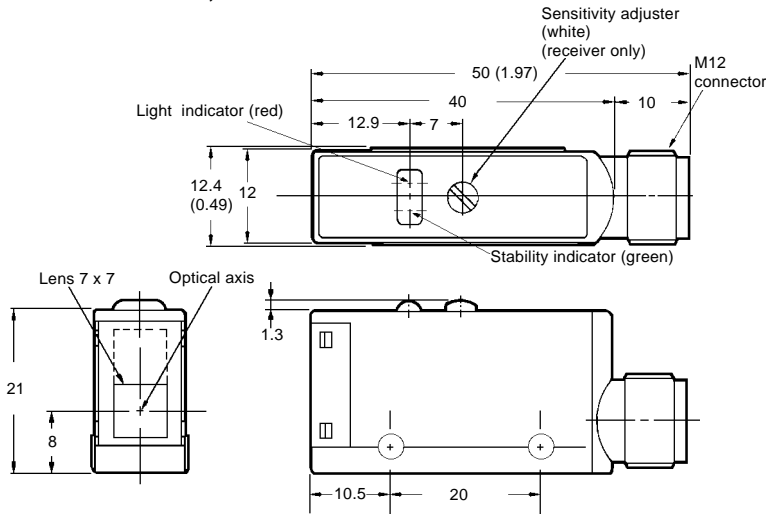

E3S-AD66, E3S-AD67, E3S-AD68, E3S-AD86, E3S-AD87, E3S-AD88

Receiver: E3S-AT66, E3S-AT86

Emitter: E3S-AT66, E3S-AT86

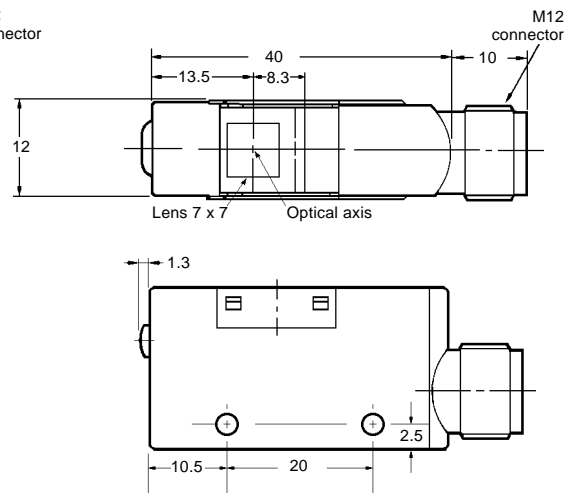
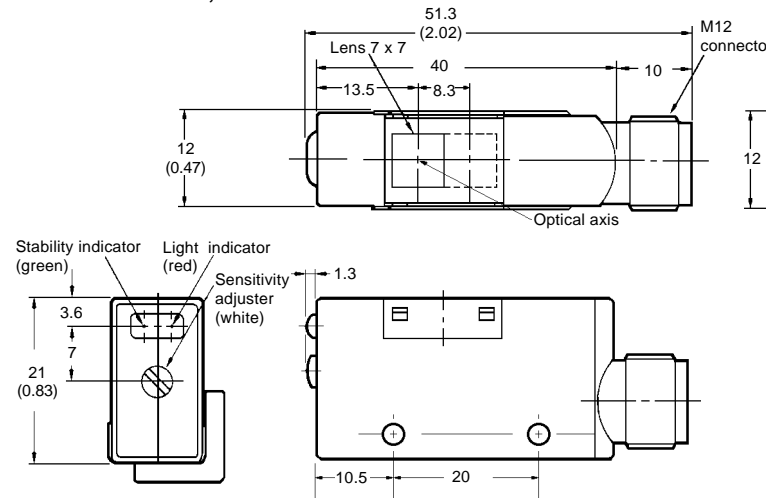

E3S-AR11, E3S-AR31 (see note)

E3S-AR21, E3S-AR41

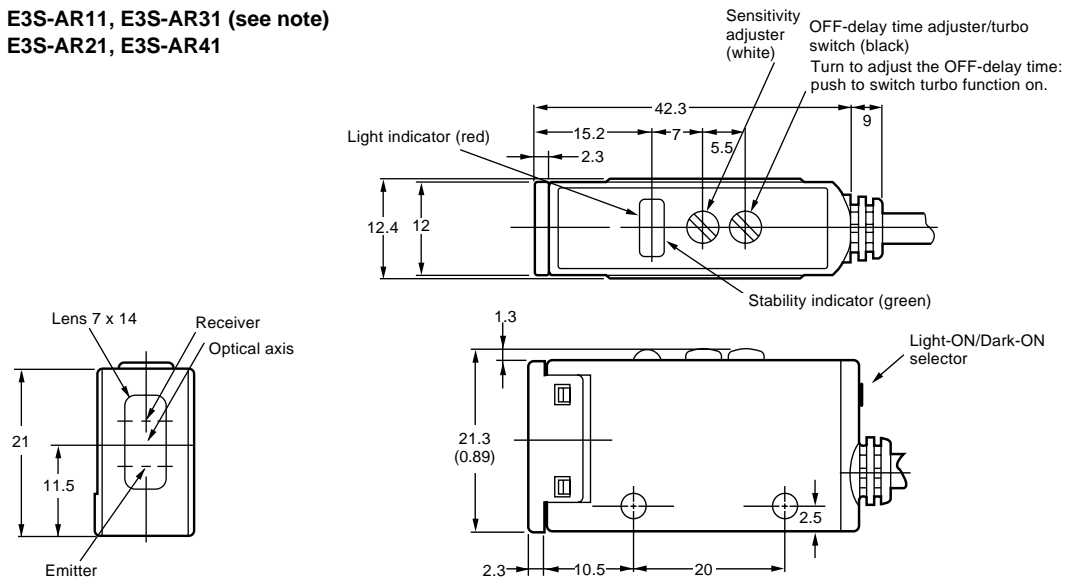

NOTE: No time adjuster/turbo included on models E3S-AR11 and E3S-AR31.

SENSORS (continued)

E3S-AR61, E3S-AR81

E3S-AR71, E3S-AR91

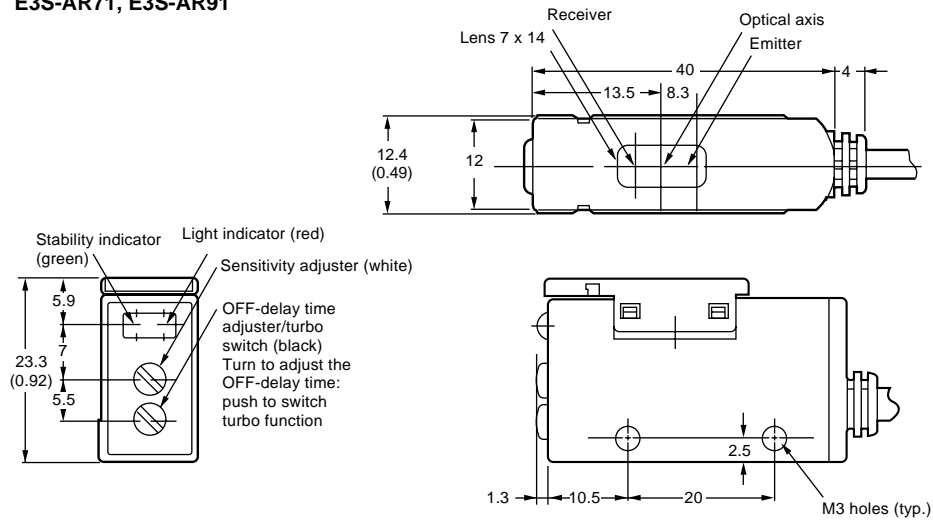

E3S-AR16, E3S-AR36

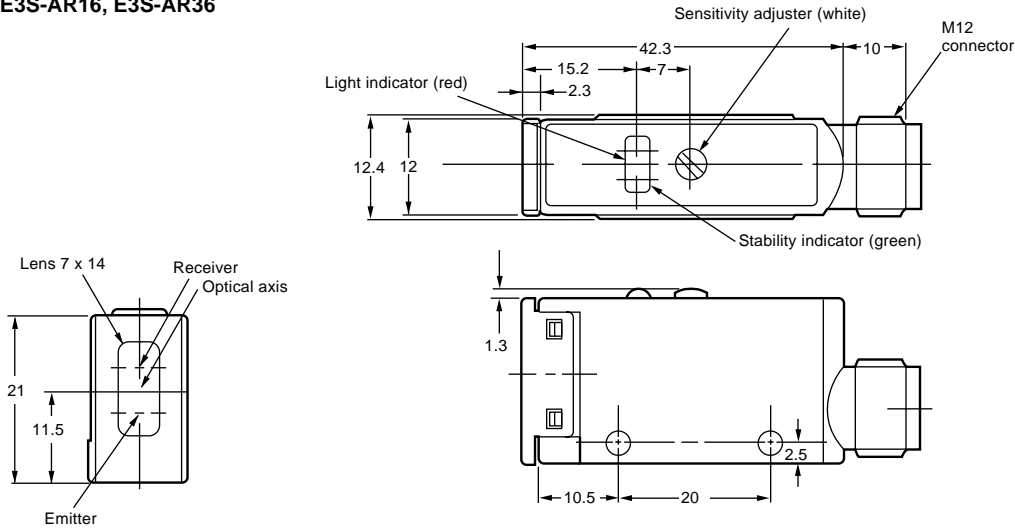

E3S-AR66, E3S-AR86

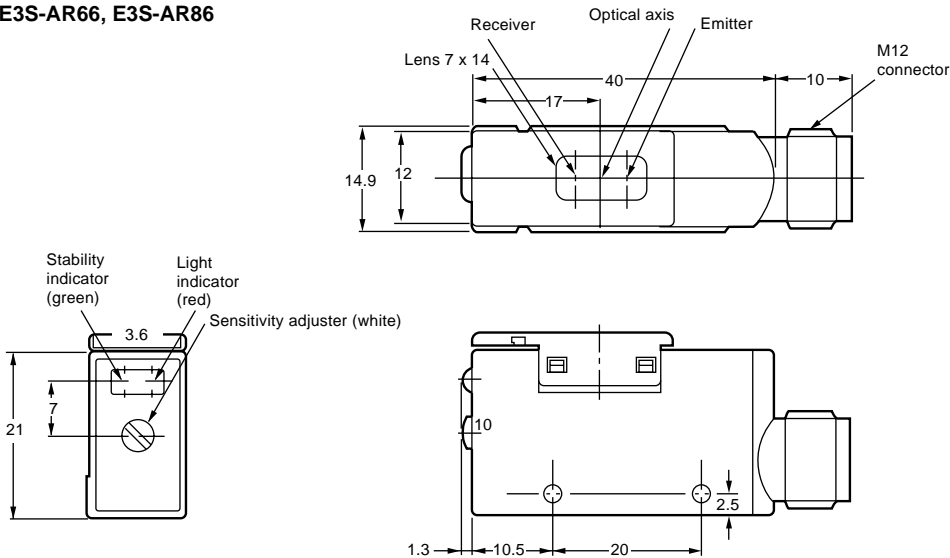

OPTIONAL CONNECTOR CORDSETS

Cordsets consist of a female connector and 3-conductor, 22 AWG, PVC jacketed cable rated for 300 V, 90°C. The cable may be extended to a maximum of 200 m (656 ft).

Straight Connector Cordsets Y96E-43SD□

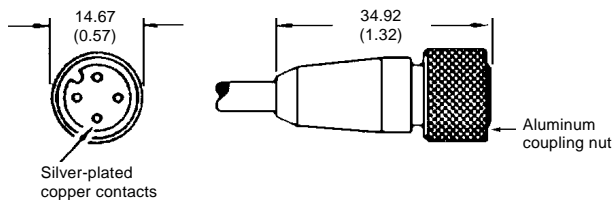

- 2 m (6.56 ft) length for Y96E-43SD2
- 5 m (16.40 ft) length for Y96E-43SD5
- 10 m (32.81 ft) length for Y96E-43SD10

Face View, Female Connector

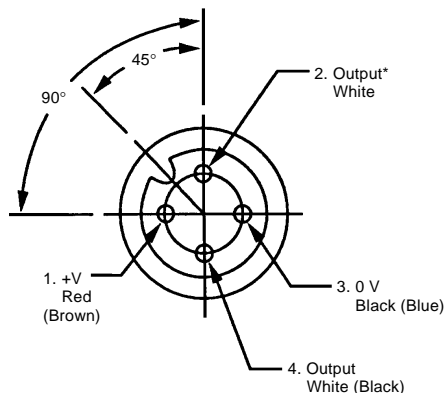

NOTES:
 *Not used on 3-wire models.
 IEC colors are shown in parentheses.

Right Angle Connector Cordsets Y96E-43RD□

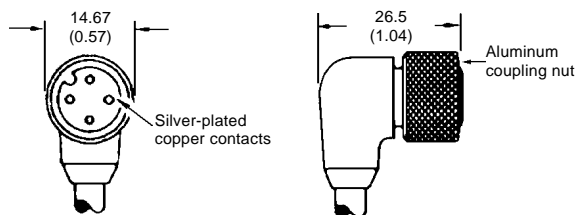

- 2 m (6.56 ft) length for Y96E-43RD2
- 5 m (16.40 ft) length for Y96E-43RD5
- 10 m (32.81 ft) length for Y96E-43RD10

CORNER CUBE REFLECTORS

E39-R1 Reflector (included with E3S-AR□□)

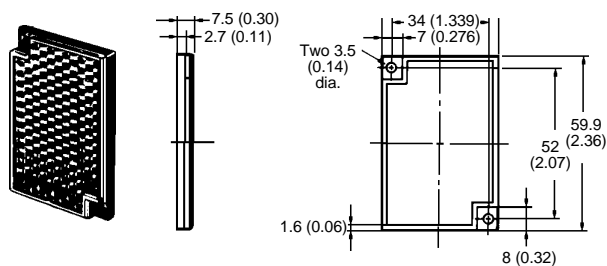

E39-L7 Reflector Adapter for E39-R1 Reflector

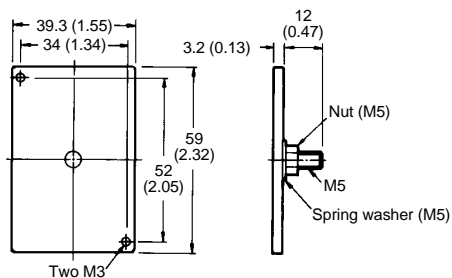

■ CORNER CUBE REFLECTORS (continued)

E39-R3 Optional Reflector

Dimensions with E39-L54 Mounting Bracket (included)

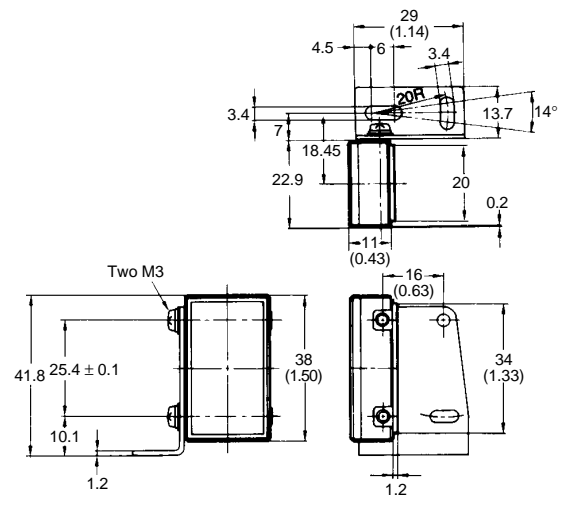
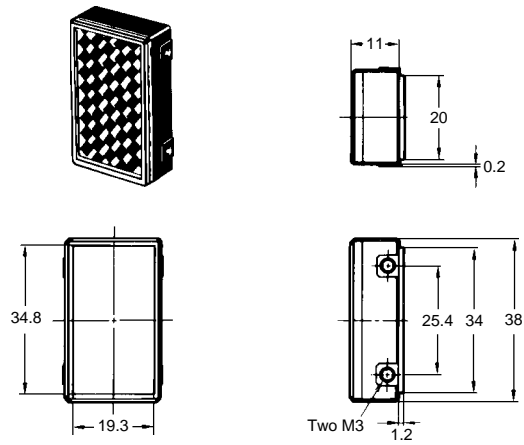

E39-R4 Optional Mini-reflector

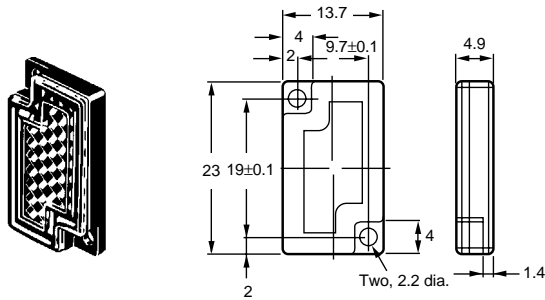

E39-RSA Optional Adhesive-backed Reflector

E39-RSB Optional Adhesive-backed Reflector

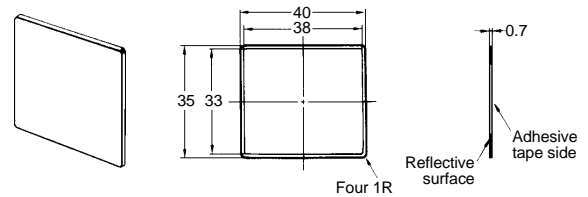
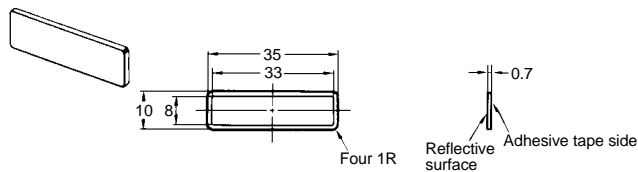

■ OPTICAL AXIS CONFIRMATION REFLECTOR

E39-R5 for E3S-A Sensors

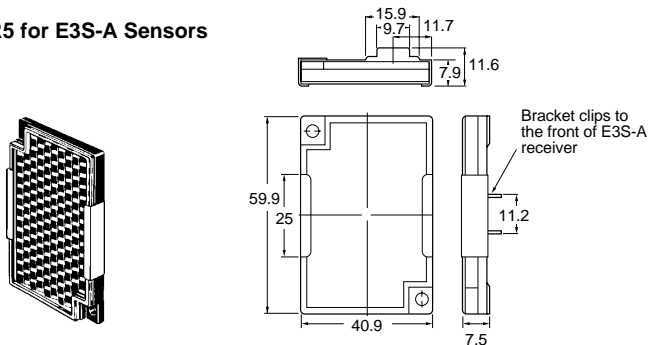

■ SLITS AND FILTERS

E39-S46 Slits

Kit for through-beam sensors contains 0.5 mm, 1 mm and 2 mm wide slits and mounting frame.

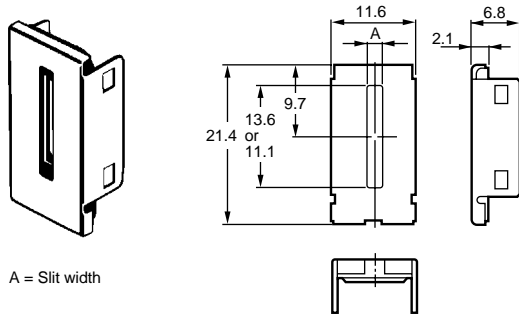

E39-E6 Mutual Interference Filter

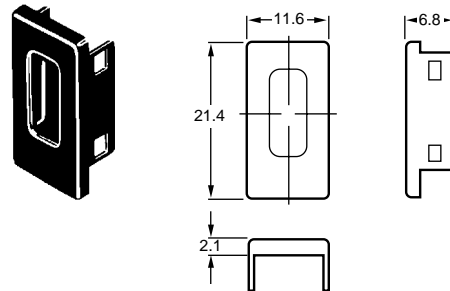

■ MOUNTING SPACER FOR CONNECTOR-TYPE SENSORS

E39-L60 Spacer

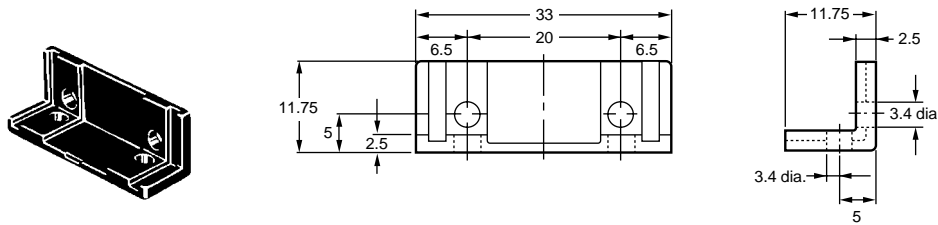

■ MOUNTING BRACKETS (supplied with sensors)

E39-L69 Mounting Bracket

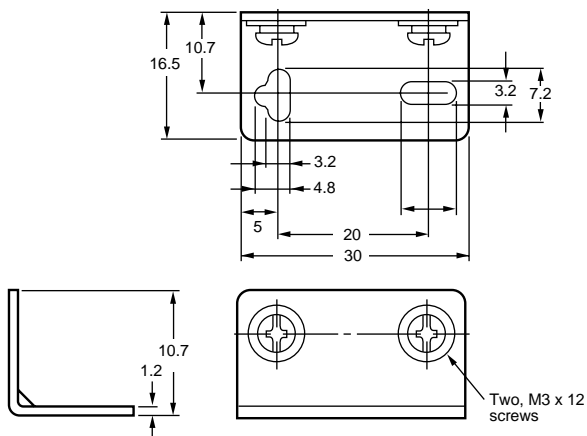

E39-L70 Mounting Bracket

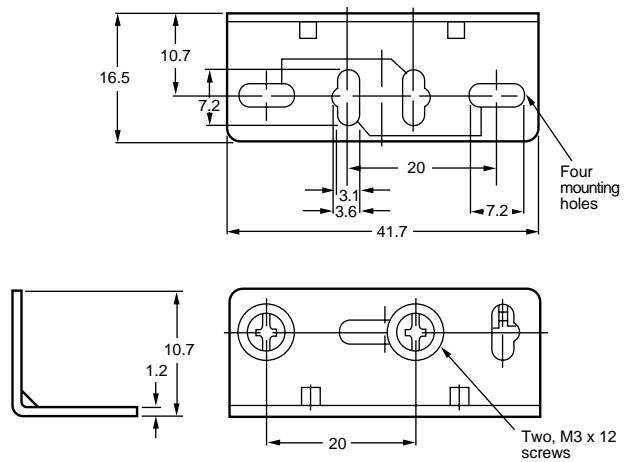

■ E39-L59 OPTIONAL VERTICAL MOUNTING BRACKET

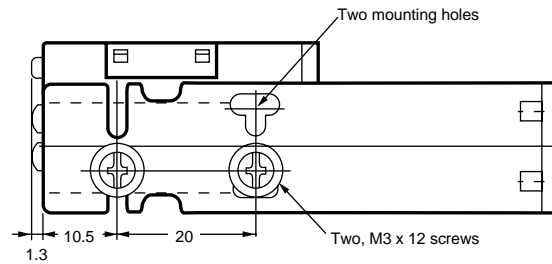
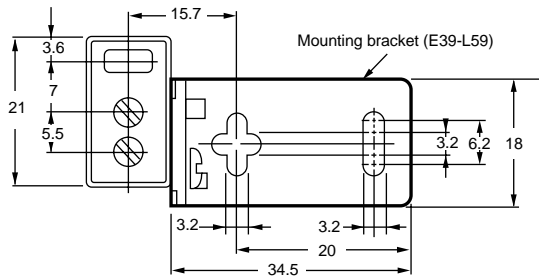
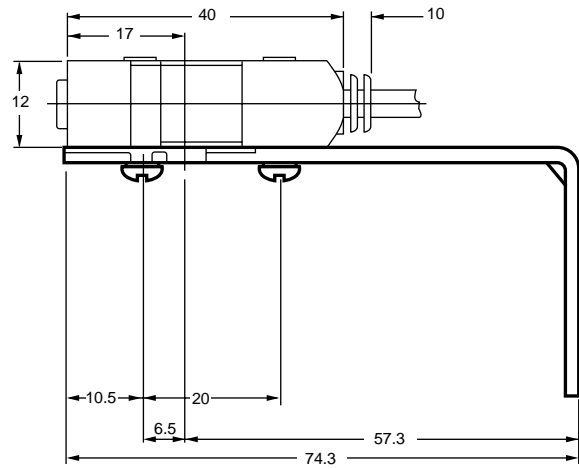
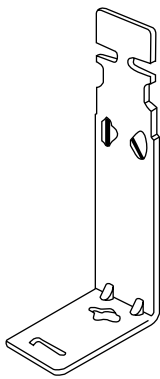

■ E39-G2 SENSITIVITY ADJUSTER KNOB

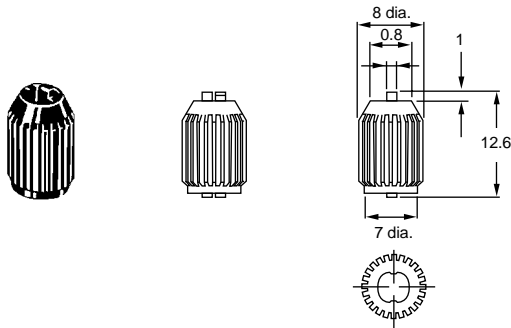

■ MOUNTING BRACKET NOTCH

Each mounting bracket slot has a notch to provide a center position for aligning the sensor parallel to the bracket. This ensures that the beam is aligned with the mounting surface.

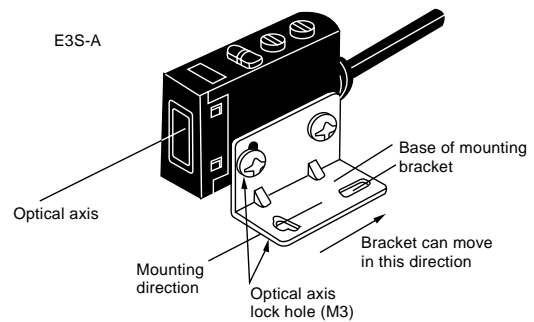

Installation

■ SENSITIVITY ADJUSTMENT

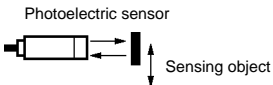
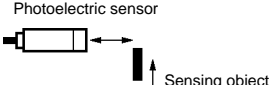
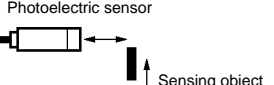
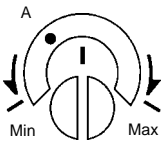
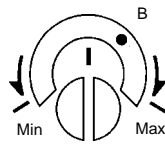
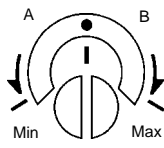
Steps	Step 1	Step 2	Step 3
Function	Determine Position A	Determine Position B	Adjust to optimum setting
Sensing Condition			
Sensitivity adjuster			
Indicators	OFF <input type="radio"/> STABILITY (green) ON <input checked="" type="radio"/> LIGHT (red)	OFF <input type="radio"/> STABILITY (green) OFF <input type="radio"/> LIGHT (red)	ON <input checked="" type="radio"/> STABILITY (green) OFF <input type="radio"/> LIGHT (red)
Procedure	Place target at the desired sensing distance. Set sensitivity adjuster to the minimum scale position, and gradually increase sensitivity by turning the sensitivity adjuster clockwise until the Light Incident indicator (red LED) turns ON. Position A designates the point at which the LED has turned ON.	Remove the target. Starting from the maximum scale position, gradually decrease sensitivity by turning the sensitivity adjuster counterclockwise until the Light Incident indicator (red LED) turns OFF. Position B designates the point at which the LED has turned OFF.	Set the sensitivity indicator to the position between Positions A and B (in some cases, Positions A and B are opposite of the above example). The photoelectric sensor will then work normally if the stability indicator (green) is lit with and without the target. If it is not lit, stable operation cannot be expected, in which case a different detection method should be applied.

Unlike conventional photoelectric sensors, the variation in the sensitivity of E3S photoelectric sensors is minimal. This means the sensitivity can be adjusted on only a single photoelectric sensor, and then the adjusters on the other photoelectric sensors can be set to the same scale position. There is no need to adjust the sensitivity of each photoelectric sensor individually.

■ TIMER AND TURBO SWITCH

E3S Sensors equipped with the self-diagnostic feature incorporate an OFF-delay timer that can be adjusted within range of 0 to 100 ms.

The emitter of the through-beam sensor with the self-diagnostic feature incorporates a turbo switch. When this switch is on, the intensity of the red LED light source can be increased to make a brighter spot. The OFF-delay time adjuster of the retroreflective and the 20-cm diffuse reflective sensor is used as a turbo switch. When the adjuster is pressed, it functions as a turbo switch to automatically increase the power of the light source to create a brighter light spot. Do not press the adjuster when turning it.

Turbo Function (Turbo Switch)

With the turbo function switched ON, the light spot is visible even at a distance of 20 cm (7.87 in), making it easy to check the sensing position and the angle of the optical axis.

- After using the turbo function, readjust the OFF-delay time that had been set, since the OFF-delay time could have been changed when the turbo switch (which is on the OFF-delay time adjuster) was pressed.

- Press the OFF-delay time adjuster to switch ON the turbo function with a maximum force of 1 kg and within a maximum period of 3 minutes. (The photoelectric sensor, however, will not malfunction even if the turbo function is switched on for more than 3 minutes.)

The turbo function is effective with the turbo switch pressed, and the function is reset automatically when released.

With Turbo Switch ON

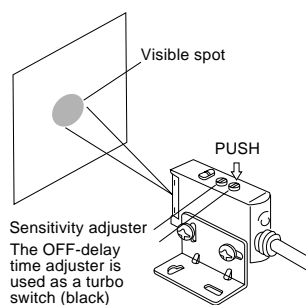



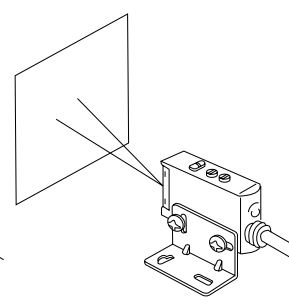





Normal Operating Condition

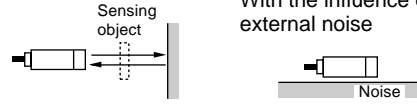

Self-Diagnostic Function

With this function, the E3S-A sensor checks changes in environmental conditions (especially a change in the ambient temperature) and self-diagnoses the resistance against the changes. The result is shown by the indicators or an output signal.

Amount of incident light	Incident light indicator (red)	Indicator	Green Indicator	Self-diagnostic function	Self-diagnostic example
1.2 or more	With light incident (red indicator: ON)	 Green Red	Stable operating state with incident light: Stable operation is expected in the rated temperature range with the green indicator ON.	—	—
1.0 to 1.2		 Green Red	Conditional operating state with incident light: Stable operation is expected if the temperature fluctuation is within $\pm 10\%$ of the primary temperature.	The self-diagnostic alarm output alerts the user to this state if it continues for 0.3 s.	The optical axis misaligned by vibration.  Light decreased by dust. 
0.8 to 1.0	Without light incident (red indicator: OFF)	 Green Red			With light leakage (through-beam and retroreflective sensors)  Light reflected from the floor or the background (diffuse reflective sensors)  With the influence of external noise 
0.8 or less		 Green Red	Stable operating state with no incident light: Stable operation is expected in the rated temperature range with the green indicator ON.	—	—

EXTERNAL DIAGNOSTIC INPUT FUNCTION

To switch the emission off, short-circuit the gray (pink) and the black (blue) cords of the emitter of the E3S-AT□ or the E3S-AR□ with the NPN output feature. For the E3S-AR□ with the PNP output feature, short-circuit the gray (pink) and the red (brown) cords.

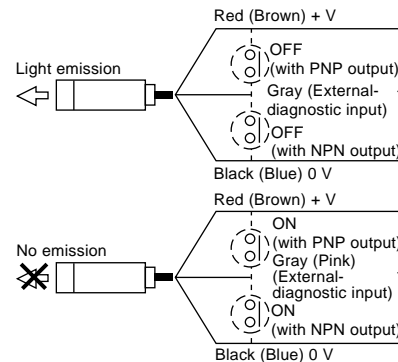

NOTE: IEC colors are shown in parentheses.

■ SLITS FOR THROUGH-BEAM SENSORS

E39-S46 Slit Set

Using slits allows smaller objects to be detected and reduces the sensing distance.

Slit width	Sensing distance	Min. object size
0.5 mm	0.5 m (1.64 ft)	0.5 mm (0.02 in)
1 mm	1.1 m (3.61 ft)	1 mm (0.04 in)
2 mm	2.4 m (8.20 ft)	2 mm (0.08 in)

Use the rubber attachment with the metal cover if a slit width of 2 mm is required. Insert the 0.5- or 1-mm slit between the metal cover and rubber attachment if a slit width of 0.5 or 1 mm is desired. These slits fit into the rubber attachment.

NOTE: Apply the slit to the lens of the photoelectric sensor marked with an arrow indicating the position of the optical axis (apply it to the bottom lens of horizontal sensors and the top lens of vertical sensors).

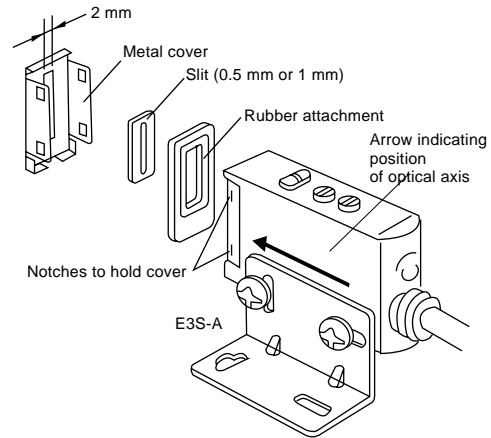

■ OPTICAL AXIS CONFIRMATION REFLECTOR E39-R5

Use this attachment when the set distance is long and adjustment is mechanically difficult with a sensing object.

Attach the reflector to the receiver (refer to the figure).

Look at the reflector from right behind the emitter. The reflector should be bright with red light when the optical beam strikes the reflector. If the emitter has a turbo function, the reflector looks brighter with the function switched on.

When the reflector is removed, the light beam strikes the receiver.

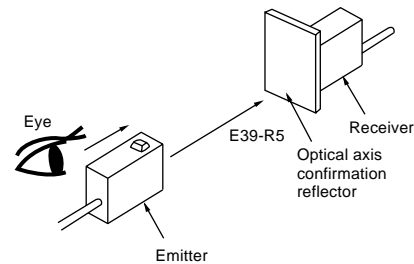

■ ADJUSTER CAP AND OPTIONAL E39-G2 SENSITIVITY ADJUSTER KNOB

Adjuster Cap (Supplied with each sensor)

In order to prevent the sensitivity or OFF-delay time that has been set from changing accidentally, cover the adjusters with the adjuster cap (enclosed).

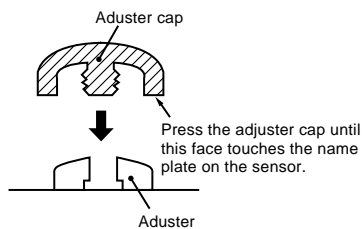

E39-G2 Adjuster Knob

To temporarily use the knob to adjust the sensitivity of the photoelectric sensor, insert side A into the shaft of the sensitivity adjuster. To snap the adjuster onto the sensor, push side B onto the sensitivity knob.

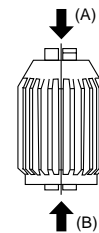

■ E39-E6 MUTUAL INTERFERENCE FILTER

A set of 4 filters are sold together for two through-beam models (for 2 each of emitters and receivers).

The arrow printed on the cover indicates the direction of polarization. By attaching the filters opposite to each other in polarization to the emitters and the receivers (refer to the figure) in rows, mutual interference can be prevented (in any case, the filter attached to an emitter and to the corresponding receiver must be the same in direction of polarization or the photoelectric sensor will not function).

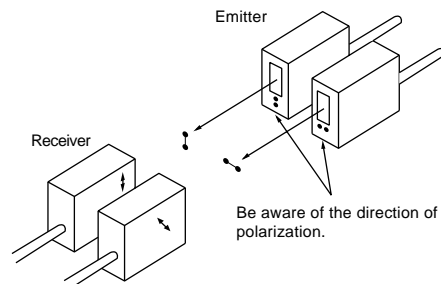



OMRON ELECTRONICS LLC.

One East Commerce Drive
Schaumburg, IL 60173

1-800-55-OMRON

OMRON ON-LINE

Global - <http://www.omron.com>
USA - <http://www.omron.com/oei>
Canada - <http://www.omron.com/oci>

OMRON CANADA, INC.

885 Milner Avenue
Scarborough, Ontario M1B 5V8

416-286-6465

Mouser Electronics

Authorized Distributor

Click to View Pricing, Inventory, Delivery & Lifecycle Information:

[Omron:](#)

[E39-R5](#)