

THIS DOCUMENT IS THE PROPERTY OF
KEYSTONE ELECTRONICS CORP. AND
SHALL NOT BE REPRODUCED, DISTRIBUTED
OR USED AS A BASIS FOR MANUFACTURE
WITHOUT PRIOR WRITTEN PERMISSION
FROM KEYSTONE ELECTRONICS CORP.

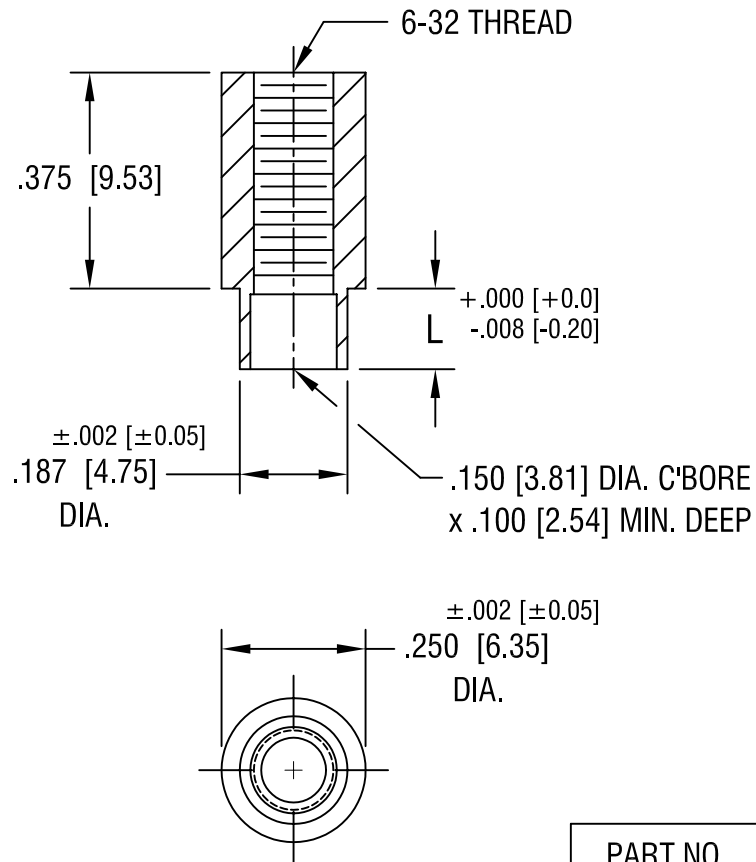

| PART NO. | 'L' DIM. |
|----------|-------------|
| 1561B | .109 [2.77] |
| 1561C | .140 [3.56] |
| 1561D | .171 [4.34] |

KEYSTONE ELECTRONICS CORP.

ASTORIA, N.Y. 11105-2017

PART NAME

SWAGE THREADED STANDOFF

MATERIAL

BRASS

FINISH

DUCTILE
NICKEL PLATE

DRN BY

BOONE

DATE

5.14.02

APPD

LN

SCALE

3X

TOLERANCES

INCH [MM]

DECIMAL ±.005 [±0.15]

ANGULAR ± 1°

UNLESS OTHERWISE SPECIFIED

CODE

C/M

DWG NO.

1561-

DATE

DESCRIPTION

REV.

Mouser Electronics

Authorized Distributor

Click to View Pricing, Inventory, Delivery & Lifecycle Information:

[Keystone Electronics:](#)

[1561C](#)