

THIS DRAWING IS UNPUBLISHED. RELEASED FOR PUBLICATION
 © COPYRIGHT - By - ALL RIGHTS RESERVED.

LOC	DIST	REVISIONS					
		P	LTR	DESCRIPTION	DATE	DWN	APVD
			F1	NEW DRAWING PER ECO-11-019045	09APR12	KH	DR

AMP WIRE RANGE	 Listed FILE E13288
12-10 AWG SOLID OR STRANDED	12-10 AWG SOLID OR STRANDED

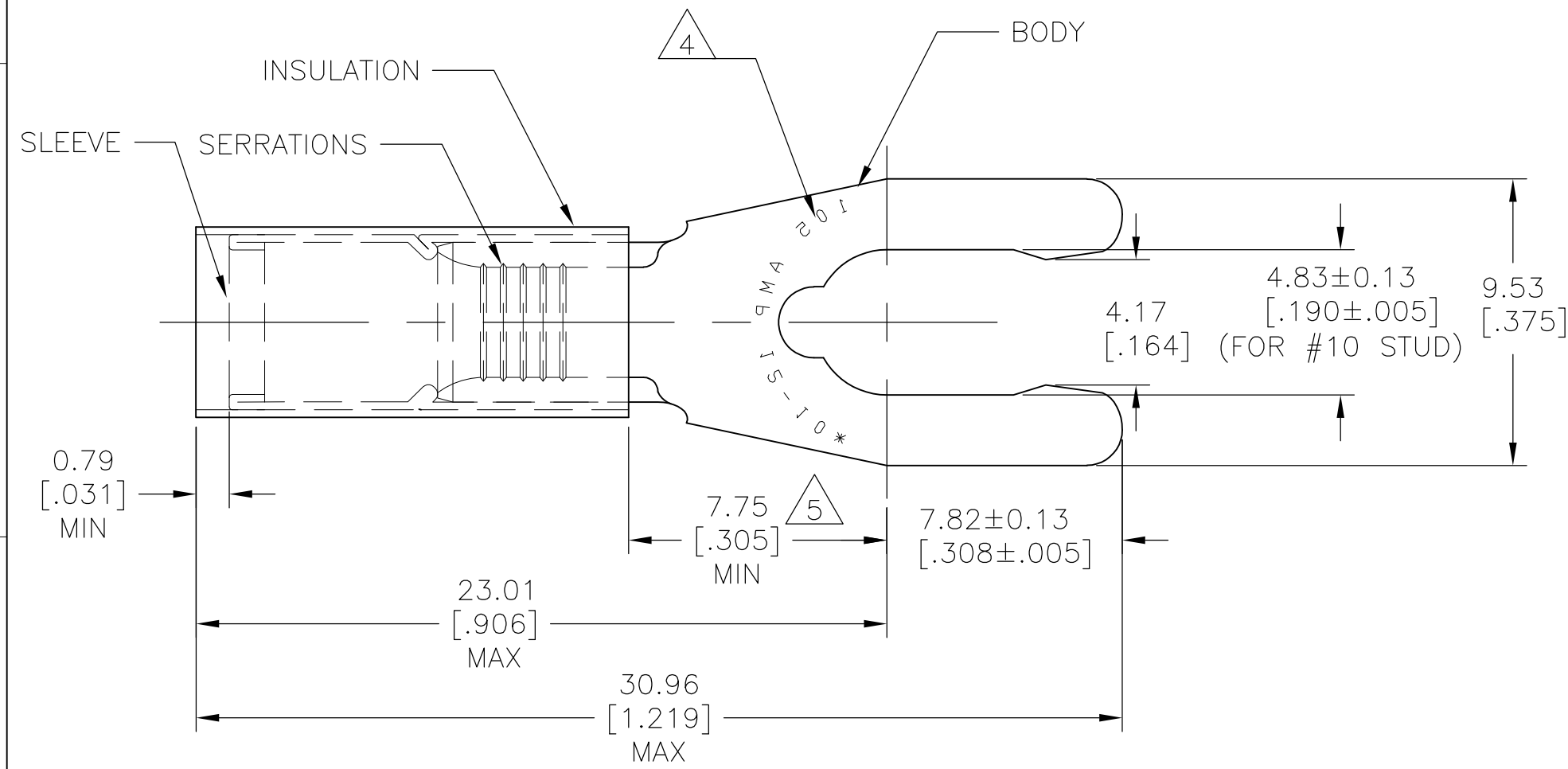

- 1 FOR WIRE INSULATION DIA:
3.81[.150] TO 6.35[.250]
- 2 FOR WIRE INSULATION DIA:
3.81[.150] TO 5.84[.230]
- 3 TONGUE MATERIAL THK: 0.98±0.05[.0385±.0020]
- 4 STAMP 105 AMP 12-10* APPROX AS SHOWN
- 5 DIMENSION APPLIES FROM EDGE OF METAL
WIRE BARREL TO CENTER OF STUD.
- 6 MATERIAL:
BODY: PHOSPHOR BRONZE PER ASTM B139
SLEEVE: COPPER PER ASTM B152
INSULATION: NYLON.
- 7 FINISH:
BODY&SLEEVE: TIN PLATE PER ASTM B545
INSULATION: COLOR-YELLOW

1	2500	ON TAPE REEL	52432-3
2	2500	ON TAPE REEL	52432-2
1	500	LOOSE PIECE	52432-1
	QTY	PACKAGE TYPE	PART NO

AMP INCORPORATED
CUSTOMER SERVICE SYSTEMS

FOR ADDITIONAL PRODUCT INFORMATION OR COPIES OF DRAWINGS AND TECHNICAL DOCUMENTS
 PRODUCT INFORMATION CENTER
 1-800-522-6752

FOR APPLICATION TOOLING INFORMATION
 TOOLING ASSISTANCE CENTER
 1-800-722-1111

FOR ORDER ENTRY
 1-800-526-5142

RECOMMENDED OPERATING TEMPERATURE:
 105°C [221°F]

VOLTAGE RATING:
 300V MAX

WIRE CROSS SECTIONAL AREA RANGE:
 2.62-6.64mm² [5,180-13,100]
 SOLID OR STRANDED

THIS DRAWING IS A CONTROLLED DOCUMENT.

DIMENSIONS:
mm [INCHES]

TOLERANCES UNLESS OTHERWISE SPECIFIED:

0 PLC	± -
1 PLC	± -
2 PLC	± 0.203[.008]
3 PLC	± -
4 PLC	± -
ANGLES	± 5°

MATERIAL 

FINISH 

DWN KIRAN HOLAL 27MAR12	 TE Connectivity		
CHK ROHDE DANIEL 27MAR12			
APVD ROHDE DANIEL 27MAR12	NAME		
PRODUCT SPEC	WIRE TERMINAL P.I.D.G SPRING SPADE WIRE SIZE: 12-10		
APPLICATION SPEC	SIZE	CAGE CODE	DRAWING NO
WEIGHT	A3	00779	C-52432
CUSTOMER DRAWING		SCALE	SHEET
		5:1	1 OF 1
		REV	F1

Mouser Electronics

Authorized Distributor

Click to View Pricing, Inventory, Delivery & Lifecycle Information:

[TE Connectivity:](#)

[52432-1](#)