

FEATURES:

- Enhanced N channel FET with no inherent diode to Vcc
- 5Ω bidirectional switches connect inputs to outputs
- Pin compatible with the 74F257, 74FCT257, and 74FCT257T
- Zero propagation delay, zero ground bounce
- Undershoot clamp diodes on all switch and control inputs
- TTL-compatible control inputs
- Available in QSOP and S1 packages

APPLICATIONS:

- Logic replacement
- Video, audio, graphics switching, muxing
- Hot-swapping, hot-docking
- Voltage translation (5V to 3.3V)
- Bus funneling

DESCRIPTION:

The QS3257 is a high-speed CMOS LVTTTL-compatible Quad 2:1 multiplexer/demultiplexer. The QS3257 is a function and pinout compatible QuickSwitch version of the 74F257, 74FCT257, and the 74ALS/AS/LS257 Quad 2:1 multiplexers. The low ON resistance of the QS3257 allows inputs to be connected to outputs without adding propagation delay and without generating additional ground bounce noise.

Mux/Demux devices provide an order of magnitude faster speed than equivalent logic devices.

The QS3257 is characterized for operation at -40°C to +85°C.

FUNCTIONAL BLOCK DIAGRAM

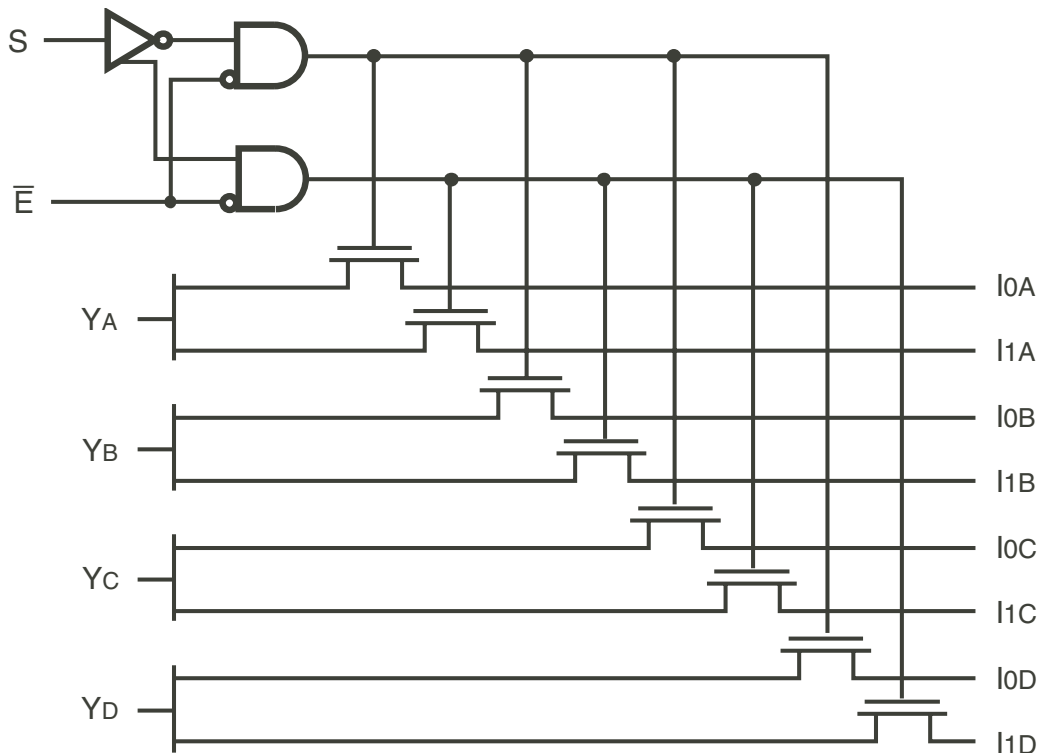

PIN CONFIGURATION

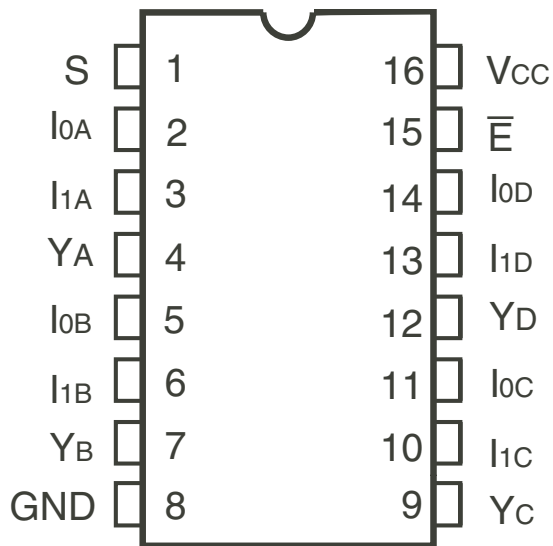

QSOP/ S1
TOP VIEW

ABSOLUTE MAXIMUM RATINGS⁽¹⁾

Symbol	Description	Max	Unit
VTERM ⁽²⁾	Supply Voltage to Ground	-0.5 to +7	V
VTERM ⁽³⁾	DC Switch Voltage Vs	-0.5 to +7	V
VTERM ⁽³⁾	DC Input Voltage VIN	-0.5 to +7	V
VAC	AC Input Voltage (pulse width ≤ 20ns)	-3	V
IOUT	DC Output Current	120	mA
PMAX	Maximum Power Dissipation (TA = 85°C)	0.5	W
TSTG	Storage Temperature	-65 to +150	°C

NOTE:

- Stresses greater than those listed under ABSOLUTE MAXIMUM RATINGS may cause permanent damage to the device. This is a stress rating only and functional operation of the device at these or any other conditions above those indicated in the operational sections of this specification is not implied. Exposure to absolute maximum rating conditions for extended periods may affect reliability.
- Vcc terminals.
- All terminals except Vcc.

CAPACITANCE

(TA = +25°C, f = 1.0MHz, VIN = 0V, VOUT = 0V)

Pins		Typ.	Max. ⁽¹⁾	Unit
Control Pins		4	5	pF
Quickswitch Channels (Switch OFF)	Demux	5	7	pF
	Mux	8	9	

NOTE:

- This parameter is measured at characterization but not tested.

PIN DESCRIPTION

Pin Names	I/O	Description
Ixx	I	Data Inputs
S	I	Select Input
E-bar	I	Enable Input
YA - YD	O	Data Outputs

FUNCTION TABLE⁽¹⁾

Enable		Outputs				Function
E-bar	S	YA	YB	YC	YD	
H	X	Hi-Z	Hi-Z	Hi-Z	Hi-Z	Disconnected
L	L	I0A	I0B	I0C	I0D	Select 0
L	H	I1A	I1B	I1C	I1D	Select 1

NOTE:

- H = HIGH Voltage Level
L = LOW Voltage Level
X = Don't Care
Z = High-Impedance

DC ELECTRICAL CHARACTERISTICS OVER OPERATING RANGE

Following Conditions Apply Unless Otherwise Specified:

Industrial: $T_A = -40^{\circ}\text{C}$ to $+85^{\circ}\text{C}$, $V_{CC} = 5.0\text{V} \pm 5\%$

Symbol	Parameter	Test Conditions	Min.	Typ. ⁽¹⁾	Max.	Unit
V_{IH}	Input HIGH Level	Guaranteed Logic HIGH for Control Pins	2	—	—	V
V_{IL}	Input LOW Level	Guaranteed Logic LOW for Control Pins	—	—	0.8	V
I_{IN}	Input Leakage Current (Control Inputs) ⁽²⁾	$0\text{V} \leq V_{IN} \leq V_{CC}$	—	—	± 1	μA
I_{OZ}	Off-State Output Current (Hi-Z)	$0\text{V} \leq V_{OUT} \leq V_{CC}$	—	—	± 1	μA
RON	Switch ON Resistance	$V_{CC} = \text{Min.}, V_{IN} = 0\text{V}, I_{ON} = 30\text{mA}$	—	5	7	Ω
		$V_{CC} = \text{Min.}, V_{IN} = 2.4\text{V}, I_{ON} = 15\text{mA}$	—	10	15	
VP	Pass Voltage ⁽²⁾	$V_{IN} = V_{CC} = 5\text{V}, I_{OUT} = -5\mu\text{A}$	3.7	4	4.2	V

NOTES:

1. Typical values are at $V_{CC} = 5.0\text{V}$, $T_A = 25^{\circ}\text{C}$.
2. Pass Voltage is guaranteed but not production tested.

TYPICAL ON RESISTANCE vs VIN AT VCC = 5V

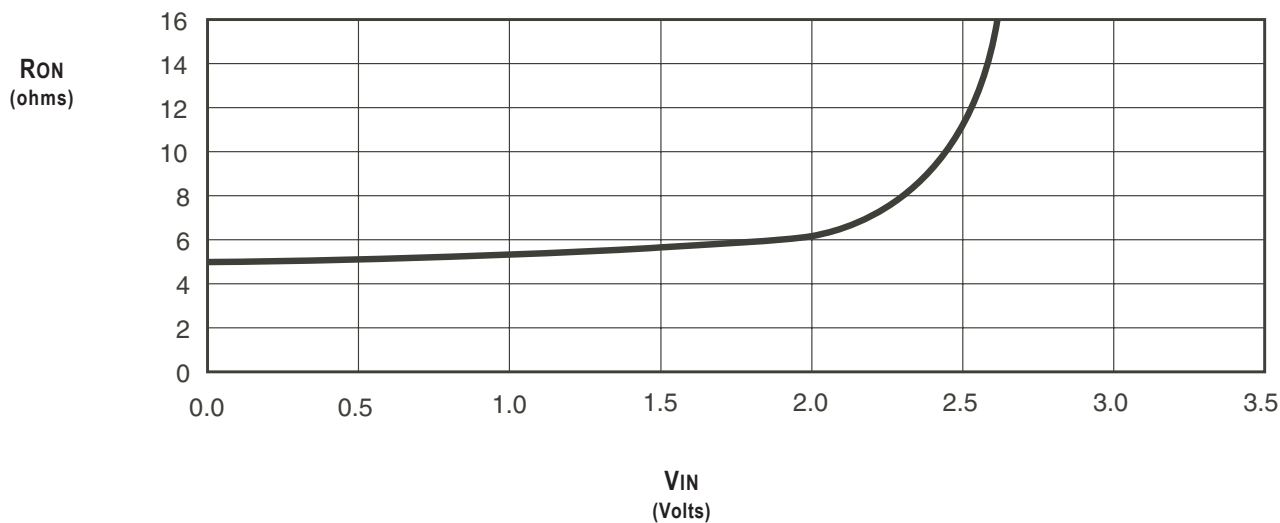

POWER SUPPLY CHARACTERISTICS

Symbol	Parameter	Test Conditions ⁽¹⁾	Max.	Unit
I _{CCQ}	Quiescent Power Supply Current	V _{CC} = Max., V _{IN} = GND or V _{CC} , f = 0	3	μA
ΔI _{CC}	Power Supply Current per Control Input HIGH ⁽²⁾	V _{CC} = Max., V _{IN} = 3.4V, f = 0	1.5	mA
I _{CCD}	Dynamic Power Supply Current per MHz ⁽³⁾	V _{CC} = Max., I and Y pins open Control Inputs Toggling at 50% Duty Cycle	0.25	mA/MHz

NOTES:

- For conditions shown as Min. or Max., use the appropriate values specified under DC Electrical Characteristics.
- Per TLL driven input (V_{IN} = 3.4V, control inputs only). I and Y pins do not contribute to ΔI_{CC}.
- This current applies to the control inputs only and represents the current required to switch internal capacitance at the specified frequency. The I and Y inputs generate no significant AC or DC currents as they transition. This parameter is guaranteed but not production tested.

SWITCHING CHARACTERISTICS OVER OPERATING RANGE

T_A = -40°C to +85°C, V_{CC} = 5.0V ± 5%;

C_{LOAD} = 50pF, R_{LOAD} = 500Ω unless otherwise noted.

Symbol	Parameter	Min. ⁽¹⁾	Typ.	Max.	Unit
t _{PLH}	Data Propagation Delay ^(2,3)	—	—	0.25 ⁽³⁾	ns
t _{PHL}	I _x to Y				
t _{PZH}	Switch Turn-on Delay	0.5	—	5.2	ns
t _{PZL}	S _x to Y				
t _{PZH}	Switch Turn-on Delay	0.5	—	4.8	ns
t _{PZL}	\bar{E}_x to Y				
t _{PHZ}	Switch Turn-off Delay ⁽²⁾	0.5	—	5	ns
t _{PLZ}	\bar{E}_x to Y, S _x to Y				

NOTES:

- Minimums are guaranteed but not production tested.
- This parameter is guaranteed but not production tested.
- The bus switch contributes no propagation delay other than the RC delay of the ON resistance of the switch and the load capacitance. The time constant for the switch alone is of the order of 0.25ns for C_L = 50pF. Since this time constant is much smaller than the rise and fall times of typical driving signals, it adds very little propagation delay to the system. Propagation delay of the bus switch, when used in a system, is determined by the driving circuit on the driving side of the switch and its interaction with the load on the driven side.

ORDERING INFORMATION

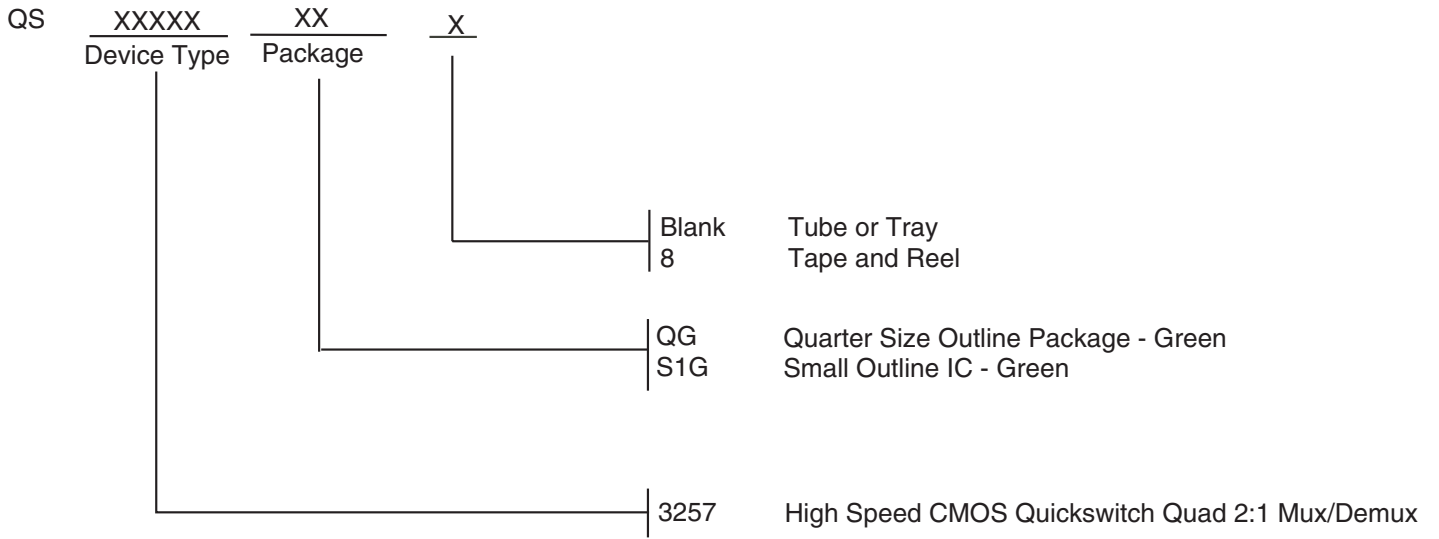

Datasheet Document History

02/14/2011 Pg. 5 Updated the ordering information by removing the "IDT" notation, non RoHS part and by adding Tape and Reel information.

Notice

1. Descriptions of circuits, software and other related information in this document are provided only to illustrate the operation of semiconductor products and application examples. You are fully responsible for the incorporation or any other use of the circuits, software, and information in the design of your product or system. Renesas Electronics disclaims any and all liability for any losses and damages incurred by you or third parties arising from the use of these circuits, software, or information.
2. Renesas Electronics hereby expressly disclaims any warranties against and liability for infringement or any other claims involving patents, copyrights, or other intellectual property rights of third parties, by or arising from the use of Renesas Electronics products or technical information described in this document, including but not limited to, the product data, drawings, charts, programs, algorithms, and application examples.
3. No license, express, implied or otherwise, is granted hereby under any patents, copyrights or other intellectual property rights of Renesas Electronics or others.
4. You shall not alter, modify, copy, or reverse engineer any Renesas Electronics product, whether in whole or in part. Renesas Electronics disclaims any and all liability for any losses or damages incurred by you or third parties arising from such alteration, modification, copying or reverse engineering.
5. Renesas Electronics products are classified according to the following two quality grades: "Standard" and "High Quality". The intended applications for each Renesas Electronics product depends on the product's quality grade, as indicated below.
 - "Standard": Computers; office equipment; communications equipment; test and measurement equipment; audio and visual equipment; home electronic appliances; machine tools; personal electronic equipment; industrial robots; etc.
 - "High Quality": Transportation equipment (automobiles, trains, ships, etc.); traffic control (traffic lights); large-scale communication equipment; key financial terminal systems; safety control equipment; etc.Unless expressly designated as a high reliability product or a product for harsh environments in a Renesas Electronics data sheet or other Renesas Electronics document, Renesas Electronics products are not intended or authorized for use in products or systems that may pose a direct threat to human life or bodily injury (artificial life support devices or systems; surgical implantations; etc.), or may cause serious property damage (space system; undersea repeaters; nuclear power control systems; aircraft control systems; key plant systems; military equipment; etc.). Renesas Electronics disclaims any and all liability for any damages or losses incurred by you or any third parties arising from the use of any Renesas Electronics product that is inconsistent with any Renesas Electronics data sheet, user's manual or other Renesas Electronics document.
6. When using Renesas Electronics products, refer to the latest product information (data sheets, user's manuals, application notes, "General Notes for Handling and Using Semiconductor Devices" in the reliability handbook, etc.), and ensure that usage conditions are within the ranges specified by Renesas Electronics with respect to maximum ratings, operating power supply voltage range, heat dissipation characteristics, installation, etc. Renesas Electronics disclaims any and all liability for any malfunctions, failure or accident arising out of the use of Renesas Electronics products outside of such specified ranges.
7. Although Renesas Electronics endeavors to improve the quality and reliability of Renesas Electronics products, semiconductor products have specific characteristics, such as the occurrence of failure at a certain rate and malfunctions under certain use conditions. Unless designated as a high reliability product or a product for harsh environments in a Renesas Electronics data sheet or other Renesas Electronics document, Renesas Electronics products are not subject to radiation resistance design. You are responsible for implementing safety measures to guard against the possibility of bodily injury, injury or damage caused by fire, and/or danger to the public in the event of a failure or malfunction of Renesas Electronics products, such as safety design for hardware and software, including but not limited to redundancy, fire control and malfunction prevention, appropriate treatment for aging degradation or any other appropriate measures. Because the evaluation of microcomputer software alone is very difficult and impractical, you are responsible for evaluating the safety of the final products or systems manufactured by you.
8. Please contact a Renesas Electronics sales office for details as to environmental matters such as the environmental compatibility of each Renesas Electronics product. You are responsible for carefully and sufficiently investigating applicable laws and regulations that regulate the inclusion or use of controlled substances, including without limitation, the EU RoHS Directive, and using Renesas Electronics products in compliance with all these applicable laws and regulations. Renesas Electronics disclaims any and all liability for damages or losses occurring as a result of your noncompliance with applicable laws and regulations.
9. Renesas Electronics products and technologies shall not be used for or incorporated into any products or systems whose manufacture, use, or sale is prohibited under any applicable domestic or foreign laws or regulations. You shall comply with any applicable export control laws and regulations promulgated and administered by the governments of any countries asserting jurisdiction over the parties or transactions.
10. It is the responsibility of the buyer or distributor of Renesas Electronics products, or any other party who distributes, disposes of, or otherwise sells or transfers the product to a third party, to notify such third party in advance of the contents and conditions set forth in this document.
11. This document shall not be reprinted, reproduced or duplicated in any form, in whole or in part, without prior written consent of Renesas Electronics.
12. Please contact a Renesas Electronics sales office if you have any questions regarding the information contained in this document or Renesas Electronics products.

(Note1) "Renesas Electronics" as used in this document means Renesas Electronics Corporation and also includes its directly or indirectly controlled subsidiaries.

(Note2) "Renesas Electronics product(s)" means any product developed or manufactured by or for Renesas Electronics.

(Rev.4.0-1 November 2017)

Corporate Headquarters

TOYOSU FORESIA, 3-2-24 Toyosu,
Koto-ku, Tokyo 135-0061, Japan
www.renesas.com

Contact Information

For further information on a product, technology, the most up-to-date version of a document, or your nearest sales office, please visit:
www.renesas.com/contact/

Trademarks

Renesas and the Renesas logo are trademarks of Renesas Electronics Corporation. All trademarks and registered trademarks are the property of their respective owners.