

D-SUB connector set - VS-25-SET-EMV - 1652208

Please be informed that the data shown in this PDF Document is generated from our Online Catalog. Please find the complete data in the user's documentation. Our General Terms of Use for Downloads are valid (<http://phoenixcontact.com/download>)



D-SUB connector set, shell size 3, IP67 protection, with shrouds

The illustration shows the version VS-09-SET-EMV



Key Commercial Data

| | |
|--------------------------------------|----------|
| Packing unit | 1 pc |
| Weight per Piece (excluding packing) | 113.8 g |
| Custom tariff number | 85366990 |
| Country of origin | Germany |

Technical data

Environmental Product Compliance

| | |
|------------|---------------|
| REACH SVHC | DEHP 117-81-7 |
|------------|---------------|

Mechanical characteristics

| | |
|-----------------------------|---------------|
| Number of positions | 25 |
| Shielded | yes |
| Insertion/withdrawal cycles | ≥ 1000 |
| External cable diameter | 3 mm ... 9 mm |
| Cable exit | Angled |
| Type of cable | Round cable |
| Color | gray |

Ambient conditions

| | |
|---------------------------------|------------------|
| Ambient temperature (operation) | -40 °C ... 80 °C |
|---------------------------------|------------------|

Material data

| | |
|--|----|
| Flammability rating according to UL 94 | V0 |
|--|----|

D-SUB connector set - VS-25-SET-EMV - 1652208

Technical data

Material data

| | |
|---------------------|--|
| Housing material | PA |
| Sealing material | Flat gasket: NBR; profile gasket: EPDM |
| Seal material | Flat gasket: NBR; profile gasket: EPDM |
| Cable seal material | CR/NBR |

Electrical characteristics

| | |
|---------------------|----|
| Number of positions | 25 |
| Degree of pollution | 2 |

Standards and Regulations

| | |
|--|----|
| Flammability rating according to UL 94 | V0 |
|--|----|

Classifications

eCl@ss

| | |
|------------|----------|
| eCl@ss 4.0 | 27140816 |
| eCl@ss 4.1 | 27260701 |
| eCl@ss 5.0 | 27260701 |
| eCl@ss 5.1 | 27260701 |
| eCl@ss 6.0 | 27260705 |
| eCl@ss 7.0 | 27440309 |
| eCl@ss 8.0 | 27440302 |
| eCl@ss 9.0 | 27440302 |

ETIM

| | |
|----------|----------|
| ETIM 2.0 | EC001121 |
| ETIM 3.0 | EC001132 |
| ETIM 4.0 | EC001132 |
| ETIM 5.0 | EC001132 |

UNSPSC

| | |
|---------------|----------|
| UNSPSC 6.01 | 31261501 |
| UNSPSC 7.0901 | 31261501 |
| UNSPSC 11 | 31261501 |
| UNSPSC 12.01 | 31261501 |
| UNSPSC 13.2 | 31261501 |

Approvals

Approvals

D-SUB connector set - VS-25-SET-EMV - 1652208

Approvals

Approvals

EAC / EAC / EAC

Ex Approvals

Approvals submitted

Approval details

| |
|-----|
| EAC |
| EAC |
| EAC |

Drawings

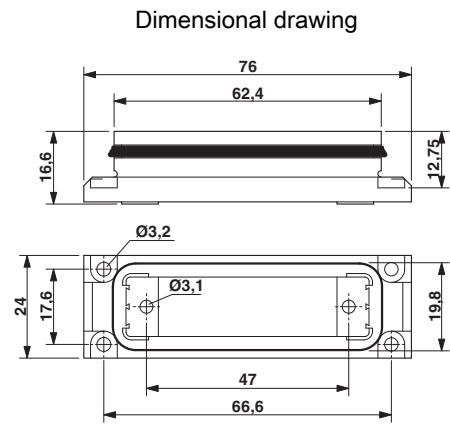
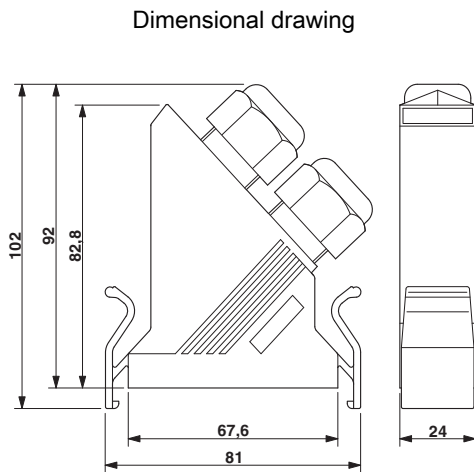

D-SUB panel mounting frame

D-SUB sleeve housings

D-SUB connector set - VS-25-SET-EMV - 1652208

Dimensional drawing

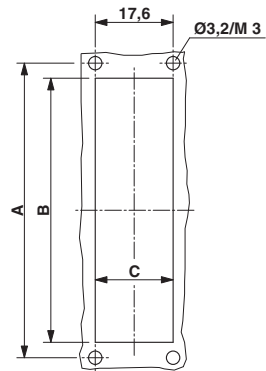

Panel cutout

Phoenix Contact 2016 © - all rights reserved
<http://www.phoenixcontact.com>

Mouser Electronics

Authorized Distributor

Click to View Pricing, Inventory, Delivery & Lifecycle Information:

[Phoenix Contact:](#)

[1652208](#)