

ALTERNATE CONSTRUCTION

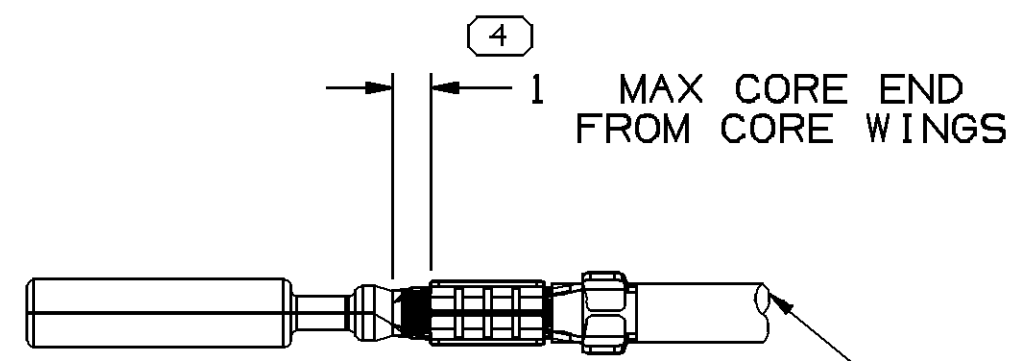

5 TERMINAL MUST FIT A MAX Ø 2.1 MM GAGE (GB869-06A) HOLE 17 MM DEEP AFTER CRIMPING
 OPTIONAL CONSTRUCTION:
 TERMINAL MUST FIT A MAX Ø 2.4 MM GAGE (#TBD) HOLE 17 MM DEEP AFTER CRIMPING (SEE NOTE #4)

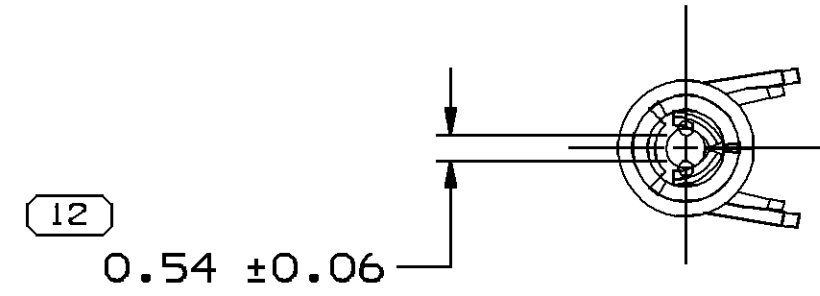
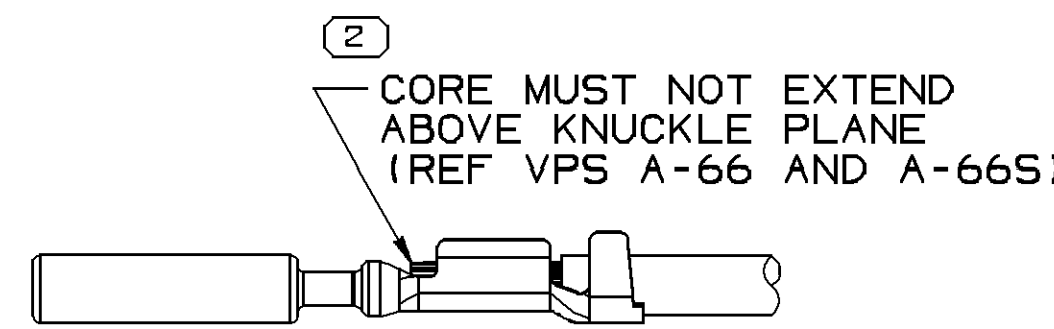

CRIMP STRAIGHTNESS AND CORE RESTRICTIONS

SEE P/N BLOCK FOR COMPLETE CABLE DIAMETER RANGE

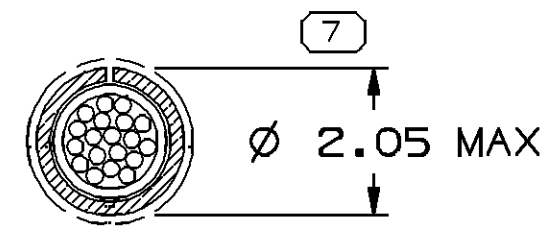

MAXIMUM INSULATION CRIMP DIMENSIONS

MAXIMUM CABLE INSULATION DIAMETER TO BE USED IS 1.9 MM REF ES-M-3292 OR EQUIVALENT SPECIFICATION

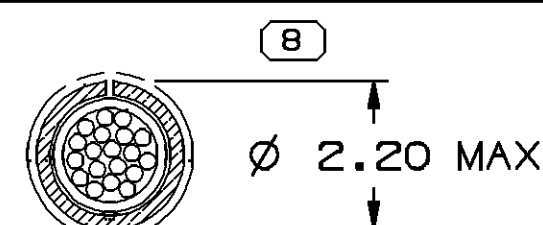

OPTIONAL CONSTRUCTION: MAXIMUM CABLE INSULATION DIAMETER TO BE USED IS 2.20 mm (0.5 mm² CORE) (SEE NOTE #4)

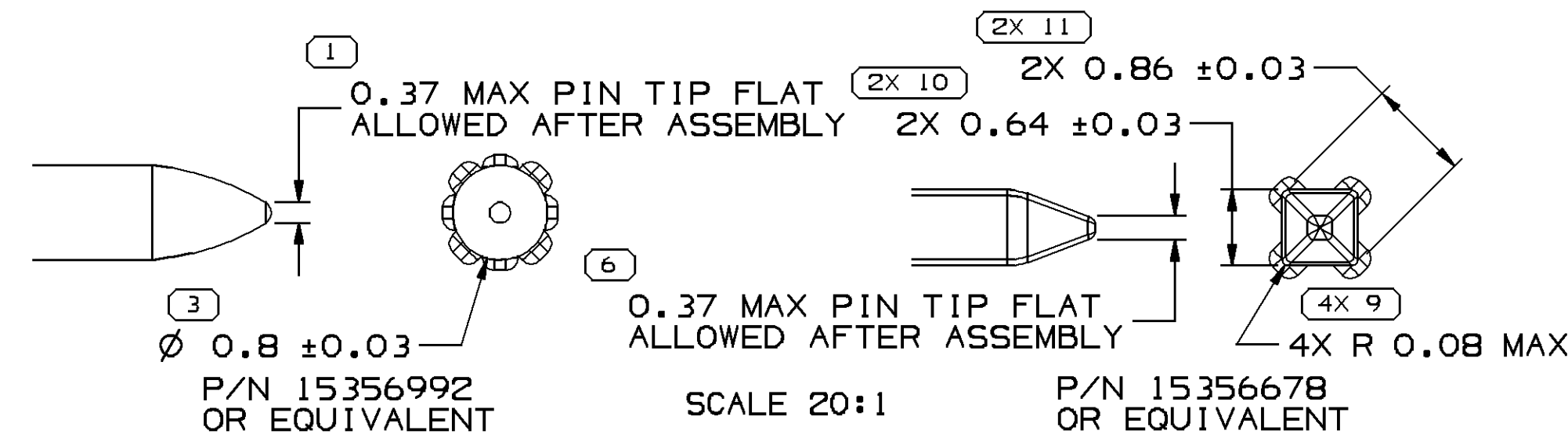

MATING PIN DESIGNS

REFER TO SPECIFIC PIN DRAWINGS FOR COMPLETE REQUIREMENTS (I.E. MATERIAL, PLATING DIMENSIONS, ETC)

INSPECTION SYMBOLS SHOWN IN THESE VIEWS ARE FOR REFERENCE ONLY

SYMBOL DEFINITION

A DIMENSION WITHOUT AN INSPECTION REPORT SYMBOL DOES NOT REQUIRE INSPECTION. IT MAY BE CONTROLLED ON THE INDIVIDUAL COMPONENT DRAWING.

TOTAL NO OF INSPECTIONS REQUIRED	27
LAST NO. USED	19

MISSING SYMBOLS

NO MISSING SYMBOL NUMBER

DWG STATUS		ZONE	REVISION HISTORY		AUTH	DR	APVD1	APVD2
DATE	STG	REV	N/P	CHG				
03MY00	R	001	-	-				
19SE00	R	002	-	-				
06N000	R	003	-	-				
18JA01	R	004	-	-				
23JA01	R	005	-	-				
23JA01	R	006	-	-				
30AP01	R	007	-	-				
28SE01	R	008	-	-				
24JL02	R	09	-	-				
31JA03	R	10	-	-				
23JA03	R	11	-	-				
30JA04	R	12	-	-				
04MR04	R	13	-	-				
01JL04	R	14	-	-				
14JA05	R	15	-	-				
01DE05	R	16	-	-				
02MR06	R	17	-	-				
06FE07	R	18	-	-				

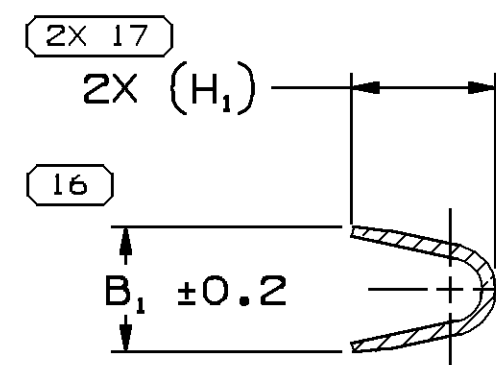
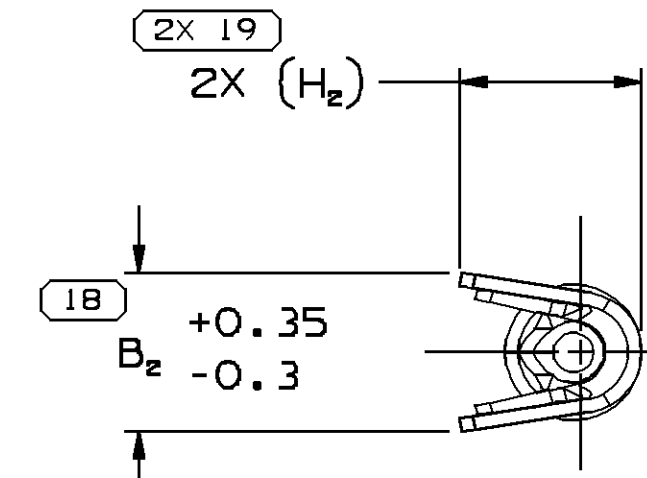
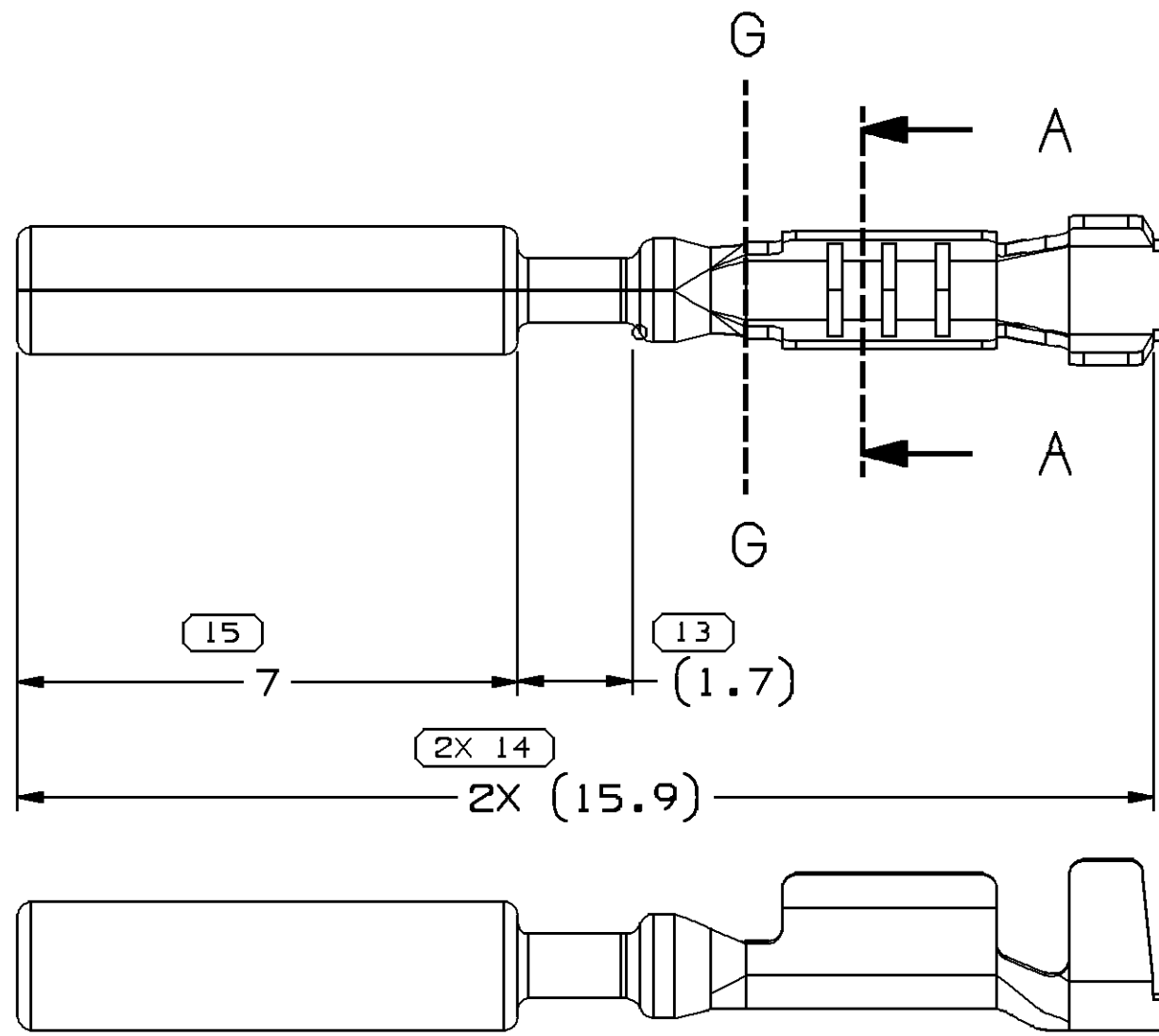

SECTION A-A TO G-G

VIEW SCALE DOES NOT REFLECT ACTUAL PART SIZE

NOTES

- UNLESS OTHERWISE SPECIFIED AND/OR INDICATED: DIMENSIONS ARE TO FACE OF VIEW SHOWN AND AUTOMATICALLY ROUNDED BY COMPUTER FOR INSPECTION. (SEE MATH MODEL FOR PRECISE DIMENSIONS.) FOR ALL OTHER DIMENSIONS NOT SHOWN BUT REQUIRED FOR TOOL BUILD, SEE MATH MODEL FOR PRECISE TOOL PATH DATA.
- MAXIMUM CURRENT CAPACITY IS 7 AMPS.
- MATING COMPONENTS: CONNECTOR 15356814 OR EQUIVALENT PIN (SEE MATING PIN DESIGN VIEWS)
- TERMINAL 15356827 MAY BE USED WITH 0.5 mm² CABLE UP TO 2.19 MAX O.D. THIS IS A SPECIAL APPLICATION WHERE CONNECTOR CAVITIES ARE AT 3.0 MIN NOMINAL SPACING (REFERENCE CONNECTOR ASSEMBLY PE123151 OR EQUIVALENT)

PART NO	REV	N/P	STATUS	MAT'L SIZE	MAT'L SPEC (PLATING)	SIZE (MM ²)	ID	CABLE DIA	B ₁ ± 0.2	B ₂ +0.35 -0.3	(H ₁)	(H ₂)
13576051	01	-		0.1778 X 30.48	M-1628-924 (TIN)	0.22	24	1.1-1.3	1.4	1.7	1.5	1.6
15359541	02	AF		0.1778 X 30.48	M-3696-FN1 (GOLD)	0.5-0.8	19	1.9-1.64	2.08	2.5	2.4	2.5
15401440	03	AK		0.1778 X 30.48	M-1628-924 (TIN)	0.5-0.8	19	1.9-1.64	2.08	2.5	2.4	2.5
15394147	03	AJ		0.1778 X 30.48	M-1628-924 (TIN)	0.35	22	1.63-1.47	1.65	2.1	1.9	2.4
15356827	04	AG		0.1778 X 30.48	M-3696-DN2 (GOLD)	0.5-0.8	19	1.9-1.64 SEE NOTE #4	2.08	2.5	2.4	2.5
15356826	04	AG		0.1778 X 30.48	M-3696-DN2 (GOLD)	0.35	22	1.63-1.47	1.65	2.1	1.9	2.4

(15) PROCESS SENSITIVE DIMENSION
DIMENSIONS ENCLOSED IN () INDICATE REFERENCE DIMENSIONS AND NO TOLERANCE LIMITS ARE ESTABLISHED
FROM TO 0 12 > 12
CHART D
TOLERANCE UNLESS OTHERWISE SPECIFIED ±0.1 ±0.2
ANGULAR TOLERANCE ±2°

DWG TYPE PART DRAWING

STYLE

VOLUME (CPI) DISTR CODE D

UNLESS OTHERWISE SPECIFIED THIS DOCUMENT IS IN ACCORDANCE WITH ASME Y14.5M-1994 AS AMENDED BY THE 2001 GLOBAL DIMENSIONING AND TOLERANCING ADDENDUM-2001. SEPARATE PATTERNS OF FEATURES MAY BE GAGED SEPARATELY REGARDLESS OF DATUM REFERENCES.

ALL DIMENSIONS ARE IN MILLIMETERS

REFERENCE

THIRD ANGLE PROJECTION

DO NOT SCALE USE MATH DATA

UNIGRAPHICS

DELPHI

DELPHI PACKARD ELECTRIC SYSTEMS WARREN, OH

DR	DATE
APVD1 LUIS ORDUNA A.	03MY00
APVD2 P. H. CASTRILLON	04MY00
APVD3 K. GRZENA	26MY00
APVD4	
APVD5	

SUBSTANCES OF CONCERN AND RECYCLED CONTENT PER DELPHI 10945001

MATERIAL SEE CHART

DRAWING NAME TAXI TERM F MICRO 64

DRAWING NUMBER 15356828

SIZE A1	SCALE 10:1	FRAME NO 1 OF 1	SHEET NO 1 OF 2	STG R	REV 18	N/P -
---------	------------	-----------------	-----------------	-------	--------	-------

Mouser Electronics

Authorized Distributor

Click to View Pricing, Inventory, Delivery & Lifecycle Information:

[Aptiv:](#)

[15356826-L](#) [15394147-L](#) [15401440-L](#) [15356827-L](#)