



Ø 172×150×51 mm

San Ace 172W 9WG type

Sidecut type

General Specifications

- Material Frame: Aluminum (Black coating), Impeller: Plastic (Flammability: UL 94V-1)
- Expected life See the table below. (L10 life: 90% survival rate for continuous operation in indoor free air at 60°C, rated voltage)
- Motor protection function Locked rotor burnout protection, Reverse polarity protection
For details, please refer to p. 529.
- Dielectric strength 50/60 Hz, 500 VAC, for 1 minute (between lead wire conductors and frame)
- Insulation resistance 10 MΩ or more with a 500 VDC megger (between lead wire conductors and frame)
- Sound pressure level (SPL) At 1 m away from the air inlet
- Storage temperature -30 to +70°C (Non-condensing)
- Lead wire ⊕Red ⊖Black (Sensor) Yellow (Control) Brown
- Mass 860 g
- Ingress protection IP68

Specifications

The models listed below **have pulse sensors with PWM control function.**

Model no.	Rated voltage [V]	Operating voltage range [V]	PWM duty cycle* [%]	Rated current [A]	Rated input [W]	Rated speed [min ⁻¹]	Max. airflow [m ³ /min] [CFM]	Max. static pressure [Pa] [inchH ₂ O]	SPL [dB (A)]	Operating temperature [°C]	Expected life [h]
9WG5748P5G001	48	40.8 to 55.2	100	2.91	140.0	8600	15.46 546	1000 4.02	78	-20 to +70	40000/60°C (70000/40°C)
			0	0.21	10.1	2000	3.59 127	75.1 0.3	40		
9WG5748P5H001			100	1.62	78.0	6500	11.6 410	770 3.09	71		
			0	0.21	10.1	2000	3.59 127	75.1 0.3	40		

* PWM frequency: 25 kHz

Other sensor specifications are available as options. Refer to the index (p. 559).

Airflow - Static Pressure Characteristics / PWM Duty - Speed Characteristics Example

9WG5748P5G001 With pulse sensor with PWM control function

PWM duty cycle

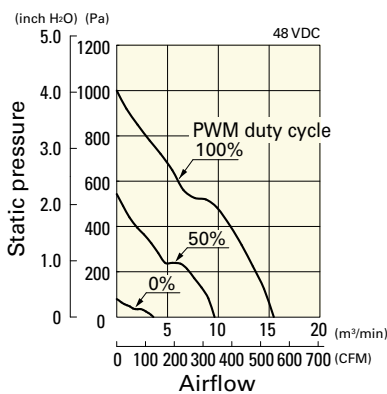

Operating voltage range

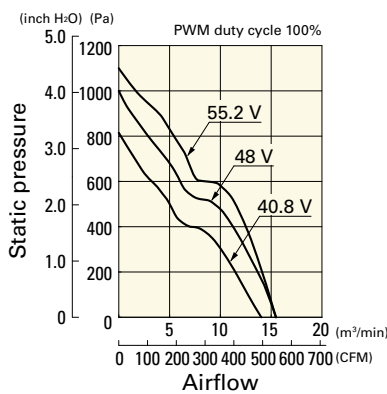

PWM duty - Speed characteristics example

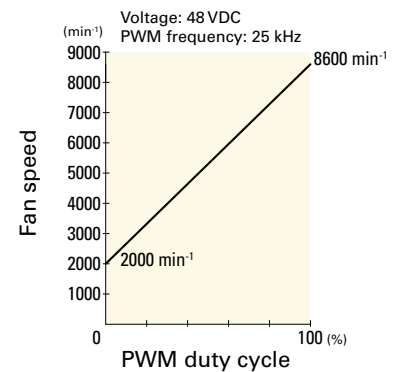

Airflow - Static Pressure Characteristics / PWM Duty - Speed Characteristics Example

9WG5748P5H001 With pulse sensor with PWM control function

PWM duty cycle

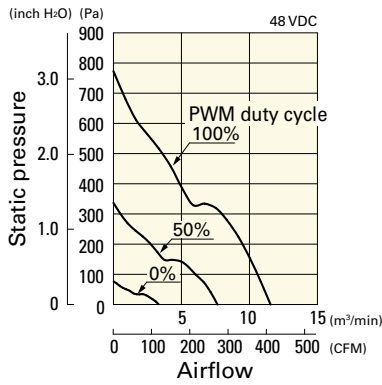

Operating voltage range

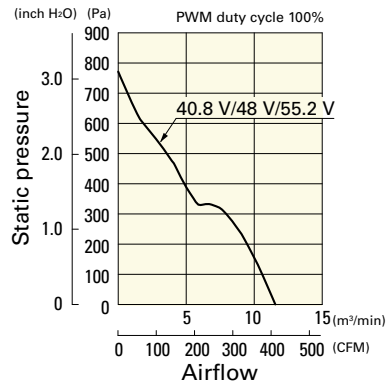

PWM duty - Speed characteristics example

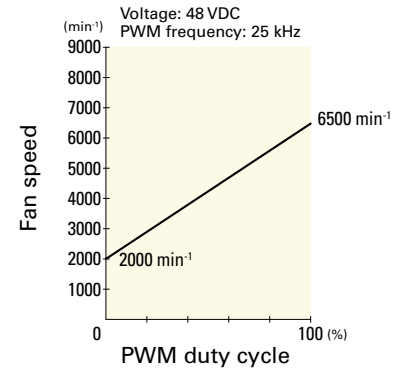

Dimensions (unit: mm)

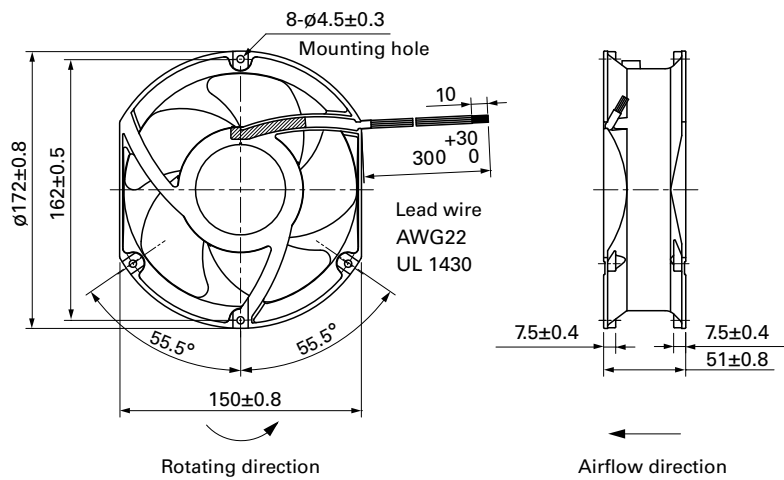

Reference Dimensions of Mounting Holes and Vent Opening (unit: mm)

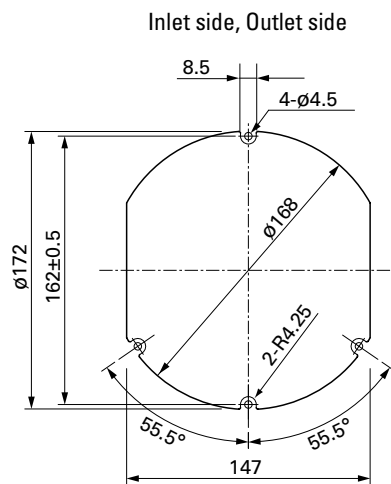

Options

Finger guards

page: p. 515

Model no.: 109-319J, 109-319E, 109-319H, 109-320



Ø 172×150×51 mm

San Ace 172W 9WE type   

Sidecut type

General Specifications

- Material Frame: Aluminum (Black coating), Impeller: Plastic (Flammability: UL 94V-1)
- Expected life See the table below. (L10 life: 90% survival rate for continuous operation in indoor free air at 60°C, rated voltage)
- Motor protection function Locked rotor burnout protection, Reverse polarity protection
For details, please refer to p. 529.
- Dielectric strength 50/60 Hz, 500 VAC, for 1 minute (between lead wire conductors and frame)
- Insulation resistance 10 MΩ or more with a 500 VDC megger (between lead wire conductors and frame)
- Sound pressure level (SPL) At 1 m away from the air inlet
- Storage temperature -30 to +70°C (Non-condensing)
- Lead wire ⊕Red ⊖Black or Blue (Sensor) Yellow
- Mass 860 g
- Ingress protection IP68

Specifications

The models listed below **have pulse sensors**.

Model no.	Rated voltage [V]	Operating voltage range [V]	Rated current [A]	Rated input [W]	Rated speed [min ⁻¹]	Max. airflow [m ³ /min] [CFM]	Max. static pressure [Pa] [inchH ₂ O]	SPL [dB (A)]	Operating temperature [°C]	Expected life [h]
9WE5724K501	24	20.4 to 27.6	1.3	31.2	4100	8.5 300	243 0.976	60	-20 to +60	40000/60°C
9WE5748K501	48	40.8 to 55.2	0.7	33.6	4100	8.5 300	243 0.976	60		

Other sensor specifications are available as options. Refer to the index (p. 558).

Airflow - Static Pressure Characteristics

9WE5724K501 With pulse sensor

Operating voltage range

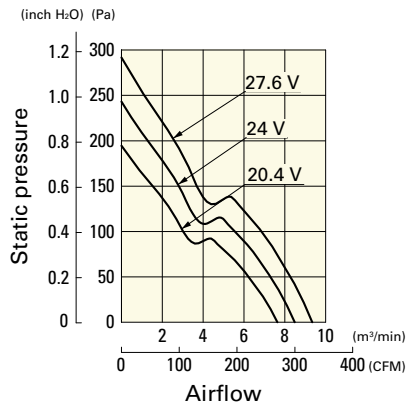

9WE5748K501 With pulse sensor

Operating voltage range

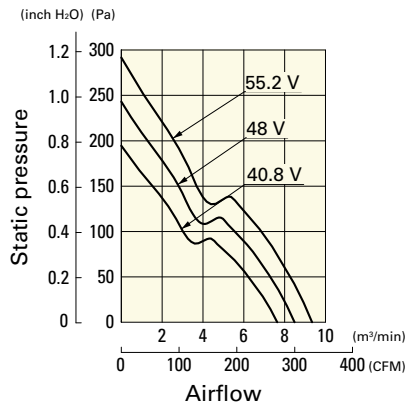

Dimensions (unit: mm)

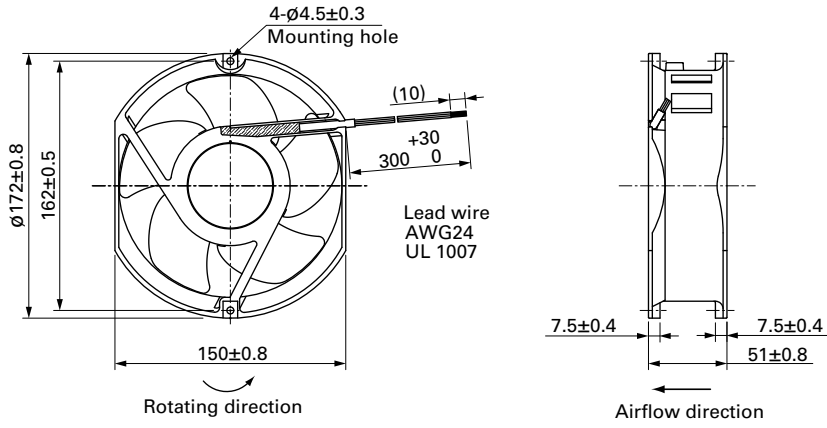

Reference Dimensions of Mounting Holes and Vent Opening (unit: mm)

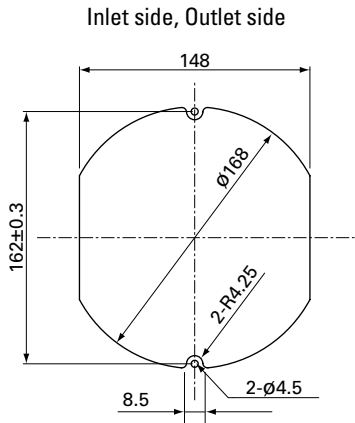

Options

Finger guards

page: p. 515

Model no.: 109-319E, 109-319H, 109-320

Mouser Electronics

Authorized Distributor

Click to View Pricing, Inventory, Delivery & Lifecycle Information:

[Sanyo Denki:](#)

[9WG5748P5G001](#) [9WG5748P5H001](#) [9WG5748G5002](#)