

DO NOT SCALE FROM THIS PRINT

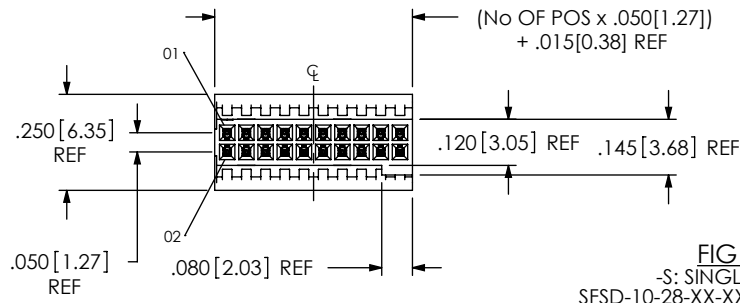

FEP CABLE OPTION  
-T: FEP (LEAVE BLANK FOR STANDARD PVC INSULATION)

No OF POSITIONS  
-02 THRU -50 (PER ROW)

WIRE GAUGE (AWG)  
-28, -30

COLOR CODE:

LEAVE BLANK FOR ALL BLACK WIRE  
C: COLOR CODED WIRE (SEE TABLE 4, SHT 3) (NOT AVAILABLE WITH FEP OPTION)

PLATING SPECIFICATION  
-H: 30μ" HEAVY GOLD IN CONTACT AREA, 3μ" GOLD ON TAIL  
-G: 10μ" LIGHT GOLD IN CONTACT AREA, 3μ" GOLD ON TAIL  
-F: 3μ" FLASH GOLD IN CONTACT AREA, 3μ" GOLD ON TAIL  
-GF: 3μ" FLASH SELECTIVE IN CONTACT AREA, 3μ" GOLD ON TAIL (ONLY AVAILABLE TO EXISTING CUSTOMERS; SEE -F PLATING) (SEE TABLE 3, SHEET 1)

ASSEMBLED LENGTH SPECIFY IN INCHES  
(SINGLE END: 03.00 INCH [76.2mm] MINIMUM)  
(DOUBLE END: 03.25 INCH [82.6mm] MINIMUM)

-NXX OPTION (END 2)  
(ONLY AVAILABLE WITH -D, -DL, -DR & -DS)  
-NUS: NOTCH UP, STRAIGHT (PIN 1 TO PIN N-1)  
-NDS: NOTCH DOWN, STRAIGHT (PIN 1 TO PIN 2)  
-NUX: NOTCH UP, CROSSED (PIN 1 TO PIN N)  
-NDX: NOTCH DOWN, CROSSED (PIN 1 TO PIN 1)

END OPTION (END OPTION COMBINATIONS NOT AVAILABLE)  
-S: SINGLE END  
-D: DOUBLE END (MUST CHOOSE FROM -NXX OPTIONS)  
-SL: SINGLE ENDED WITH FRICTION LOCK (SEE SHEET 2, FIG 3) (ONLY AVAILABLE ON \*5,\*7, 10 THRU 50 POSITION)  
-DL: DOUBLE ENDED WITH FRICTION LOCK (SEE SHEET 2, FIG 4) (ONLY AVAILABLE ON \*5,\*7, 10 THRU 50 POSITION) (MUST CHOOSE FROM -NXX OPTIONS)  
-SR: SINGLE ENDED WITH RETENTION LATCH (SEE SHEET 3, FIG 5) (ONLY AVAILABLE ON -02 THRU -50 POS)  
-DR: DOUBLE ENDED WITH RETENTION LATCH (SEE SHEET 3, FIG 6) (ONLY AVAILABLE ON -02 THRU -50 POS) (MUST CHOOSE FROM -NXX OPTIONS)  
-SS: DUAL SCREW DOWN, SINGLE ENDED CABLE (SEE SHT 4, FIG 7) (SEE NOTE 15) (NOT AVAILABLE WITH OPTIONS SL, DL, SR & DR USES ISDF-XX-D-DS, CPS-RR-XX-XX-X & ACCRT-01)  
-DS: DUAL SCREW DOWN, DOUBLE ENDED CABLE (SEE SHT 4, FIG 8) (SEE NOTE 15) (NOT AVAILABLE WITH OPTIONS SL, DL, SR & DR USES ISDF-XX-D-DS, CPS-RR-XX-XX-X & ACCRT-01, MUST CHOOSE FROM NXXX OPTIONS)

**TABLE 3: PLATING**

PLATING	CONTACT
-H	C-203-2830-H or CC03X-2830-01-H
-GF	C-203-2830-GF or CC03X-2830-01-GF
-G	C-203-2830-G or CC03X-2830-01-G
-F	C-203-2830-GF or CC03X-2830-01-GF

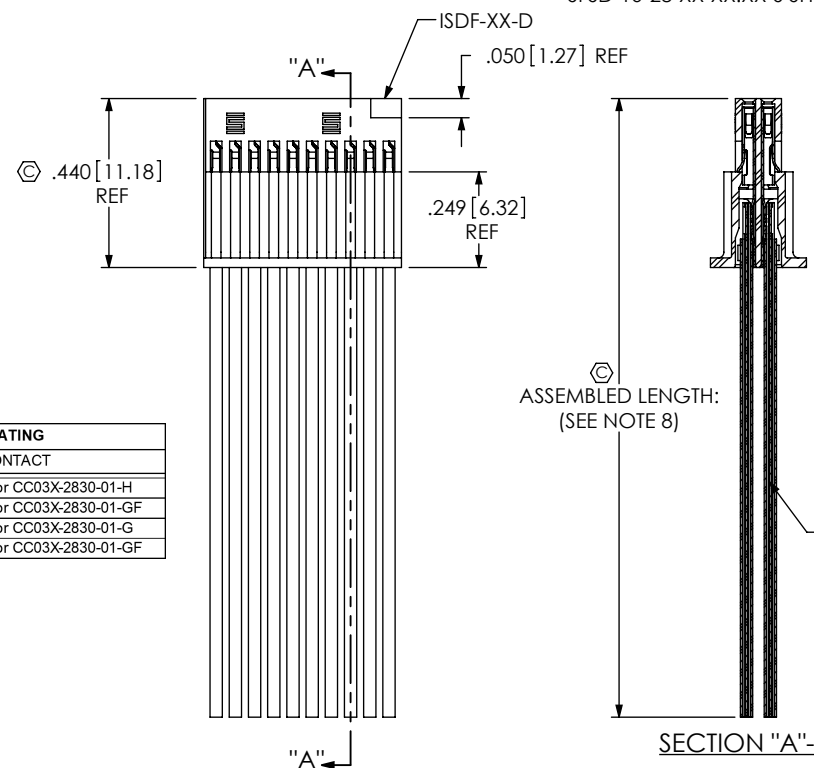

ASSEMBLED LENGTH: (SEE NOTE 8)

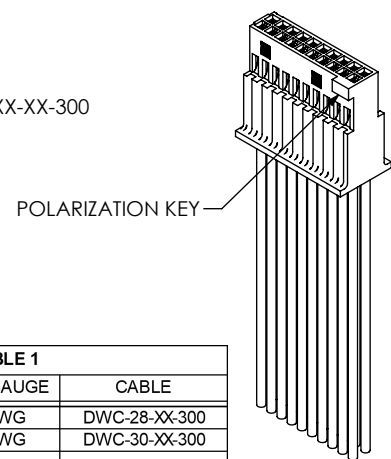

(\* = NOT AVAILABLE WITH POLARIZATION KEY)

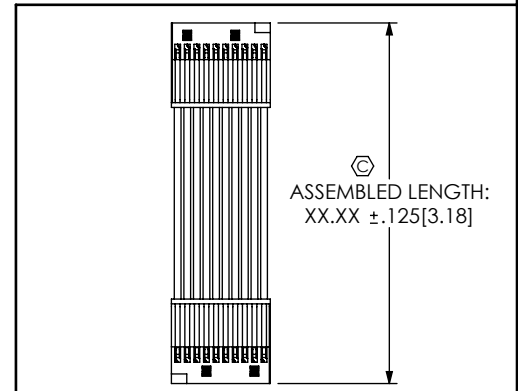

FIG 2  
-D: DOUBLE END  
SFSD-10-28-XX-XX-XX-D-NUS SHOWN (SAME AS FIG 1, UNLESS OTHERWISE STATED)

NOTES:

- REPRESENTS A CRITICAL DIMENSION.
- MINIMUM PULLOUT FORCE: 3.0 LBS [13.3 N].
- CONTACT MUST BE INSERTED UNTIL RETENTION FEATURE LOCKS INTO PLACE.
- ALL FINISHED GOODS ARE TO BE ELECTRICAL TESTED INCLUDING HI-POT TEST AT 1000 VOLTS DC. AFTER FINAL ELECTRICAL TEST, LABEL EACH ASSEMBLY WITH 1 LABEL-ET STAMP ON THE BODY.
- TINNED COPPER WIRE IS RoHS COMPLIANT.
- ALL CABLES TO BE LAYERED PACKAGED; ANY CABLE LONGER THAN 14" TO ALSO BE COILED AND CONTAINED USING TWIST TIE.
- NOTE DELETED.
- FOR LENGTHS LESS THAN 12 in. TOLERANCE SHALL BE +/- .125. FOR OTHER LENGTHS, TOLERANCE SHALL BE +/- 2%.
- NOTE DELETED.
- REFER TO CRIMP SPECIFICATIONS PRINT FOR CRIMP AND STRIP DIMENSIONS, TOLERANCES, TOOLING AND ITS REQUIREMENTS.
- 3LB MIN WIRE CRIMP STRENGTH FOR -30 AWG AND 4.5LB MIN WIRE CRIMP STRENGTH FOR -28 AWG.
- NOTE DELETED.
- TC TEFLON USE FOR DOUBLE ENDED ASSEMBLIES ONLY, ALL SINGLE ENDED ASSEMBLIES USE SILVER PLATED DWCT-XX-01.
- CUT LENGTH IS ASSEMBLY LENGTH MINUS OVERALL LENGTH SUBTRACTOR.
- THE PRODUCTS WITH OPTION -DS AND -SS SHOULD BE PACKAGED IN BUBBLE BAGS.

**TABLE 1**

SERIES	WIRE GAUGE	CABLE
SFSD	28 AWG	DWC-28-XX-300
SFSD	30 AWG	DWC-30-XX-300
SFSDT (SEE NOTE 13)	28 AWG	DWCT-28-XX-TC
SFSDT (SEE NOTE 13)	30 AWG	DWCT-30-XX-TC

UNLESS OTHERWISE SPECIFIED, DIMENSIONS ARE IN INCHES.  
TOLERANCES ARE:  
DECIMALS ANGLES  
.XX: ±.01 [.3] 2°  
.XXX: ±.005 [.13]  
.XXXX: ±.0020 [.051]

PROPRIETARY NOTE  
THIS DOCUMENT CONTAINS CONFIDENTIAL AND PROPRIETARY INFORMATION AND ALL DESIGN, MANUFACTURING, REPRODUCTION, USE, PATENT RIGHTS AND SALES RIGHTS ARE EXPRESSLY RESERVED BY SAMTEC, INC. THIS DOCUMENT SHALL NOT BE DISCLOSED, IN WHOLE OR PART, TO ANY UNAUTHORIZED PERSON OR ENTITY NOR REPRODUCED, TRANSFERRED OR INCORPORATED IN ANY OTHER PROJECT IN ANY MANNER WITHOUT THE EXPRESS WRITTEN CONSENT OF SAMTEC, INC.

MATERIAL: DO NOT SCALE DRAWING SHEET SCALE: 2:1  
INSULATOR: LCP UL 94V-0, COLOR: BLACK  
CONTACT: BeCu  
CABLE INSULATION: PVC OR FEP  
WIRE: DWC: TINNED COPPER.

**samtec**  
520 PARK EAST BLVD. NEW ALBANY, IN 47150  
PHONE: 812-944-6733 FAX: 812-948-5047  
e-Mail: info@SAMTEC.com code 55322

DESCRIPTION:  
.050[1.27] SOCKET DISCRETE CABLE ASSEMBLY  
DWG. NO.  
**SFSDX-XX-XXX-XX-XX.XX-XX-XXX**  
BY: BRATCHER 5/5/2005 SHEET 1 OF 5

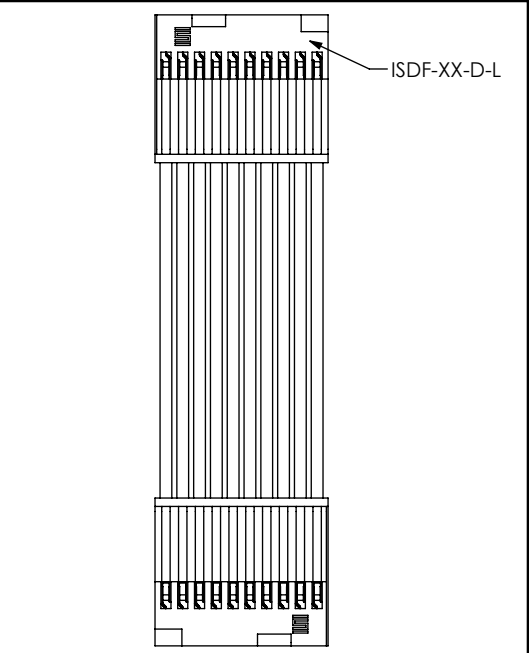
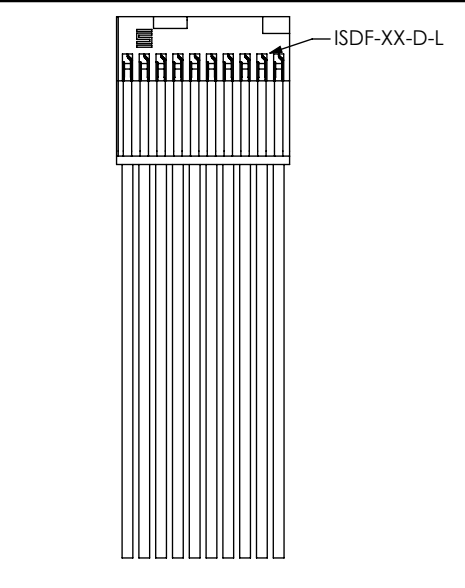
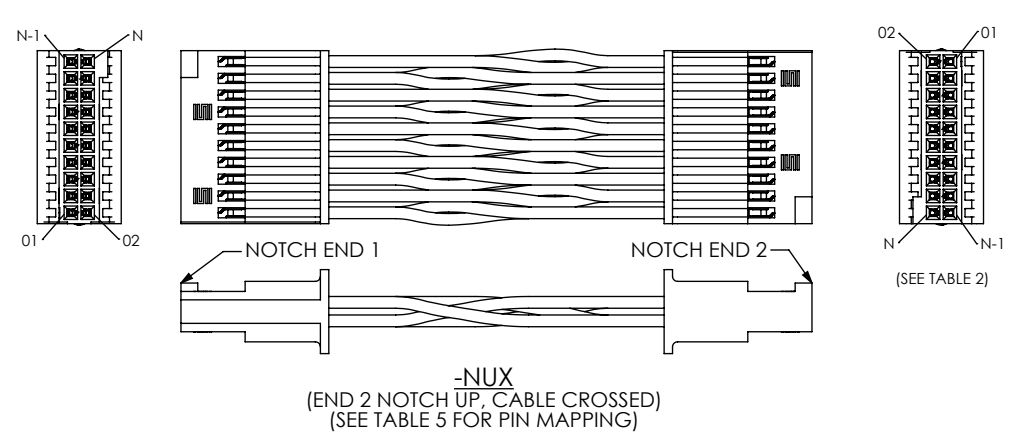
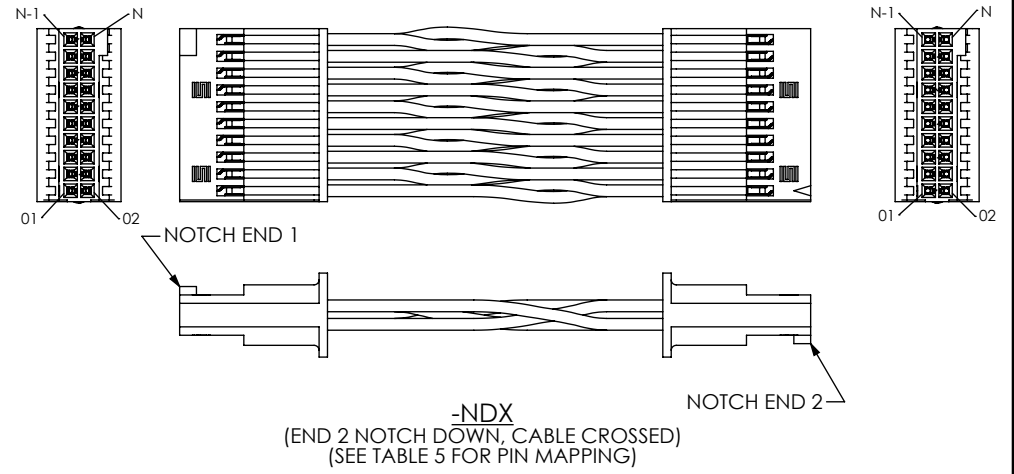
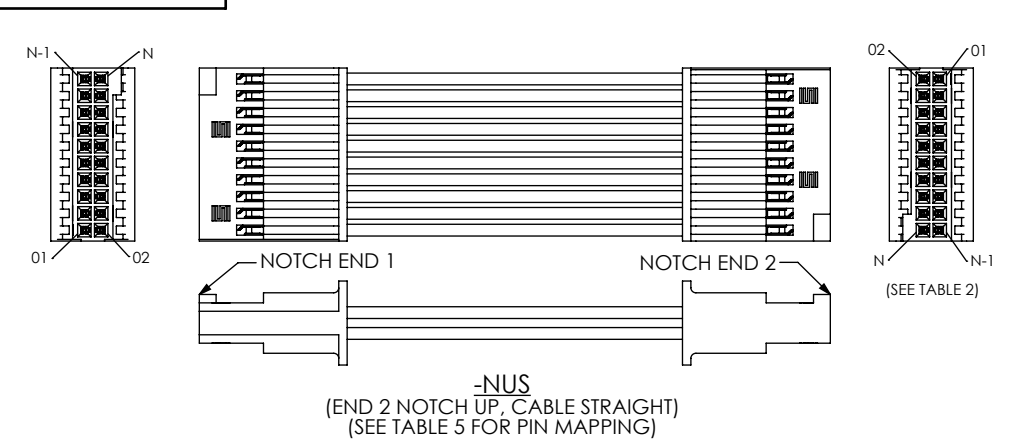

FIG 3  
-SL: SINGLE END FRICTION LOCK  
SFSDX-10-28-XX-XX.XX-SL SHOWN  
(SAME AS FIG 1, UNLESS OTHERWISE STATED)

FIG 4  
-DL: DOUBLE END FRICTION LOCK  
SFSDX-10-28-XX-XX.XX-DL-NUS SHOWN  
(SAME AS FIG 1, UNLESS OTHERWISE STATED)

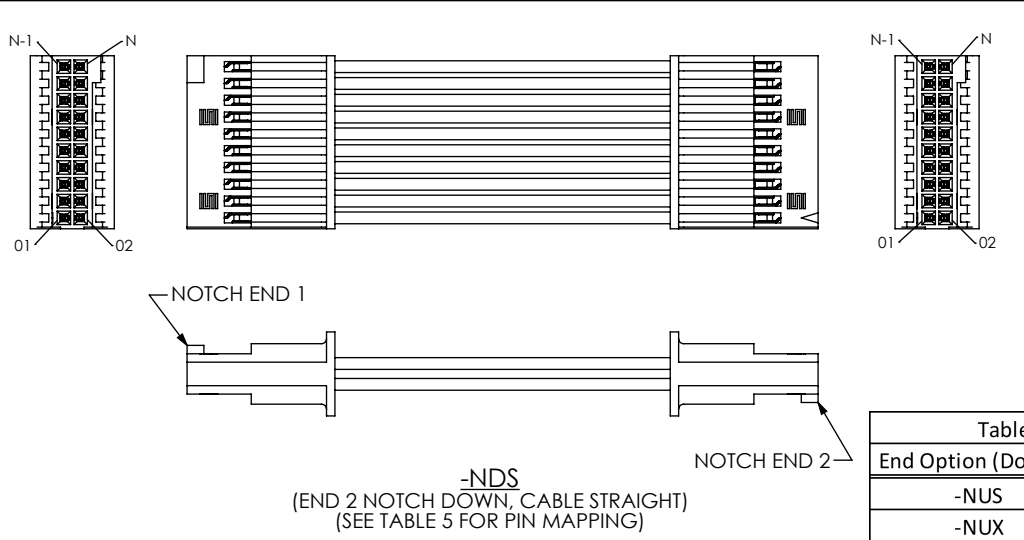

Table 5- Pin Mapping		
End Option (Double)	END 1	END 2
-NUS	01	N-1
-NUX	01	N
NDS	01	2
-NDX	01	1

**PROPRIETARY NOTE**  
THIS DOCUMENT CONTAINS CONFIDENTIAL AND PROPRIETARY INFORMATION AND ALL DESIGN, MANUFACTURING, REPRODUCTION, USE, PATENT RIGHTS AND SALES RIGHTS ARE EXPRESSLY RESERVED BY SAMTEC, INC. THIS DOCUMENT SHALL NOT BE DISCLOSED, IN WHOLE OR PART, TO ANY UNAUTHORIZED PERSON OR ENTITY NOR REPRODUCED, TRANSFERRED OR INCORPORATED IN ANY OTHER PROJECT IN ANY MANNER WITHOUT THE EXPRESS WRITTEN CONSENT OF SAMTEC, INC.

DO NOT SCALE DRAWING  
SHEET SCALE: 1:0.571429

**samtec**  
520 PARK EAST BLVD, NEW ALBANY, IN 47150  
PHONE: 812-944-6733 FAX: 812-948-5047  
e-Mail: info@SAMTEC.com code 55322

DESCRIPTION:  
.050[1.27] SOCKET DISCRETE CABLE ASSEMBLY

DWG. NO.  
SFSDX-XX-XXX-XX-XX.XX-XX-XXX

BY: BRATCHER 5/5/2005 SHEET 2 OF 5

REVISION AY

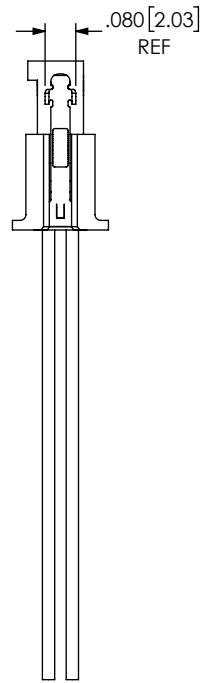
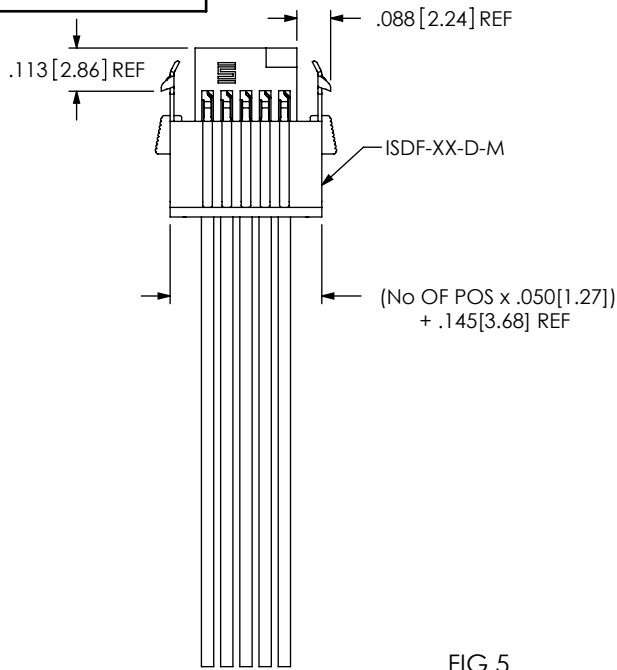

**FIG 5**  
 -SR: SINGLE END WITH RETENTION LATCH  
 SFSDX-05-28-XX-XX.XX-SR SHOWN  
 (ONLY AVAILABLE ON -02 THRU -50 POS)  
 (SAME AS FIG 1, UNLESS OTHERWISE STATED)

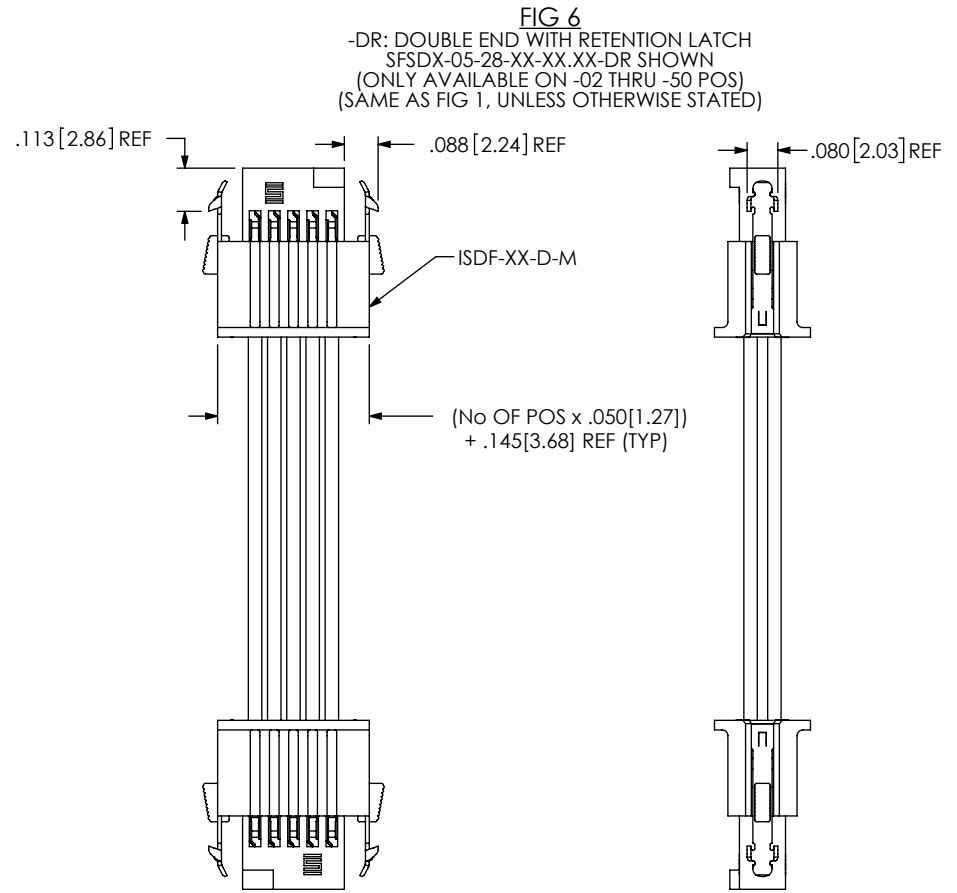

**FIG 6**  
 -DR: DOUBLE END WITH RETENTION LATCH  
 SFSDX-05-28-XX-XX.XX-DR SHOWN  
 (ONLY AVAILABLE ON -02 THRU -50 POS)  
 (SAME AS FIG 1, UNLESS OTHERWISE STATED)

**TABLE 4**

**SFSD color coded wire sequence**

	COLOR									
	brown	red	orange	yellow	green	violet	gray	white	black	blue
	DWC-XX-01-300	DWC-XX-02-300	DWC-XX-03-300	DWC-XX-04-300	DWC-XX-05-300	DWC-XX-07-300	DWC-XX-08-300	DWC-XX-09-300	DWC-XX-10-300	DWC-XX-13-300
pin #	1	2	3	4	5	6	7	8	9	10
	11	12	13	14	15	16	17	18	19	20
	21	22	23	24	25	26	27	28	29	30
	31	32	33	34	35	36	37	38	39	40
	41	42	43	44	45	46	47	48	49	50
	51	52	53	54	55	56	57	58	59	60
	61	62	63	64	65	66	67	68	69	70
	71	72	73	74	75	76	77	78	79	80
	81	82	83	84	85	86	87	88	89	90
	91	92	93	94	95	96	97	98	99	100

**PROPRIETARY NOTE**  
 THIS DOCUMENT CONTAINS CONFIDENTIAL AND PROPRIETARY INFORMATION AND ALL DESIGN, MANUFACTURING, REPRODUCTION, USE, PATENT RIGHTS AND SALES RIGHTS ARE EXPRESSLY RESERVED BY SAMTEC, INC. THIS DOCUMENT SHALL NOT BE DISCLOSED, IN WHOLE OR PART, TO ANY UNAUTHORIZED PERSON OR ENTITY NOR REPRODUCED, TRANSFERRED OR INCORPORATED IN ANY OTHER PROJECT IN ANY MANNER WITHOUT THE EXPRESS WRITTEN CONSENT OF SAMTEC, INC.

DO NOT SCALE DRAWING

SHEET SCALE: 4:1



520 PARK EAST BLVD, NEW ALBANY, IN 47150  
 PHONE: 812-944-6733 FAX: 812-948-5047  
 e-Mail info@SAMTEC.com code 55322

DESCRIPTION:  
 .050 [1.27] SOCKET DISCRETE CABLE ASSEMBLY

DWG. NO.  
**SFSDX-XX-XXX-XX-XX.XX-XX-XXX**

BY: BRATCHER 5/5/2005 SHEET 3 OF 5

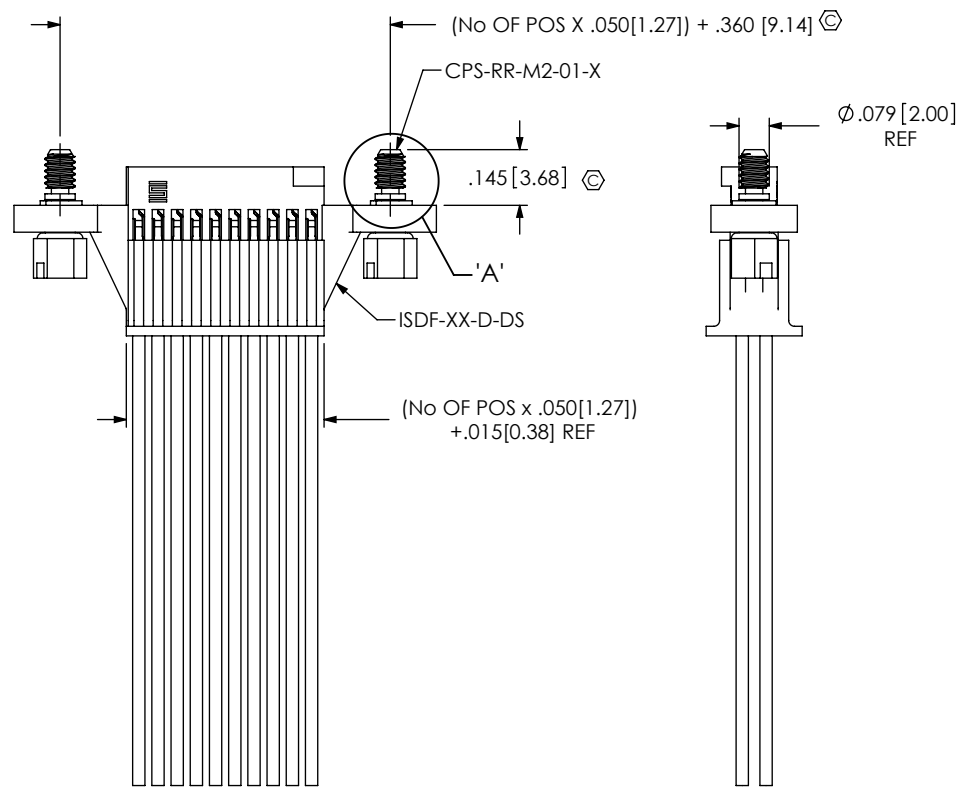

**FIG 7**  
 -SS: SINGLE END WITH SCREW DOWN  
 SFSDX-10-XXX-XX-XX.XX-SS SHOWN  
 (SAME AS FIG 1, UNLESS OTHERWISE STATED)

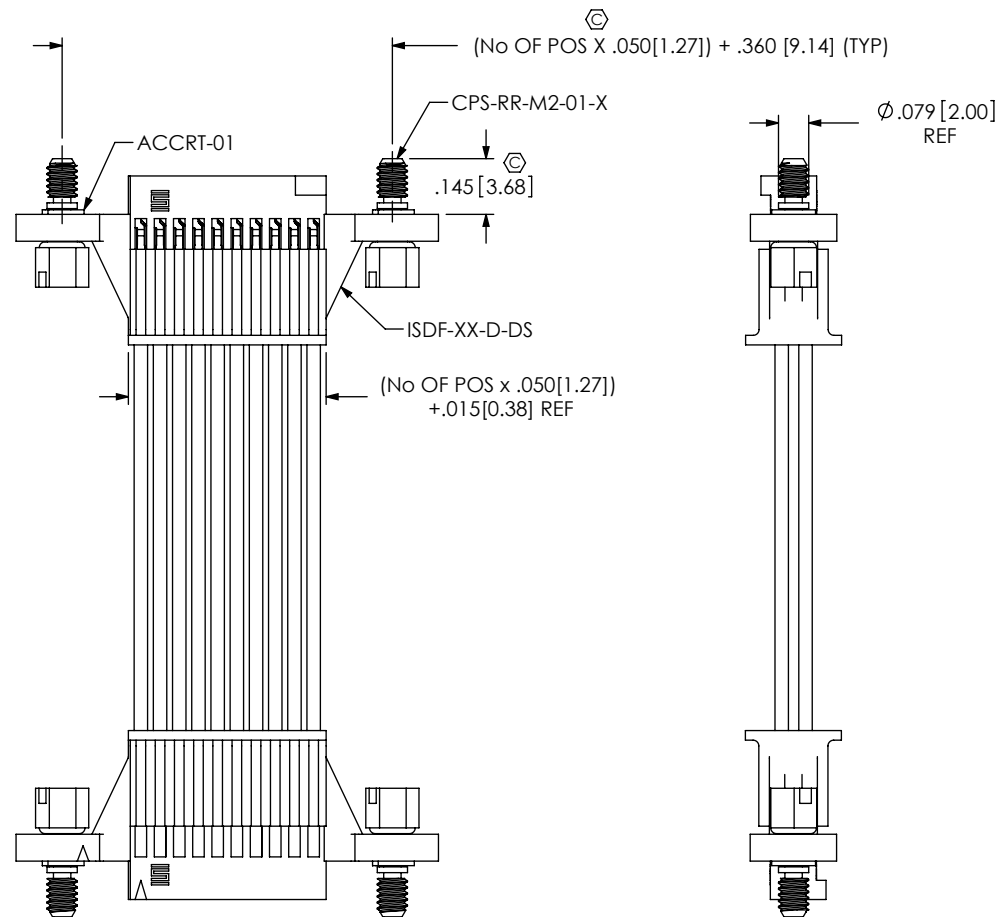
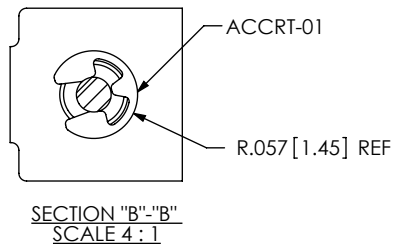
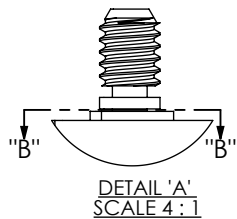

**FIG 8**  
 -DS: DOUBLE END WITH SCREW DOWN  
 SFSDX-10-XXX-XX-XX.XX-DS-NDS SHOWN  
 (MUST CHOOSE FROM -NXXX OPTIONS)  
 (SAME AS FIG 1, UNLESS OTHERWISE STATED)

**PROPRIETARY NOTE**  
 THIS DOCUMENT CONTAINS CONFIDENTIAL AND PROPRIETARY INFORMATION AND ALL DESIGN, MANUFACTURING, REPRODUCTION, USE, PATENT RIGHTS AND SALES RIGHTS ARE EXPRESSLY RESERVED BY SAMTEC, INC. THIS DOCUMENT SHALL NOT BE DISCLOSED, IN WHOLE OR PART, TO ANY UNAUTHORIZED PERSON OR ENTITY NOR REPRODUCED, TRANSFERRED OR INCORPORATED IN ANY OTHER PROJECT IN ANY MANNER WITHOUT THE EXPRESS WRITTEN CONSENT OF SAMTEC, INC.

DO NOT SCALE DRAWING  
 SHEET SCALE: 2:1



520 PARK EAST BLVD, NEW ALBANY, IN 47150  
 PHONE: 812-944-6733 FAX: 812-948-5047  
 e-Mail info@SAMTEC.com code 55322

DESCRIPTION: .050[1.27] SOCKET DISCRETE CABLE ASSEMBLY
DWG. NO. SFSDX-XX-XXX-XX-XX.XX-XX-XXX
BY: BRATCHER 5/5/2005
SHEET 4 OF 5

CABLE CUT IN-PROCESS

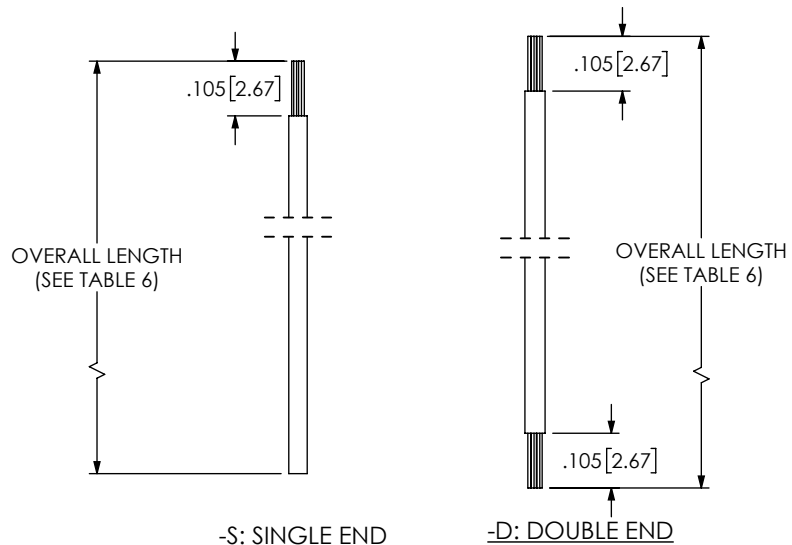

TABLE 6 ( OVERALL LENGTH SUBTRACTORS ) (SEE NOTE 14)	
	LENGTH
-S: SINGLE END	.249 [6.325]
-D: DOUBLE END	.498 [12.649]

**PROPRIETARY NOTE**  
 \* THIS DOCUMENT CONTAINS CONFIDENTIAL AND PROPRIETARY INFORMATION AND ALL DESIGN, MANUFACTURING, REPRODUCTION, USE, PATENT RIGHTS AND SALES RIGHTS ARE EXPRESSLY RESERVED BY SAMTEC, INC. THIS DOCUMENT SHALL NOT BE DISCLOSED, IN WHOLE OR PART, TO ANY UNAUTHORIZED PERSON OR ENTITY NOR REPRODUCED, TRANSFERRED OR INCORPORATED IN ANY OTHER PROJECT IN ANY MANNER WITHOUT THE EXPRESS WRITTEN CONSENT OF SAMTEC, INC. \*



520 PARK EAST BLVD, NEW ALBANY, IN 47150  
 PHONE: 812-944-6733 FAX: 812-948-5047  
 e-Mail info@SAMTEC.com code 55322

SHEET SCALE: 2:1

DESCRIPTION:  
 .050[1.27] SOCKET DISCRETE CABLE ASSEMBLY

DWG. NO.  
 SFSDX-XX-XXX-XX-XX.XX-XX-XXX

BY:BRATCHER 5/5/2005 SHEET 5 OF 5