

SPECIFICATION

- Part No. : **WM.90.A.305111**
- Product Name : Wall Mount Flexible Whip Monopole
High Gain 2G/3G/4G Wide-band Cellular Antenna
- Feature : 698-960MHz/1710-2690MHz
Unique - High peak gain on all bands
Wide-band High efficiency
Flexible Inner Steel Core Whip
Completely IP67, Robust Structure, Aesthetic
3M CFD-200 SMA(M)ST
Cable is hidden internally
RoHS compliant



1. Introduction

The WM.90 wall mount flexible whip monopole has high performance on all common 2G/3G/4G bands used worldwide. Taoglas specifications are compiled completely from real-life testing in state of the art CTIA approved 3D anechoic chambers. Peak gain, average gain/efficiency are both optimized to provide extended coverage area in the azimuth (horizontal direction), while also maintaining an Omni-directional pattern for close in reception/transmission. Testing of the whip antenna on the bracket, in free-space, and on a reference ground-plane has been done to show the benefit of the L-bracket.

This antenna delivers wider coverage areas and more reliable connections for professional customers in the automotive, industrial industries. The whip is made up of a flexible inner steel core covered by TPU so extremely resistant to collisions and maintaining its original shape and RF performance. The whip and the connection internally to the bracket is completely IP67 waterproof.

The bracket allows complete concealment of the cable for a more secure integration and cleaner installation. The cable can also be routed out of the back wall of the bracket into the interior of the mounting wall for added security against vandalism. The standard version comes with 3 metres extremely low loss CFD200 (0.3dB against 0.7dB for RG58) to allow for flexibility of placement. The cable and connector can be completely customized, the whip itself can also be changed for different frequency bands or gain requirements.

2. Specification

CELLULAR							
Frequency (MHz)	698 ~ 798	824 ~ 896	880 ~ 960	1710 ~ 1880	1850 ~ 1990	1710 ~ 2170	2570 ~ 2690
Peak Gain (dBi)							
Free Space	-2.11	-1.30	-0.27	2.45	3.35	2.83	3.45
On 30cm*30cm GND	-2.75	-0.84	2.02	4.65	5.09	4.55	4.65
L - Bracket	-1.11	2.53	1.80	1.81	2.23	2.22	1.80
Average Gain (dBi)							
Free Space	-6.30	-5.33	-4.59	-1.85	-1.51	-1.73	-2.13
On 30cm*30cm GND	-5.76	-4.62	-3.03	-1.73	-1.44	-1.69	-1.84
L - Bracket	-5.58	-2.33	-2.44	-2.71	-3.03	-2.75	-2.88
Efficiency (%)							
Free Space	23.49	29.32	35.08	65.41	70.84	67.30	61.58
On 30cm*30cm GND	26.60	34.93	50.32	67.30	71.81	67.94	65.54
L - Bracket	27.92	58.66	57.15	53.86	49.86	53.24	51.59
Return Loss (dB)	<-3	<-6	<-4	<-5	<-5	<-6	<-6
Impedance	50Ω						
Polarization	Linear						
Radiation Pattern	Omni						
Input Power	2 W						
MECHANICAL							
Dimensions	Height 248 ± 5 mm						
Base Diameter	17.08 ± 0.2 mm						
Whip Diameter	4 ± 0.2 mm						
Casing	ABS						
Connector	SMA Male						
Weight	420g						
ENVIRONMENTAL							
Temperature Range	-40°C to 85°C						
Humidity	Non-condensing 65°C 95% RH						
Tested with 3M CFD-200 SMA(M)ST							

3. Antenna Characteristics

3.1 Return loss

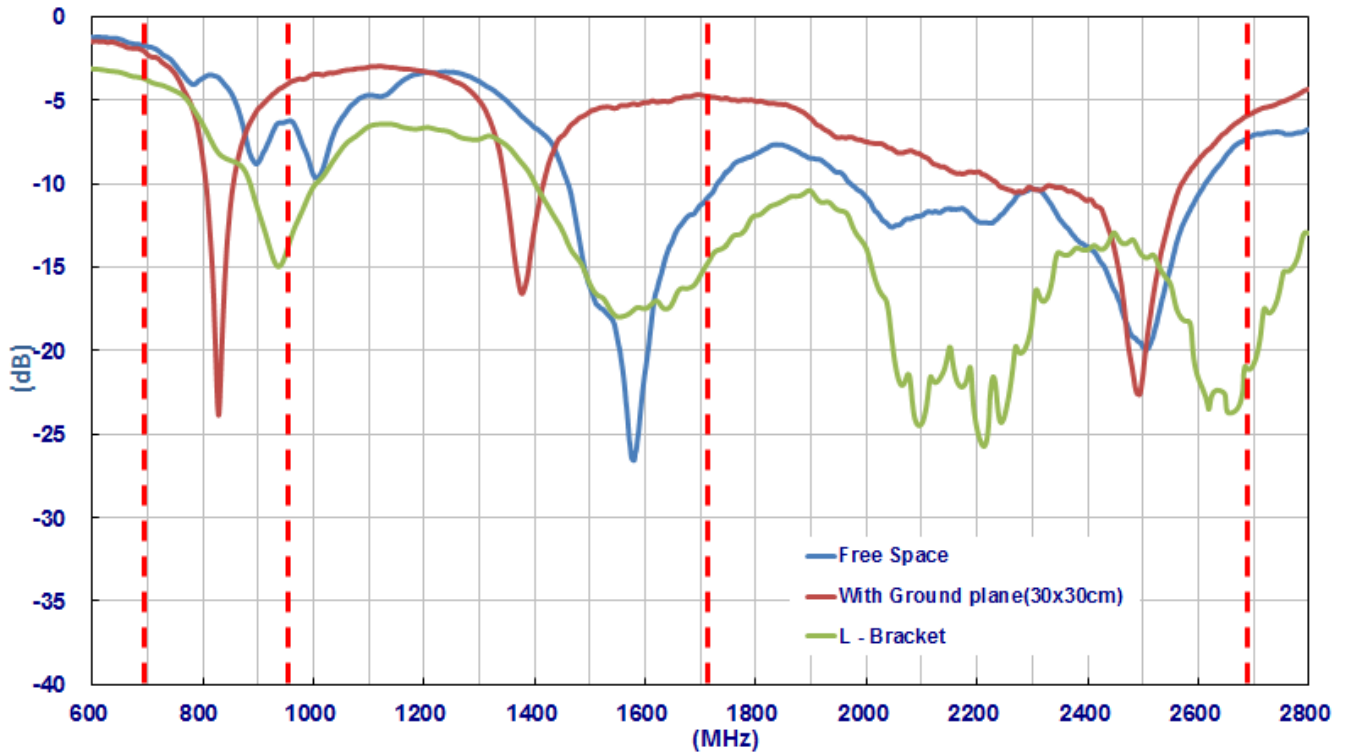

3.2 Antenna Efficiency

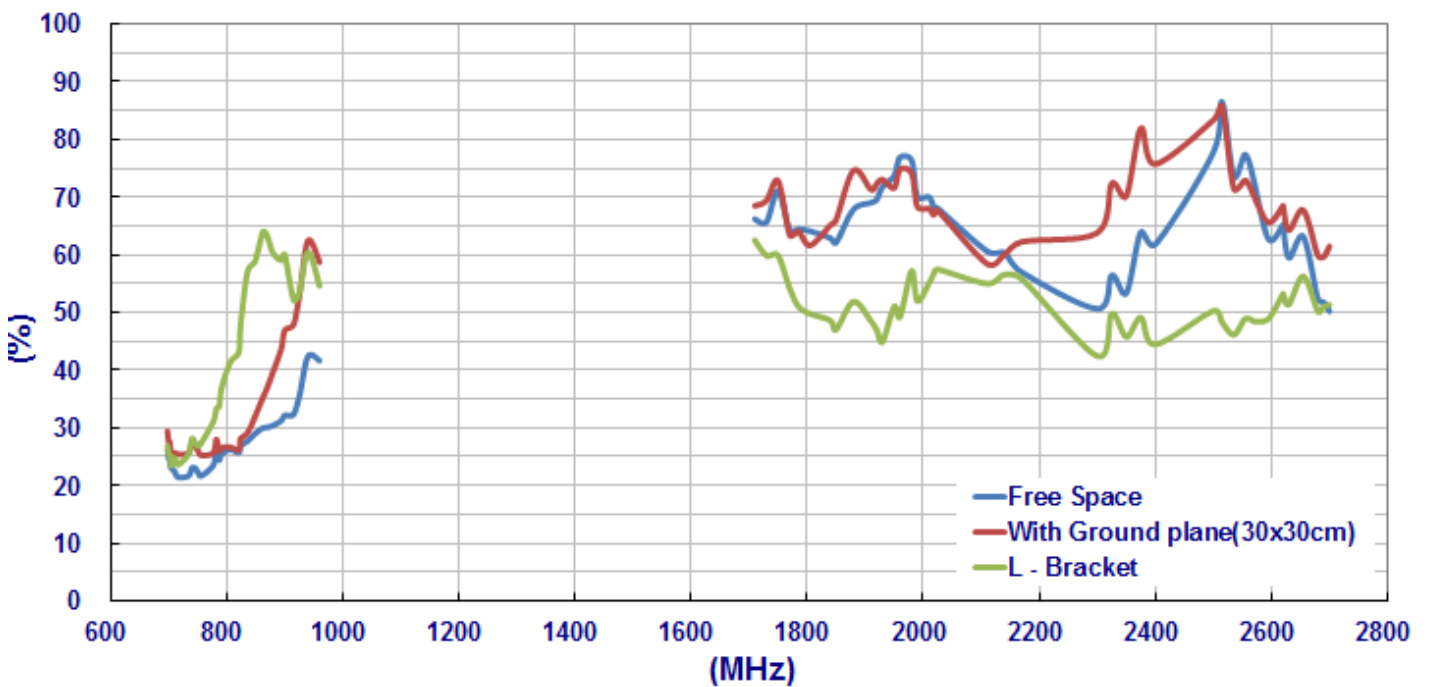

3.3 Peak Gain

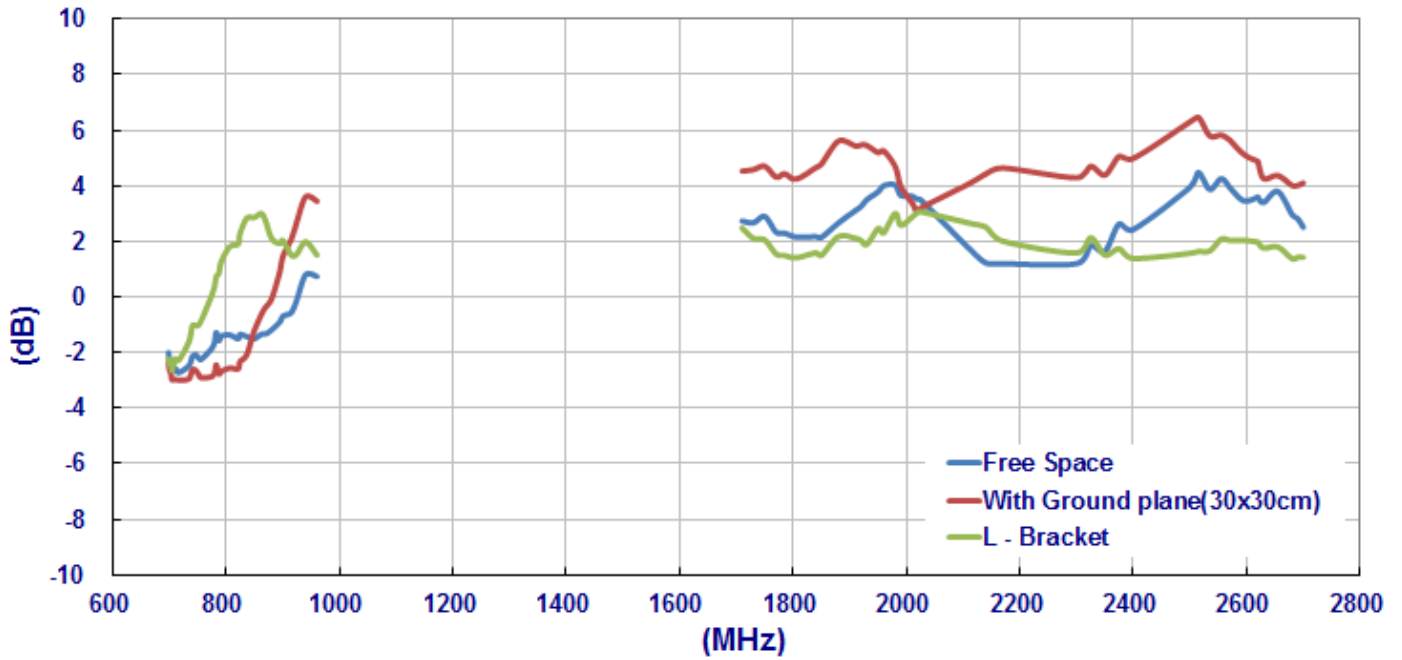

4. Antenna Radiation Pattern

4.1 Antenna Stand Alone

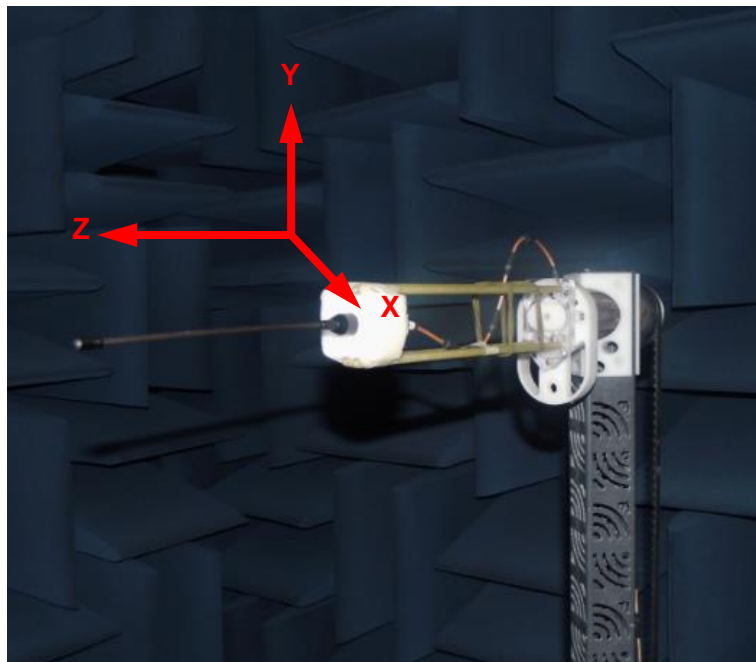

XY-plane

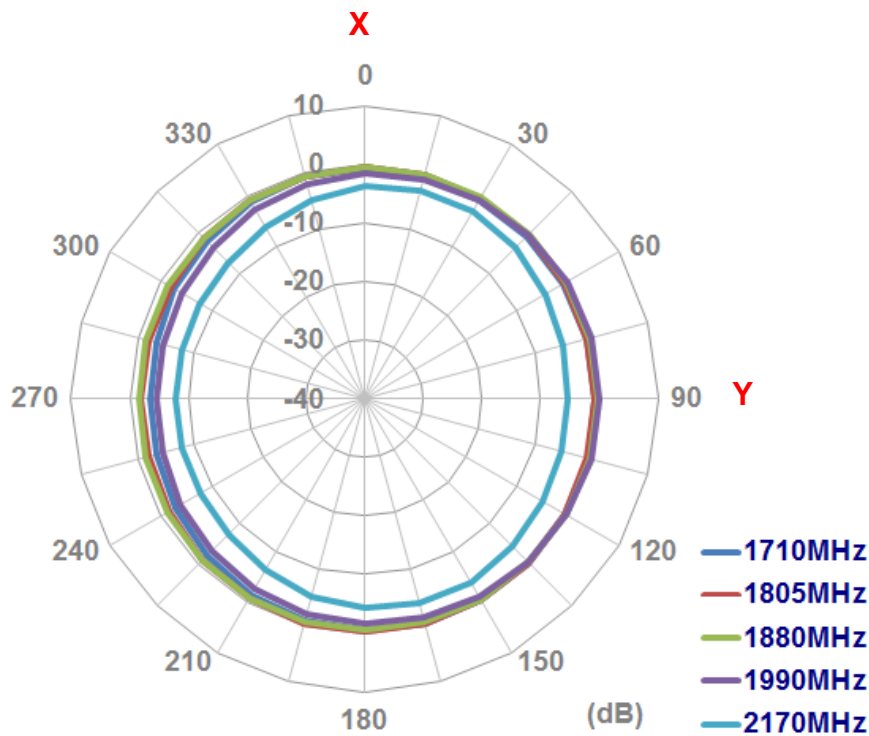
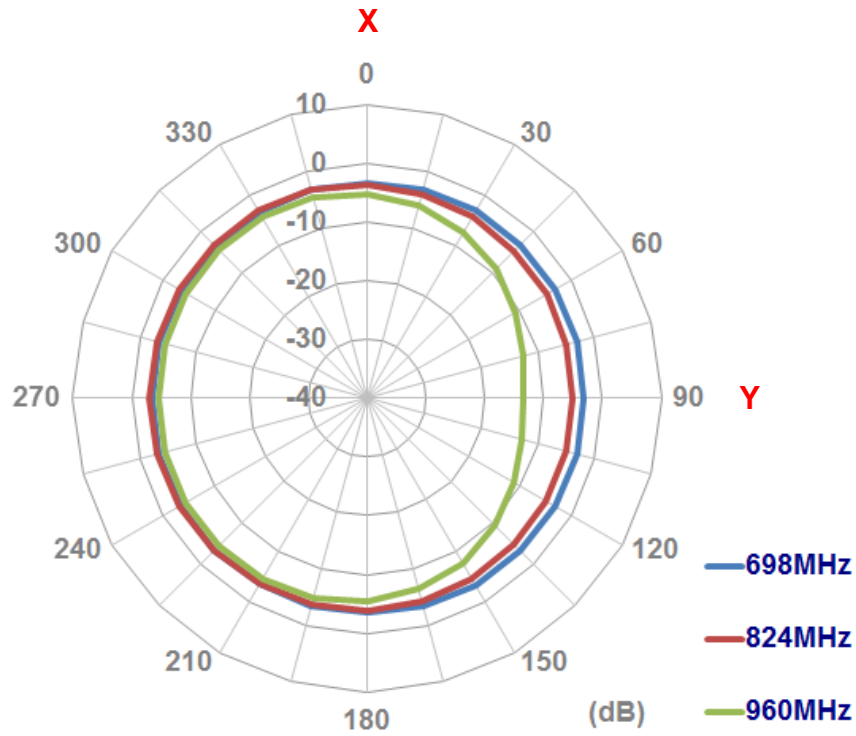

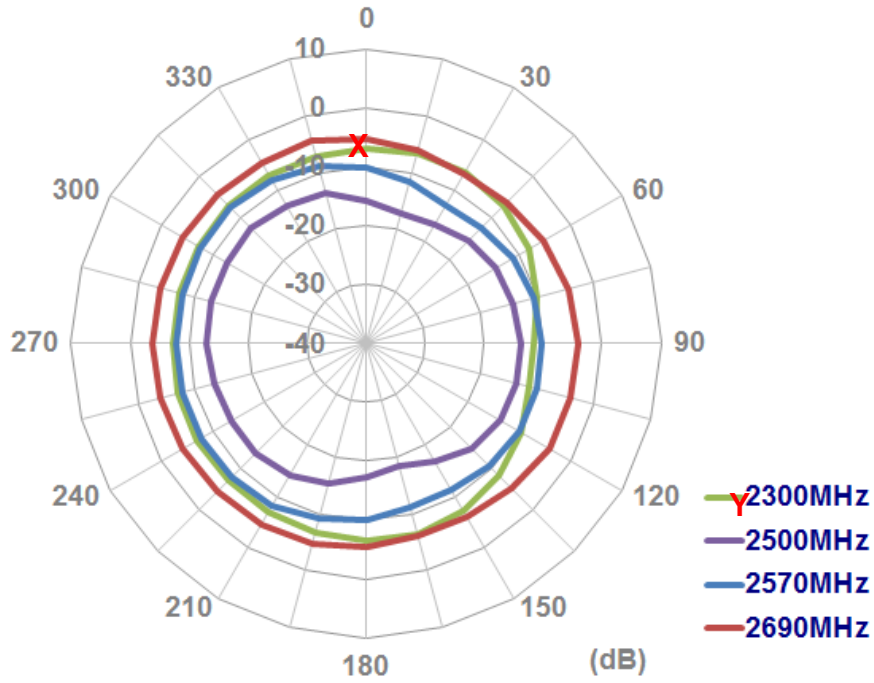

XZ-plane

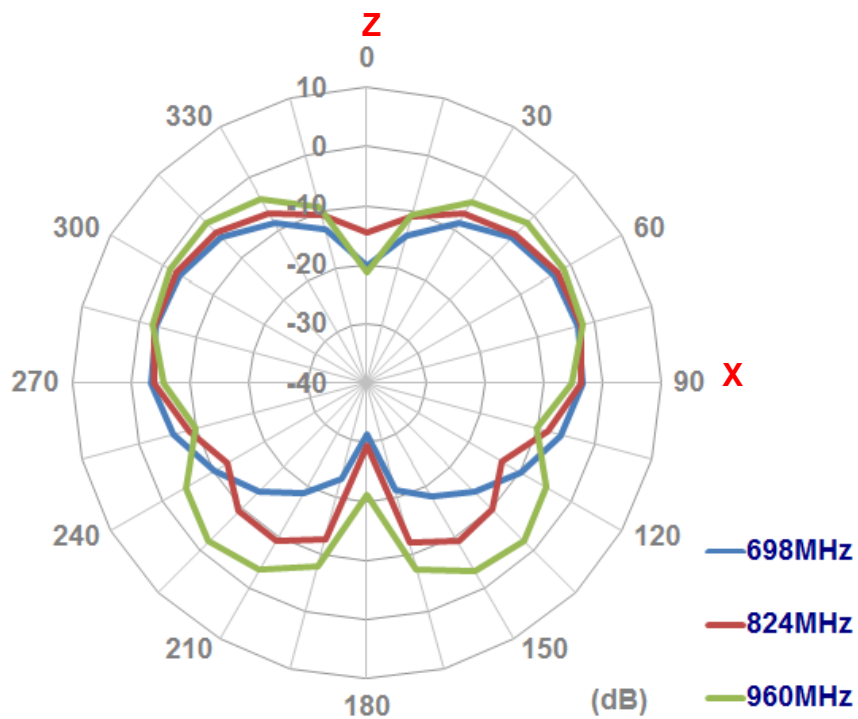

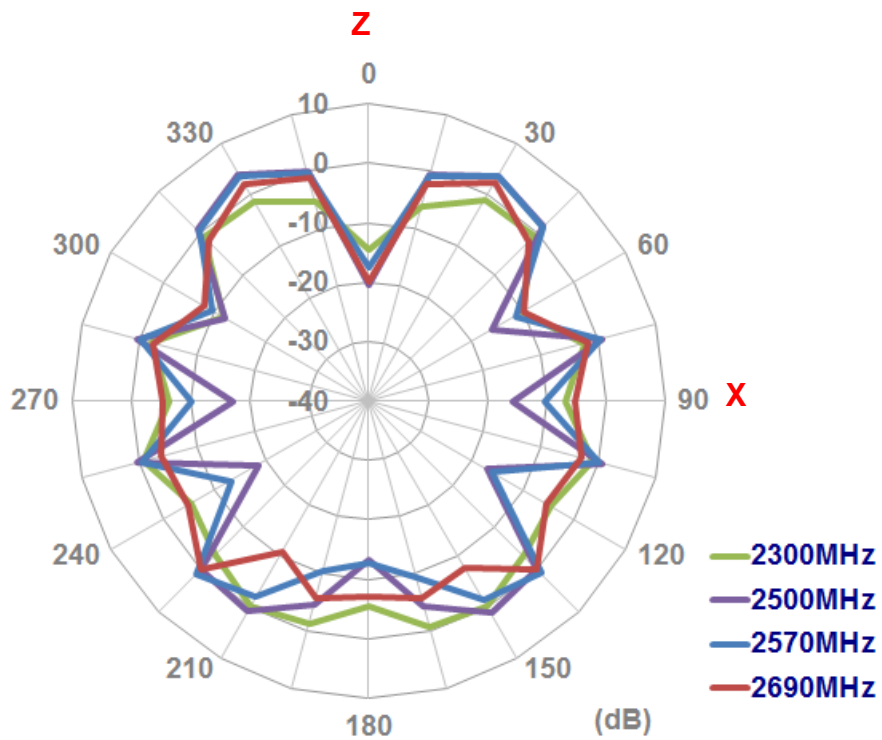
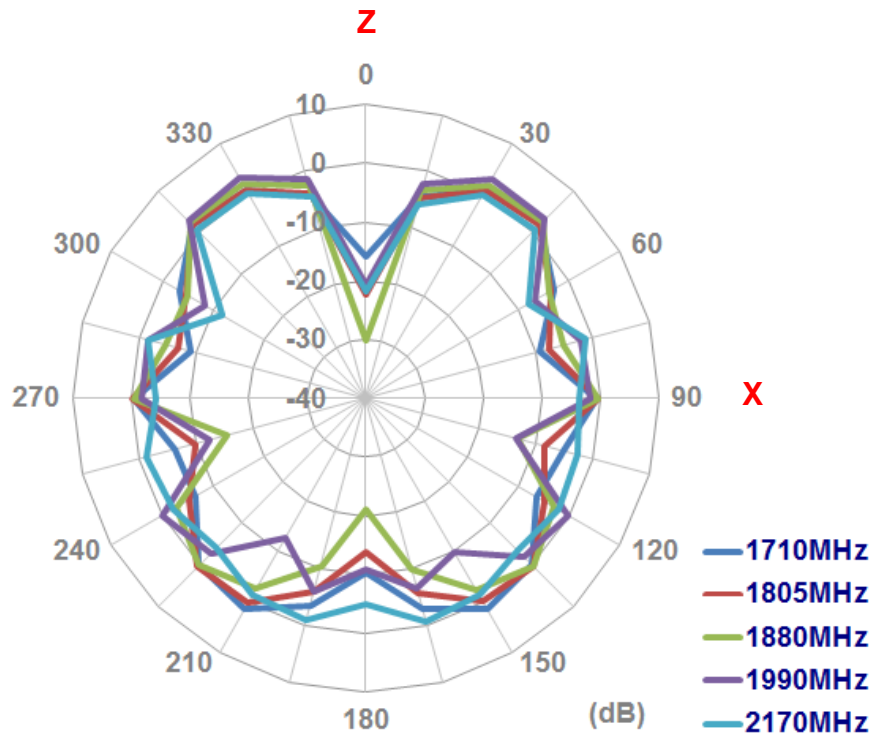

4.2 Antenna with Ground plane (30X30cm)

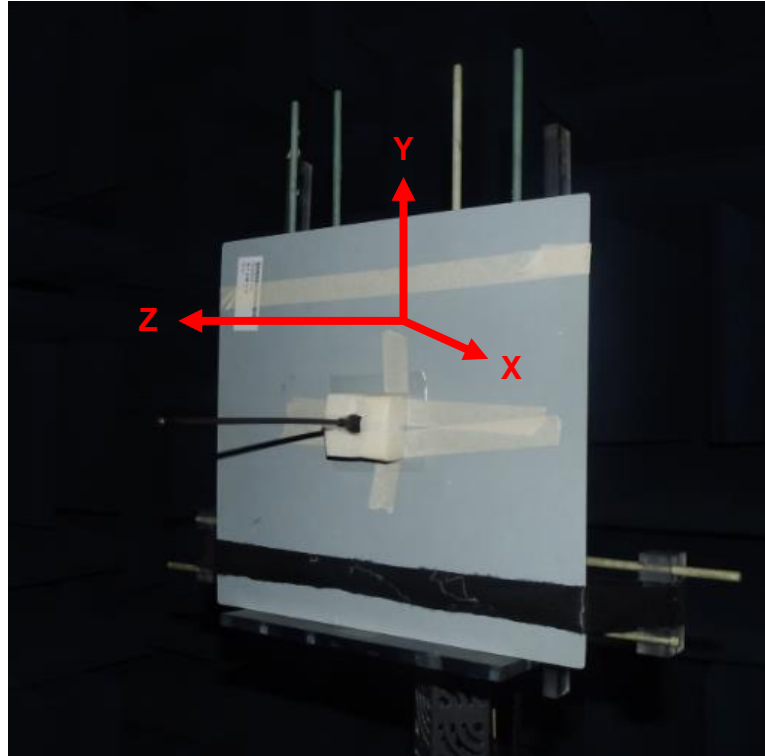

XY-plane

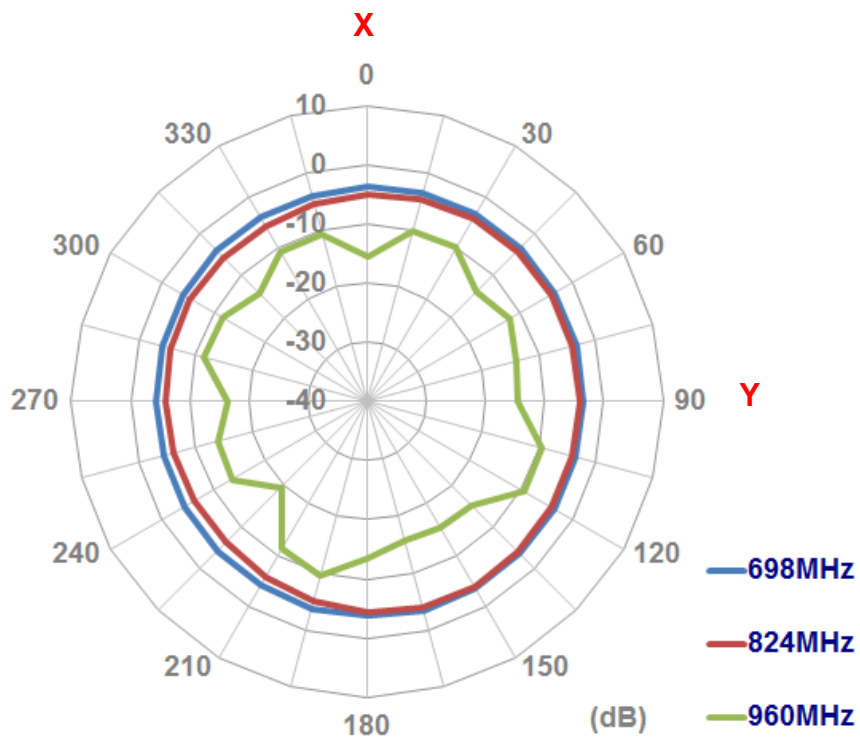

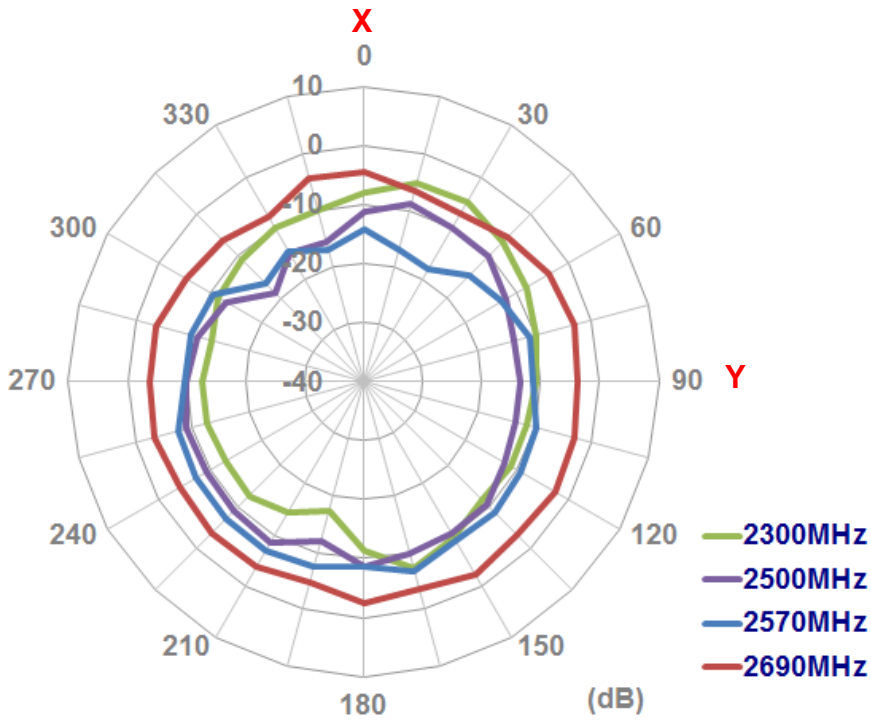
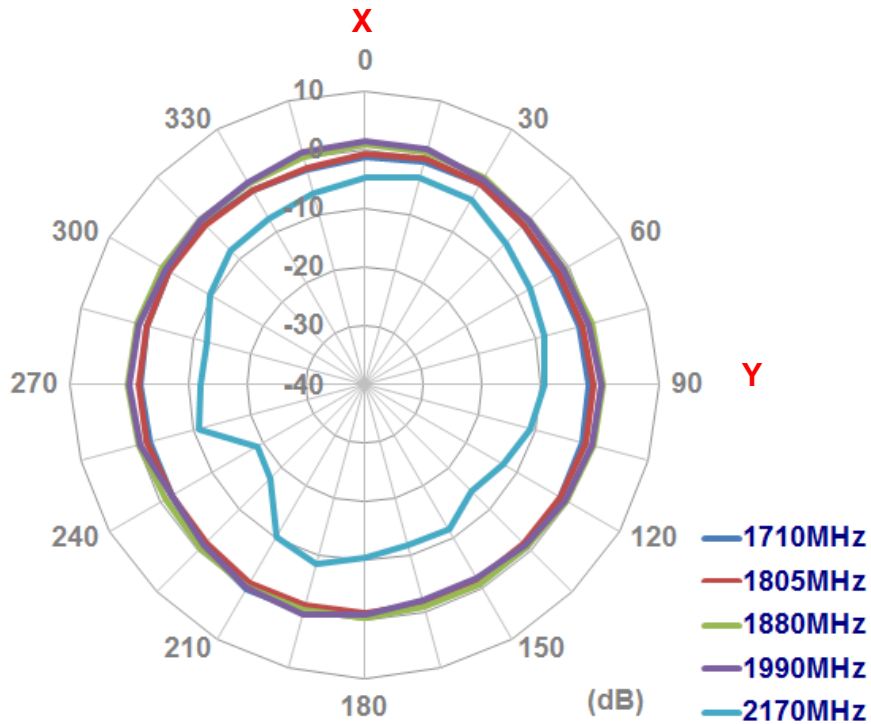

XZ-plane

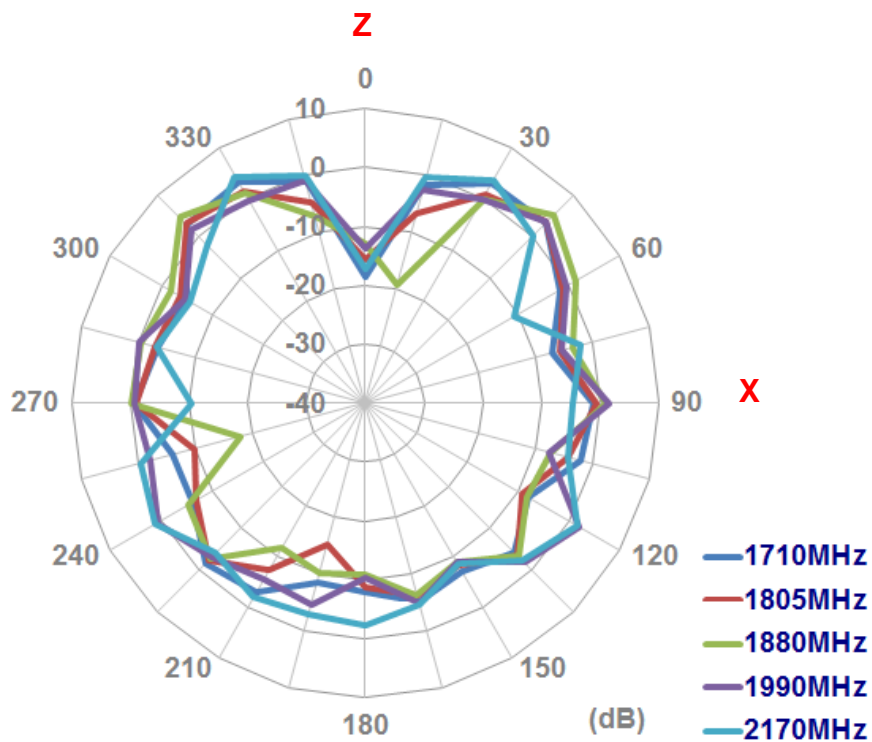
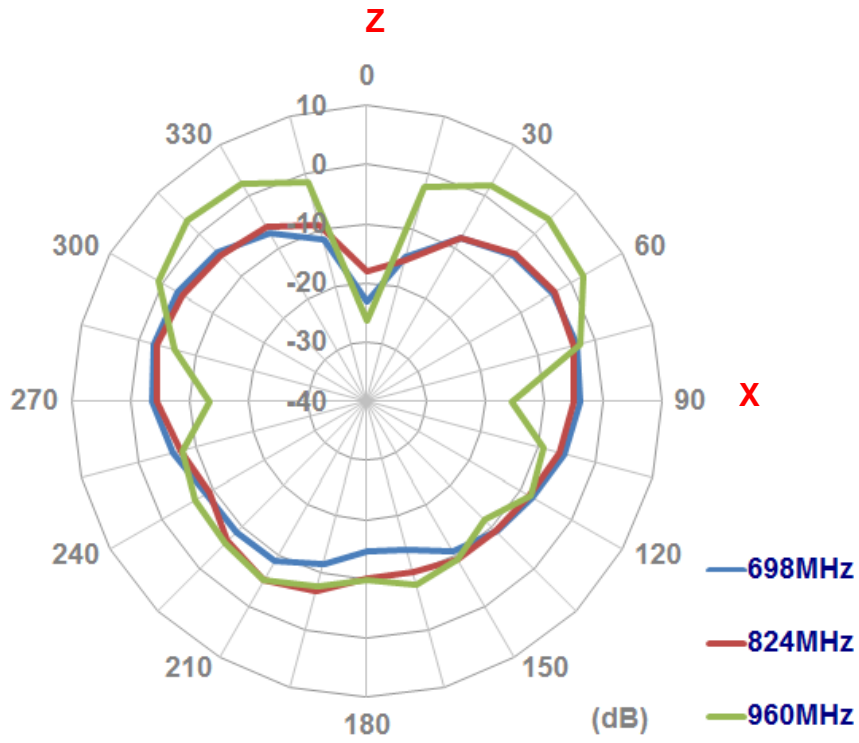

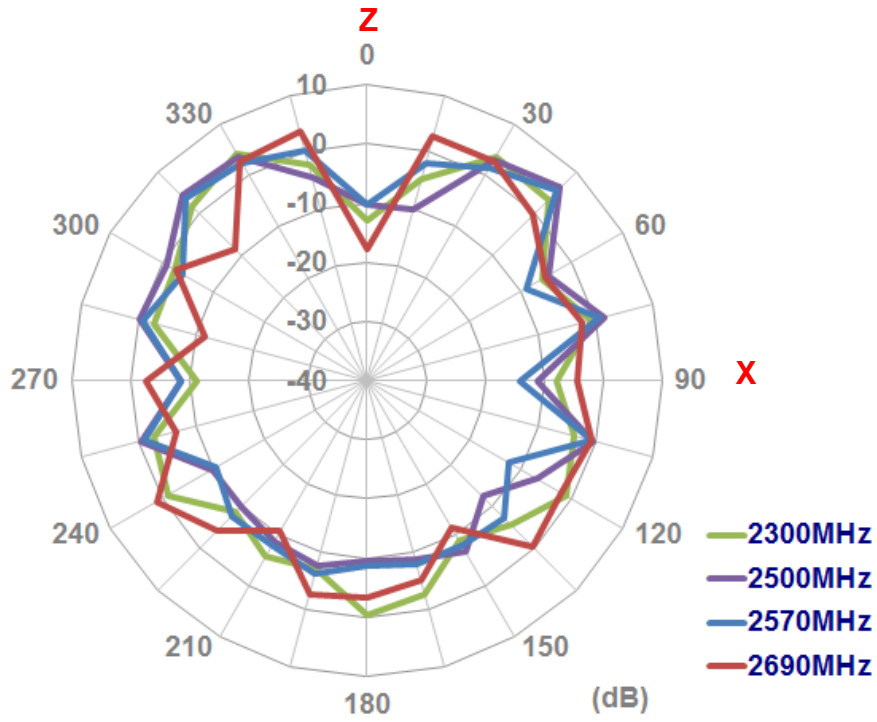

4.3 Antenna with L-Bracket

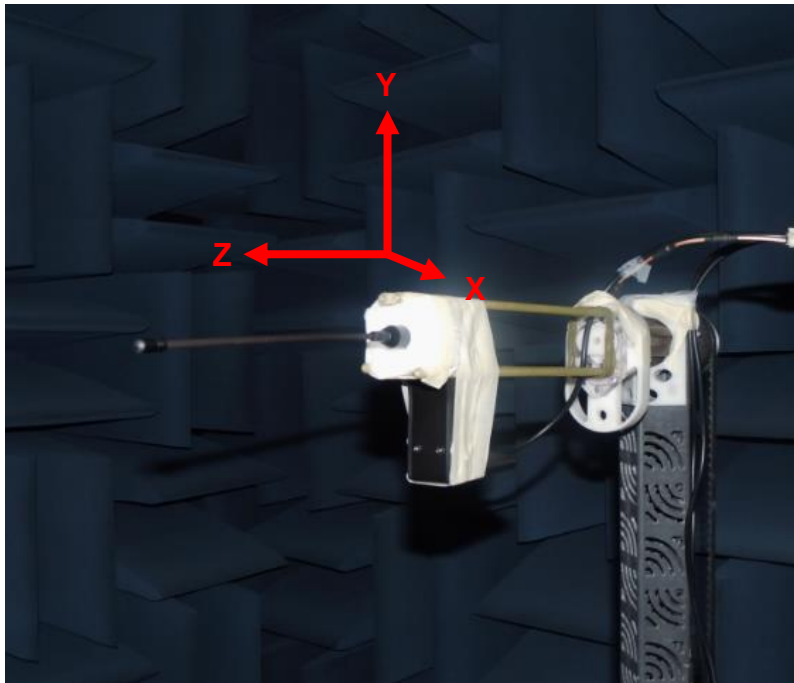

XY-plane

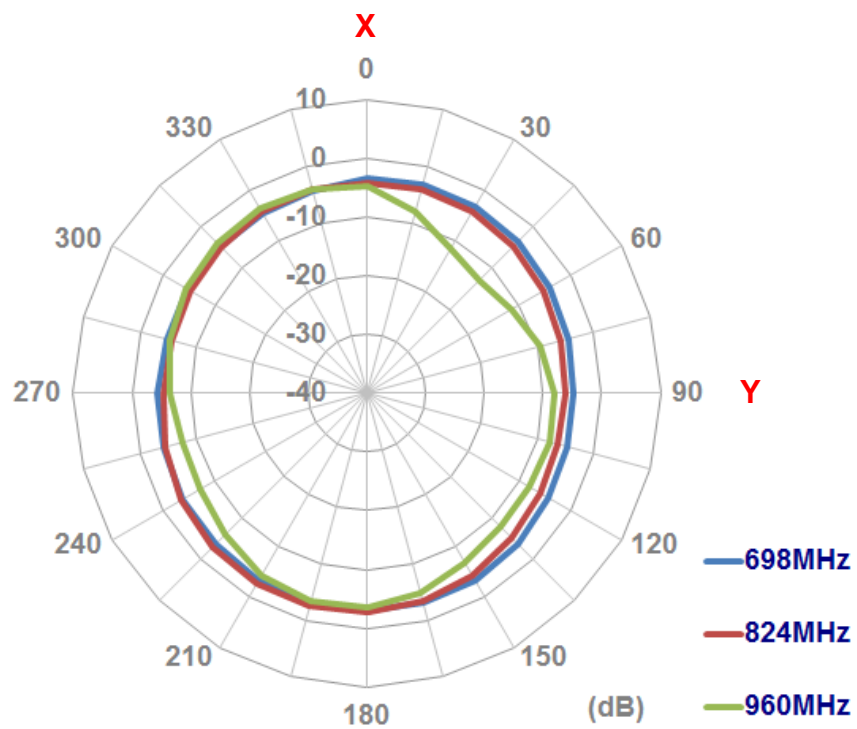

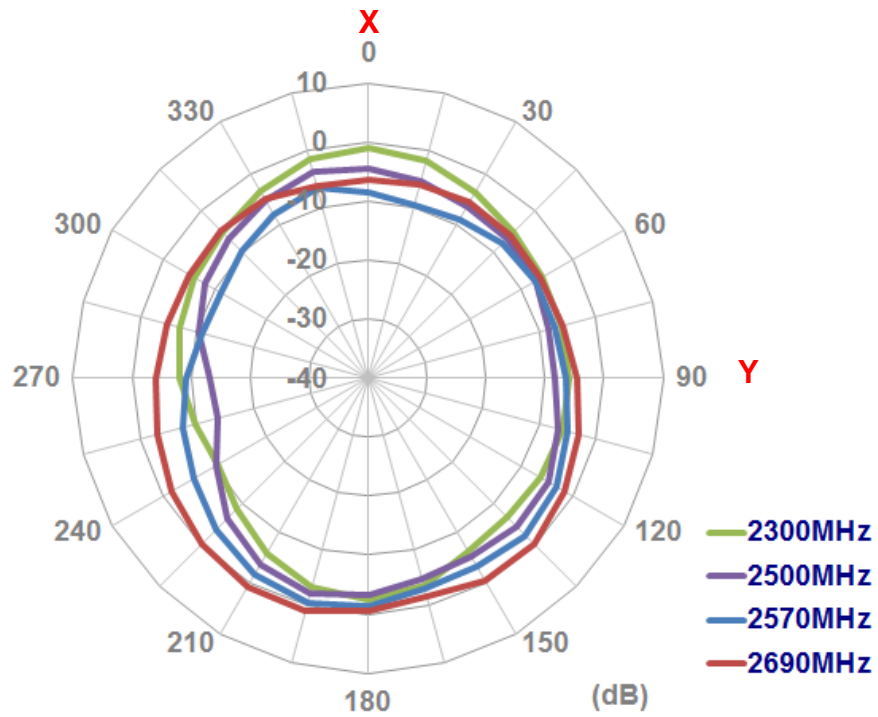
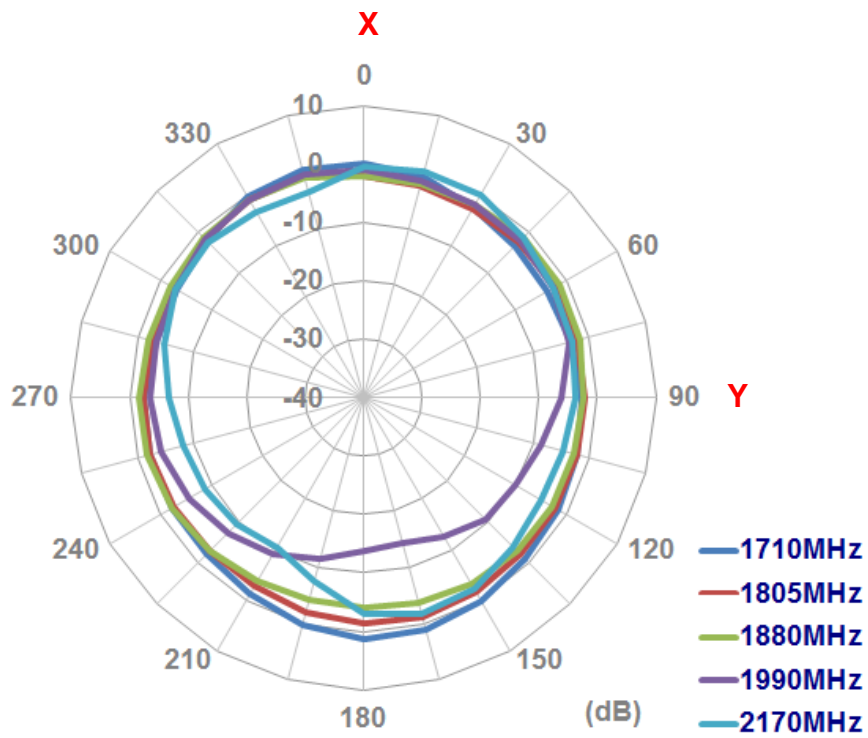

XZ-plane

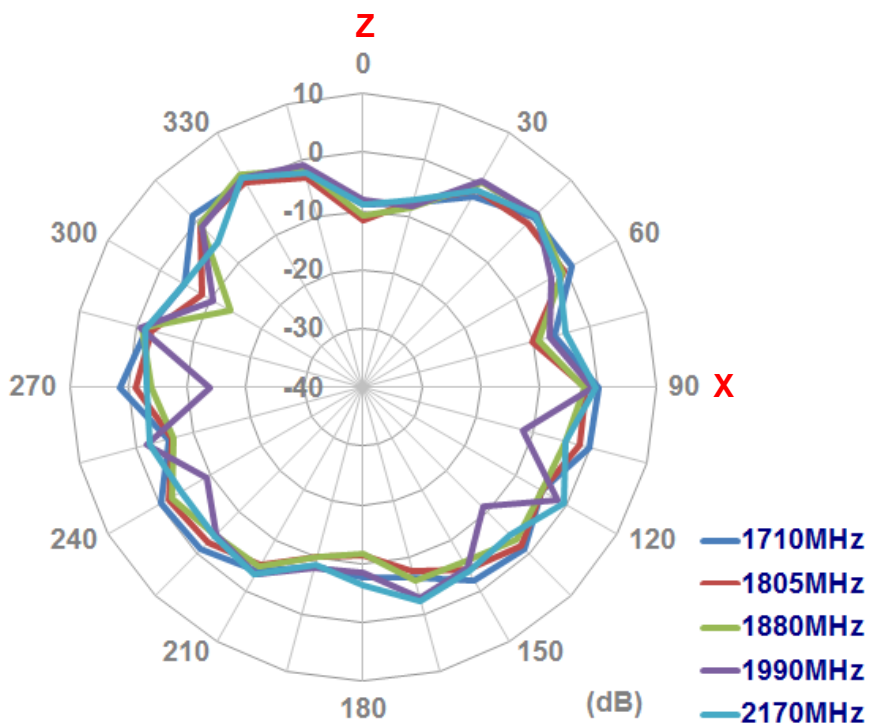
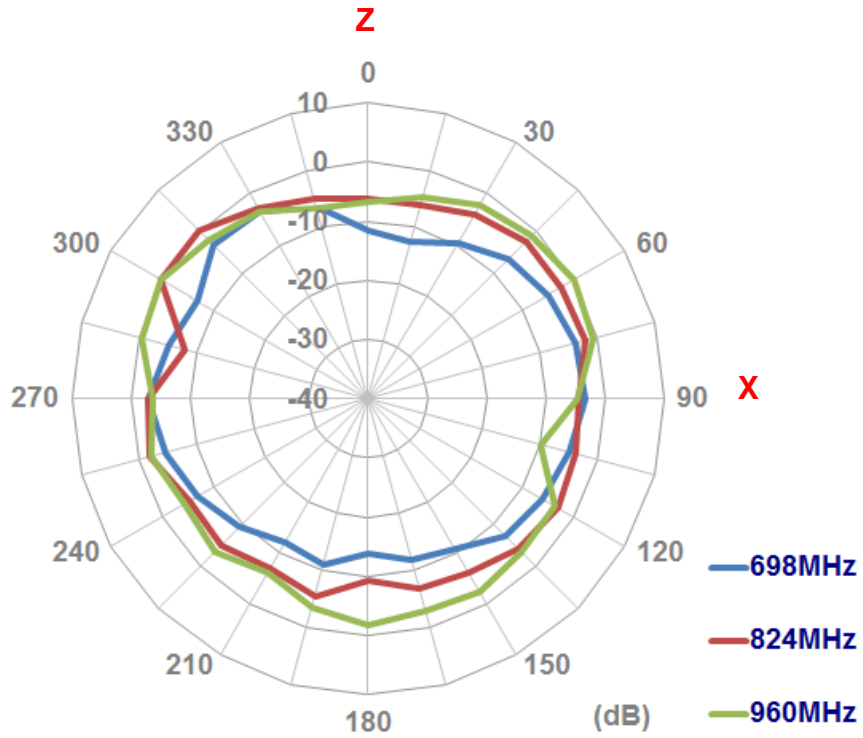

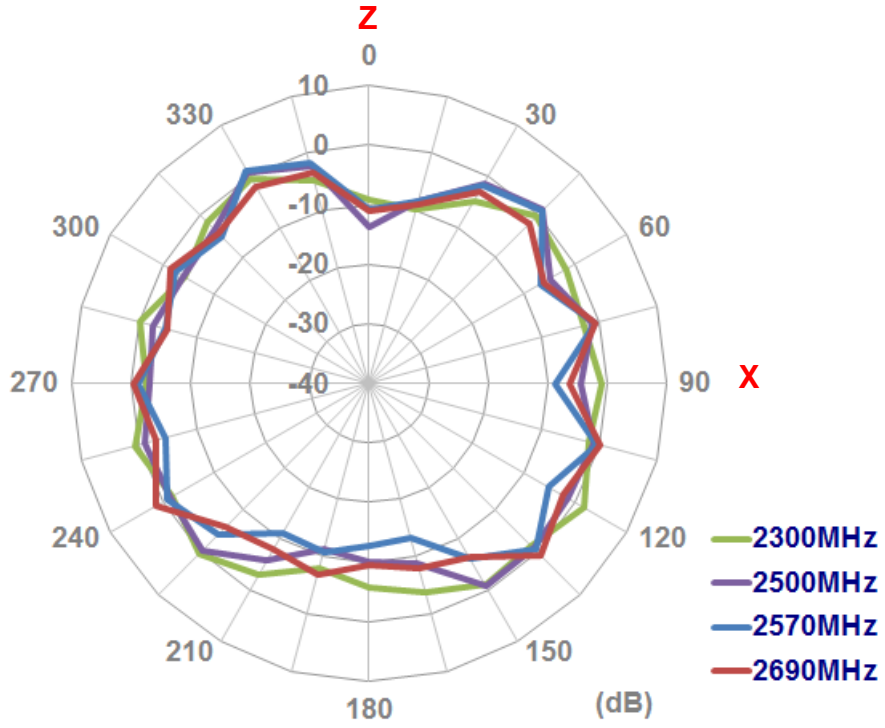

5. Antenna Drawing

	Name	Material	Finish	QTY
①	Main Bracket	PC	Black	1
②	Back Bracket	SPOC	Black	1
③	3"8L Screw	Steel	Black	6
④	Cap	ABS	Black	1
⑤	4"25L Screw	Stainless Steel	Clear	2
⑥	6"24L Wall Mount Stud	Nylon	White	2
⑦	CFD 200 Cable	PVC Jacket	Black	1
⑧	SMA(M) ST	Brass	Gold	1
⑨	Heat Shrink Tube	PE	Black	1
⑩	Housing	ABS	Black	1
⑪	Flexible Whip	Steel+PE Jacket	Black	1

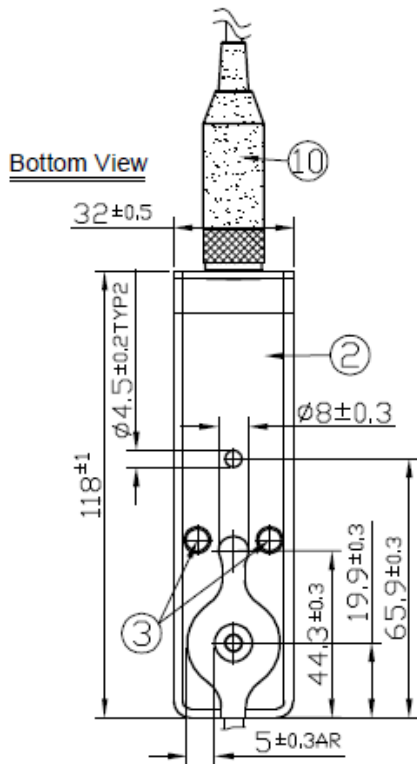

Side View

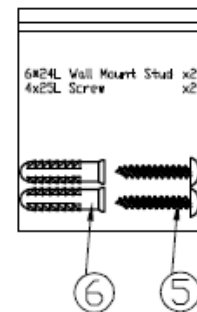
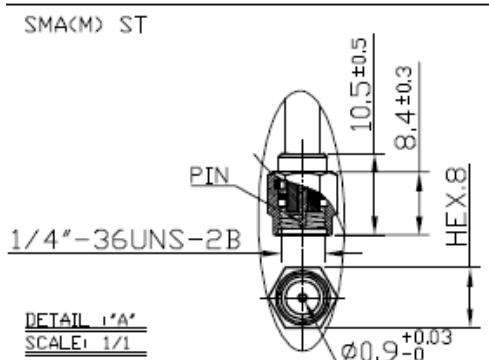
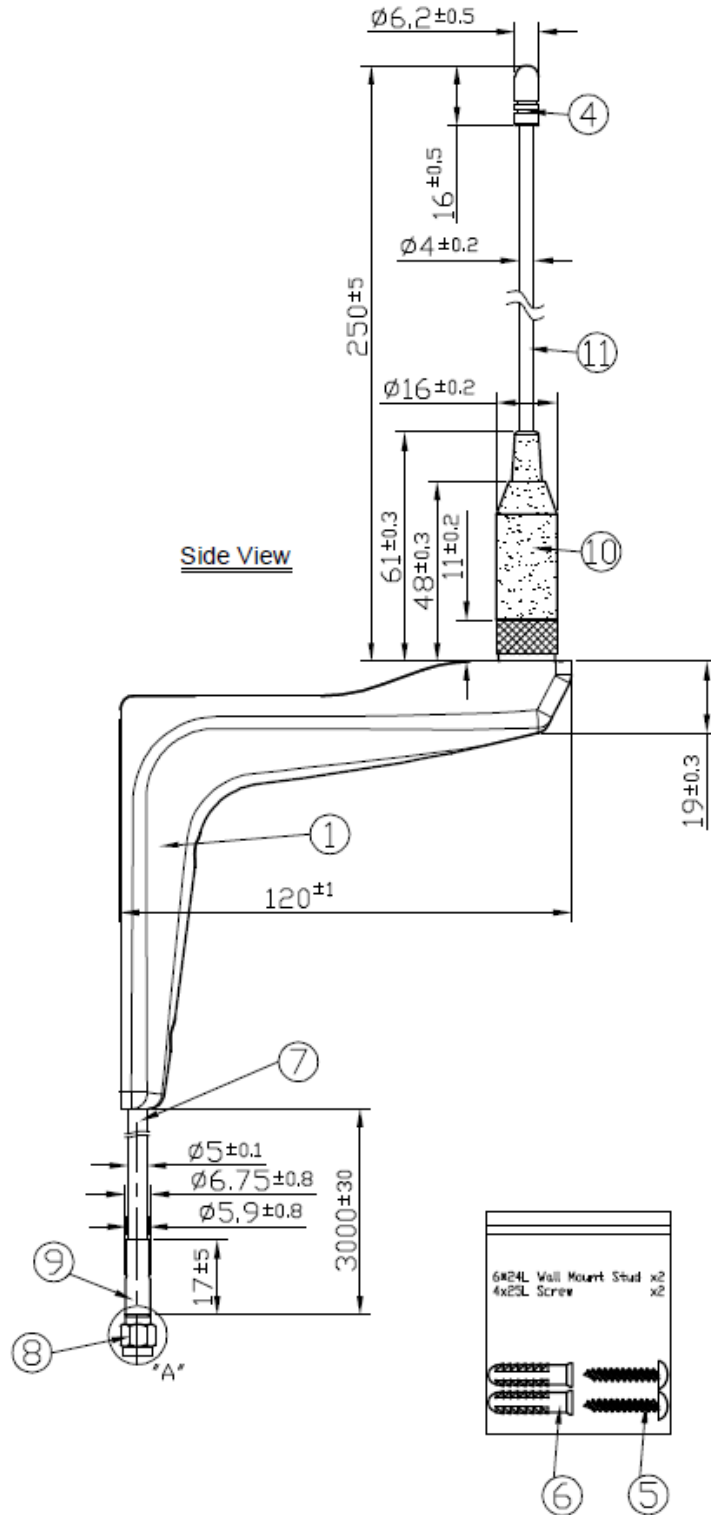



6. Packaging

Package:

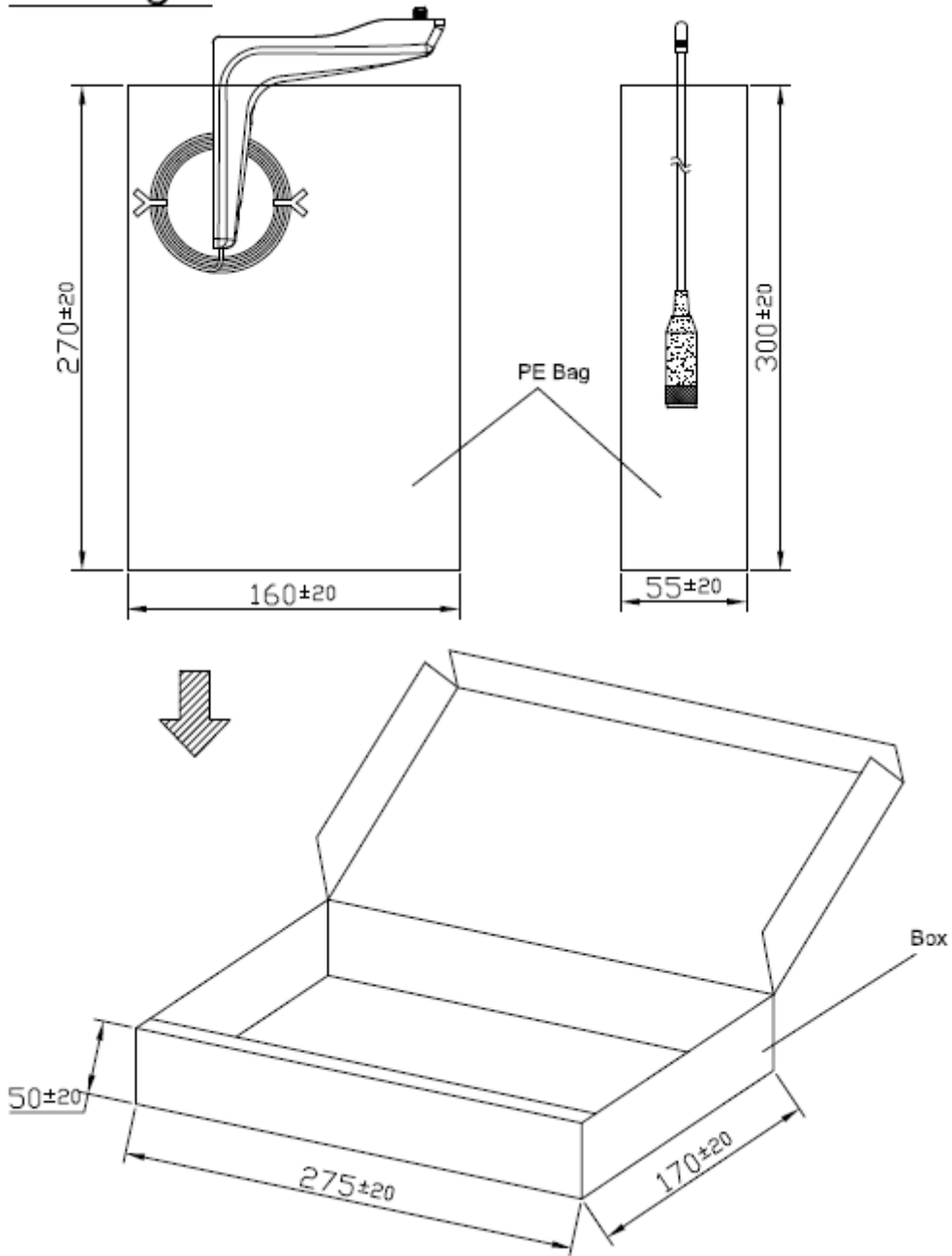

Unit:mm