

GEN. ST.	01	02	03	04	05	06	07	08	0D	50	60	70	80	90																	
INT. ST.	10	11	12	13	14	18	20	31	32	33	34	38	39	40	42	43	44	45	46	48	56	70	72	73	75	76	81	82	83	84	88

REV.	DATE	DESCRIPTION	BY	C'K'D'
A	2001-09-14	CONVERSION REVISION 03	KN	
B	2005-10-26	105-0205	ALEX B	BKP
C	2006-08-08	106-0144	ALEX B	BKP

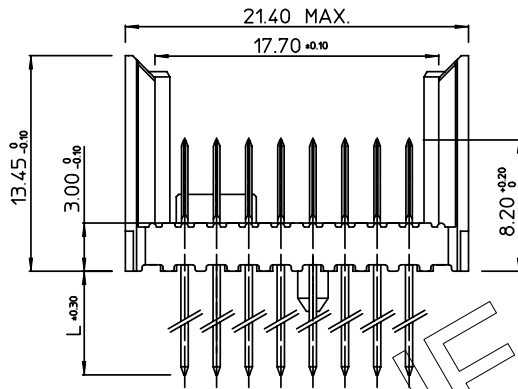
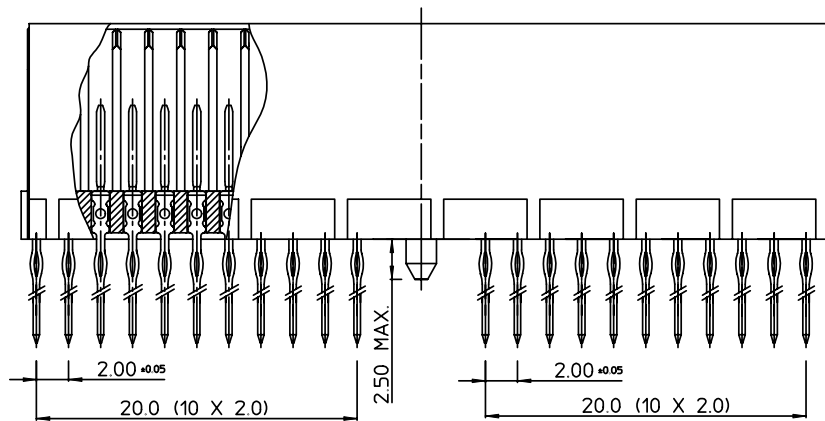

PERFORMANCE CHARACTERISTICS

CURRENT RATING : 1.5 A AT 20°C ( FULLY LOADED )  
 1 A AT 70°C ( FULLY LOADED )  
 RATED VOLTAGE : 500 V AC (CONT / CONT )  
 OPERATING TEMPERATURE : -55°C TO 125°C  
 CONTACT RESISTANCE : 20 mΩ MAX  
 INSERTION FORCE : 0.60 N MAX / CONT  
 EXTRACTION FORCE : 0.15 N MIN / CONT  
 INSULATION RESISTANCE : 10<sup>4</sup> MΩ MIN

CAT. NR.	L ±0.3	DESCRIPTION
HM2P87PD8110----	3.7	SHORT PRESS-FIT
HM2P87PC8110----	4.5	SHORT PRESS-FIT
HM2P87PK8110----	13	REAR PLUG-UP: LEVEL 1
HM2P87PM8110----	14.5	REAR PLUG-UP: LEVEL 2
HM2P87PN8110----	16	REAR PLUG-UP: LEVEL 3
HM2P87PT8110----	13	WIRE WRAP

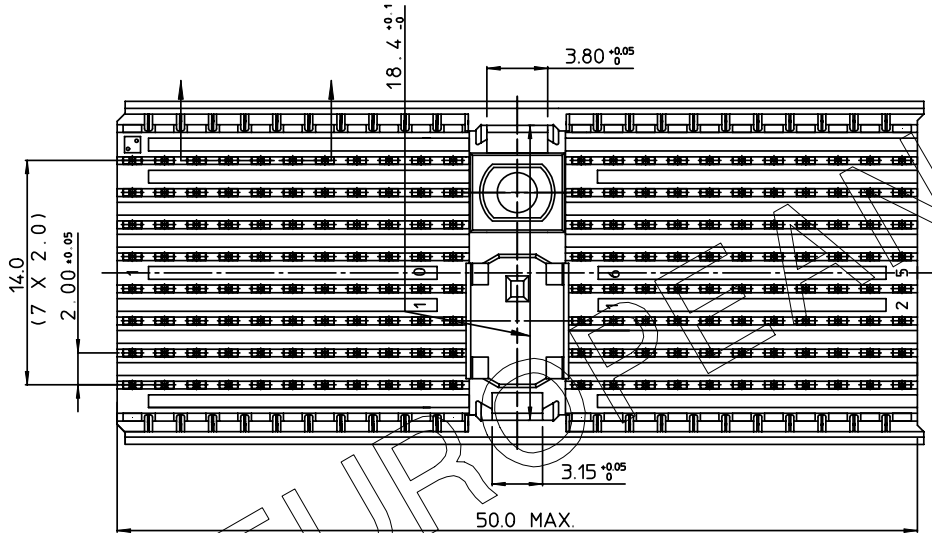

NOTES

- \*HM2P87P#8110<sup>1</sup> ← PERFORMANCE LEVEL INDICATOR (REFER DWG No. BS,C ,201844,003)  
 LEAD FREE INDICATOR : LF=LEAD FREE (DIGIT 15&16)
- THIS PRODUCT IS CSA APPROVED.  
 THIS PRODUCT IS UL RECOGNIZED.
- FOR RECOMMENDED PTH DIMENSIONS REFER DRAWING : BS,A ,201572,001
- THE PRODUCT (LF) MEETS EUROPEAN UNION DIRECTIVES AND OTHER COUNTRY REGULATIONS AS DESCRIBED IN GS-22-008

LAY-OUT  
P.C.B. - HOLE

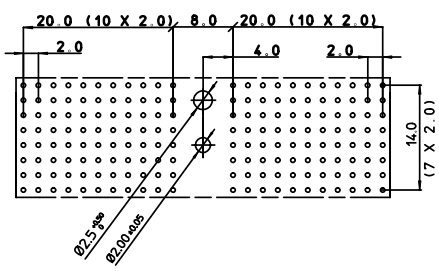

MALE SIGNAL STRAIGHT PRESS-FIT-TO-BOARD CONNECTOR WITH SERVICECENTER (WIDE BODY)

1DEC ±0.2 2DEC ±0.1 ANGLES ±1°	<b>APPR.</b>	<b>DATE</b>	<b>SIGN.</b>	MILLIPACS 2 / TYPE D (8 ROW) / NO SHIELDING
	DRAFT	1996-04-29	W.Panis	<b>CAT. No.</b> HM2P87P#8110----
	CHECKED			
WE RESERVE THE RIGHT TO CHANGE DIMENSIONS OR REQUIREMENTS WITHOUT PRIOR NOTICE.	PROD. MGR.			www.fcjconnect.com
	PR. ENG. MGR.			
ALL DIMENSIONS IN MM	PR. MGT. MGR.			

REFERENCES

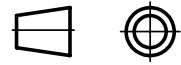

THIS IS OUR EXCLUSIVE PROPERTY. IT IS NOT TO BE COPIED, REPRINTED OR DISCLOSED TO A THIRD PARTY, NOR USED FOR MANUFACTURING WITHOUT OUR WRITTEN CONSENT, AND HAS TO BE RETURNED TO US IN CASE OF NO USAGE

DIT IS ONZE EIGENDOM EN MAG NOCH NAGEMAAKT, HERDRUKT, OVERGEMAAKT AN DEREN, NOCH VOOR FABRIKATIE GEBRUIKT WORDEN, ZONDER ONZE SCHRIFTELIJKE TOELATING. BIJ NIET GEBRUIK IS TERUGZENDING VERPLICHT.

PDM: Rev:C

STATUS: Released

CUSTOMER DRAWING REVISION  
Printed: Dec 02, 2007

# Mouser Electronics

Authorized Distributor

Click to View Pricing, Inventory, Delivery & Lifecycle Information:

[FCI / Amphenol:](#)

[HM2P87PD8110N9LF](#) [HM2P87PK8110GFLF](#)