

THIS DRAWING IS UNPUBLISHED. RELEASED FOR PUBLICATION
 © COPYRIGHT BY TYCO ELECTRONICS CORPORATION. ALL RIGHTS RESERVED.

LOC	DIST	REVISIONS					
GP	00	P	LTR	DESCRIPTION	DATE	DWN	APVD
		A		NEW RELEASE	6SEPT07	RG	PD

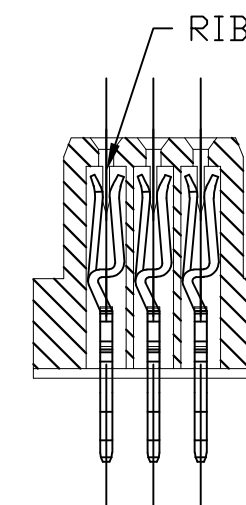
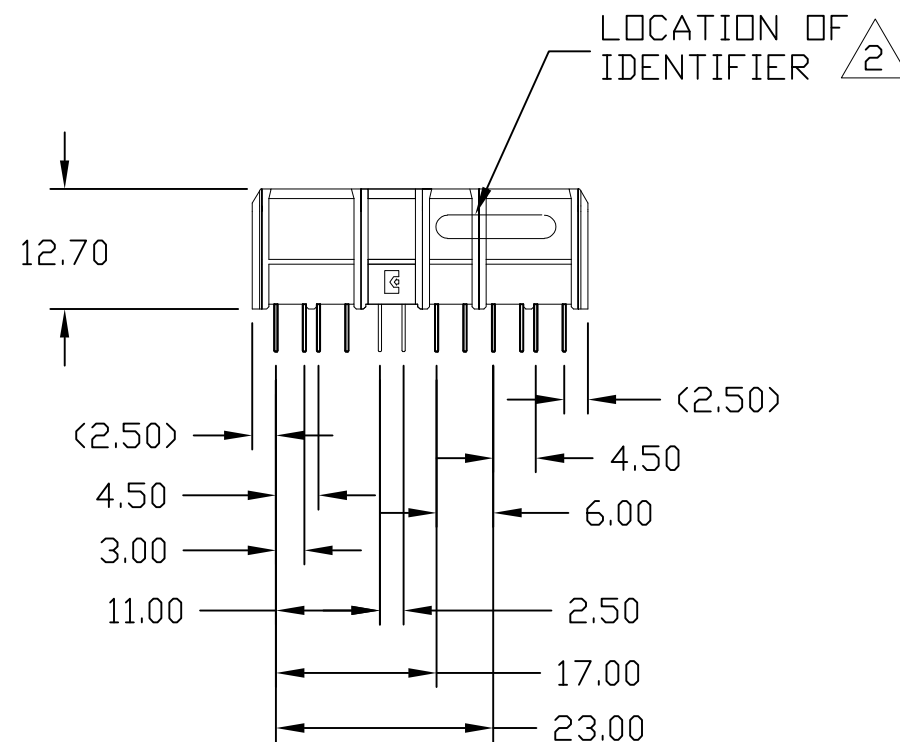
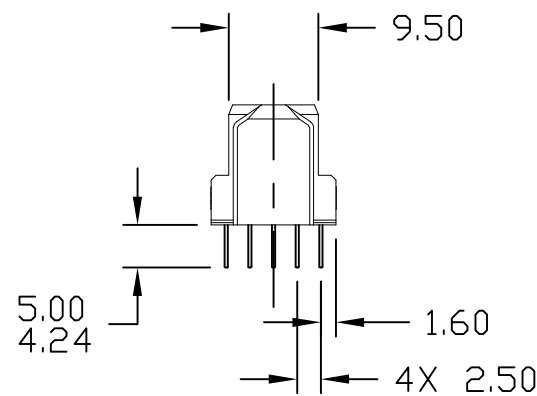
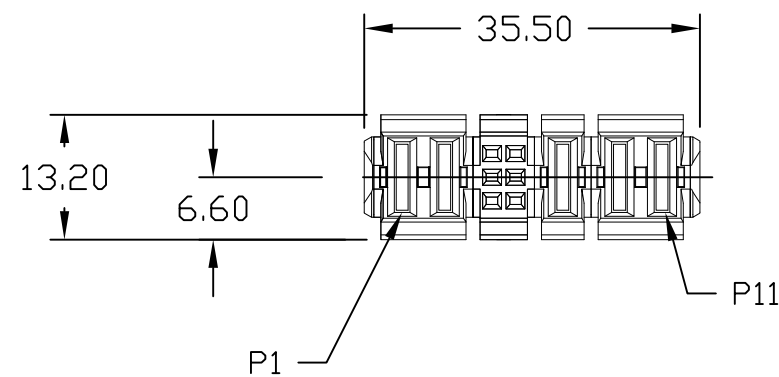

SECTION A-A
 SCALE: 2:1
 (POWER CROWNS OMITTED FOR CLARITY)

1. PART NUMBER CHANGES AND/OR DESIGN CHANGES AFFECTING ITEM INTERCHANGEABILITY REQUIRE PRIOR TYCO ELECTRONICS APPROVAL AND AUTHORIZATION BY REVISION TO THIS DRAWING.

2. ITEMS PROVIDED TO THIS SPECIFICATION TO BE PERMANENTLY IDENTIFIED PER THE FOLLOWING IDENTIFIER:



2. MATERIAL:
 INSULATOR: THERMOPLASTIC, GLASS REINFORCED, COLOR BLACK, UL 94V-0 FLAMMABILITY RATED
 CONTACT: COPPER ALLOY

3. FINISH:
 CONTACTS: GOLD PLATE 0,76µm MIN THK.
 OVER NICKEL 1,27µm MIN THK.
 SOLDER TAILS: TIN PLATE 3,05µm MIN THK.
 OVER NICKEL 1,27µm MIN THK.

AS SHOWN	6651609-1
DESCRIPTION	PART NUMBER

THIS DRAWING IS A CONTROLLED DOCUMENT.		DWN	06SEP2007	Tyco Electronics Corporation	
		CHK	6SEPT07	Harrisburg, PA 17105-3608	
		APVD	6SEPT07	NAME	
		P.DAMATO		SOCKET CONNECTOR, STRAIGHT	
		S.FLICKINGER		SOLDER TAILS	
		PRODUCT SPEC		MINIPAK	
		APPLICATION SPEC		SIZE	RESTRICTED TO
		WEIGHT		A3	—
		CUSTOMER DRAWING		CAGE CODE	DRAWING NO
				00779	6651609
				SCALE	SHEET
				1:1	1 OF 1
				REV	A

ELCON MINIPAK

Mouser Electronics

Authorized Distributor

Click to View Pricing, Inventory, Delivery & Lifecycle Information:

[TE Connectivity:](#)

[6651609-1](#)